

Condenser Microphones

and Microphone Preamplifiers
for acoustic measurements

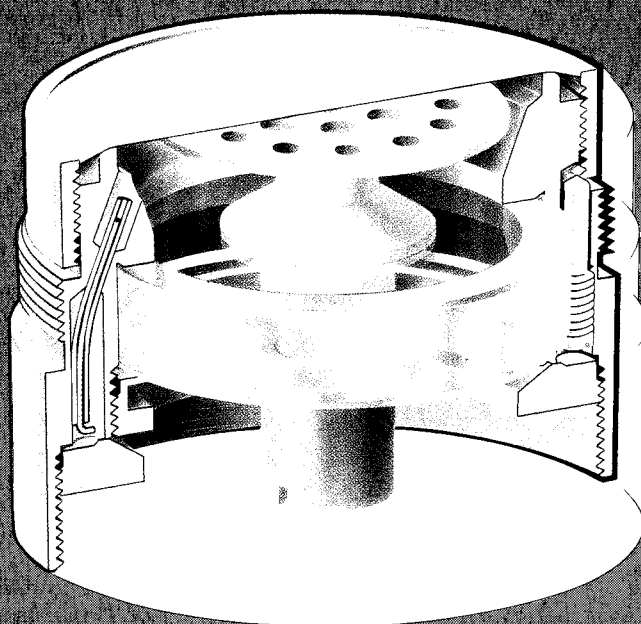

Data Handbook

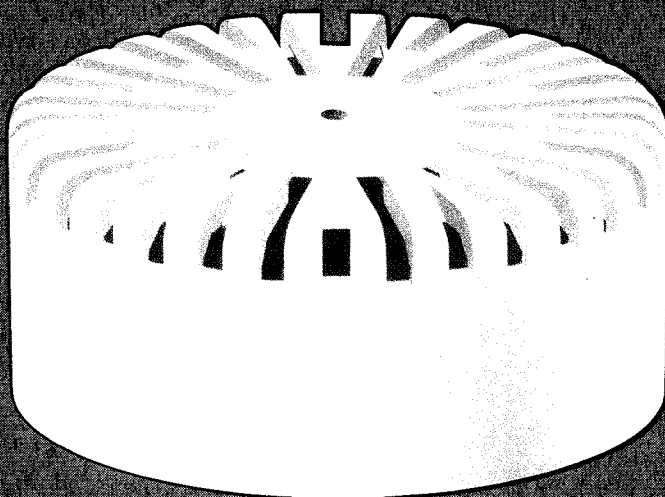
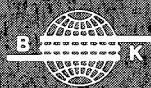

Brüel & Kjær

CONDENSER MICROPHONE CARTRIDGES

One-inch Types 4144, 4145

Half-inch Types 4133, 4134, 4147, 4148, 4149, 4165, 4166

Quarter-inch Types 4135, 4136

Eighth-inch Type 4138

MICROPHONE PREAMPLIFIERS

One-inch Type 2627

Half-inch Type 2619

Quarter-inch Type 2633

CONTENTS

1. INTRODUCTION AND SPECIFICATIONS (PRODUCT DATA)	1
1.1. CONDENSER MICROPHONE CARTRIDGES	1
1.2. MICROPHONE PREAMPLIFIERS	17
2. THE CONDENSER MICROPHONE AND ITS PREAMPLIFIER	25
2.1. PRINCIPLE OF OPERATION	25
3. MICROPHONE AND PREAMPLIFIER SELECTION	28
3.1. MICROPHONE SELECTION	28
3.2. PREAMPLIFIER SELECTION	30
3.3. MICROPHONE POWER SUPPLIES	32
4. OPERATION	33
4.1. PRELIMINARY CONSIDERATIONS	33
4.2. MOUNTING THE MICROPHONE AND PREAMPLIFIER	34
4.3. FIELD CALIBRATION	34
Pistonphone Type 4220	34
Sound Level Calibrator Type 4230	35
Measuring Amplifier Reference Voltage — Microphone K-Factor	35
Insert Voltage Calibration	37
Electrostatic Actuator	38
4.4. ACCESSORIES	38
5. CONSTRUCTION	39
5.1. PRINCIPLE	39
5.2. DIMENSIONS	41
5.3. PRESSURE EQUALIZATION ARRANGEMENTS	42
5.4. OUTDOOR MICROPHONE TYPE 4149	43
6. CHARACTERISTICS	44
6.1. SENSITIVITY	44
Open Circuit Sensitivity	44
Loaded Sensitivity	44

6.2.	FREQUENCY RESPONSE	45
	Microphone Calibration Chart	45
	High Frequency Response	45
	Free-Field Correction Curves to Electrostatic Actuator Response	46
	Pressure Response Microphones	55
	Free-Field Response Microphones	55
	Low Frequency Limit	56
	Frequency Response in a Helium Atmosphere	57
6.3.	DIRECTIONAL CHARACTERISTICS	58
6.4.	DYNAMIC RANGE	64
6.5.	PHASE CHARACTERISTICS AND PULSE RESPONSE	70
6.6.	EQUIVALENT VOLUME	73
6.7.	CAPACITANCE	76
6.8.	POLARIZATION VOLTAGE	78
6.9.	LEAKAGE RESISTANCE	82
6.10.	LONG-TERM STABILITY	83
6.11.	EFFECT OF TEMPERATURE	83
6.12.	EFFECT OF AMBIENT PRESSURE	87
6.13.	EFFECT OF HUMIDITY	92
6.14.	EFFECT OF VIBRATION	93
6.15.	EFFECT OF MAGNETIC FIELDS	93
6.16.	EFFECT OF SOLAR RADIATION	94
7.	CALIBRATION	95
7.1.	GENERAL	95
7.2.	RECIPROCITY CALIBRATION	95
7.3.	ELECTROSTATIC ACTUATOR	95
7.4.	HIGH PRESSURE CALIBRATION	97
7.5.	FACTORY CALIBRATION	97
	Sensitivity	97
	Cartridge Capacitance	98
	Frequency Response	98
	Low Frequency Limit (—3 dB point)	98
	Measurement of Equivalent Volume	100
8.	PREAMPLIFIERS	102
8.1.	DESCRIPTIONS	102
	General	102
	Quarter-Inch Preamplifier Type 2633	103
	Half-Inch Preamplifier Type 2619	103
	One-Inch Insert Voltage Preamplifier Type 2627	104
8.2.	FREQUENCY RESPONSE	106
8.3.	NOISE	106
8.4.	DISTORTION	108
8.5.	PHASE RESPONSE	108
8.6.	EFFECT OF HUMIDITY	110
8.7.	EFFECT OF TEMPERATURE	110
8.8.	EFFECT OF SOUND FIELD	110
8.9.	EFFECT OF VIBRATION	111
8.10.	EFFECT OF MAGNETIC FIELDS	111

9. ACCESSORIES	113
9.1. INTRODUCTION	113
Accessories Providing Immunity from the Environment	113
Accessories for Achieving Special Characteristics	113
Adaptors and Cables	113
Calibration Equipment	114
9.2. WINDSCREENS	114
Permanent Outdoor Windscreen UA 0570	114
Foam Windscreens UA 0207 and UA 0237	119
9.3. RAIN COVER UA 0393	122
9.4. NOSE CONES UA 0355, UA 0385, UA 0386 AND UA 0387	124
9.5. TURBULENCE SCREEN UA 0436	136
9.6. RANDOM INCIDENCE CORRECTOR UA 0055	139
9.7. DEHUMIDIFIER UA 0308	140
9.8. PROBE MICROPHONES	141
Horn Coupled Probe Microphone Type 4170	141
 LITERATURE LIST	 143
 INDEX	 145

types 4133, 4134, 4135, 4136, 4138, 4144, 4145, 4147, 4148, 4149, 4160, 4165 and 4166

Condenser Microphone Cartridges

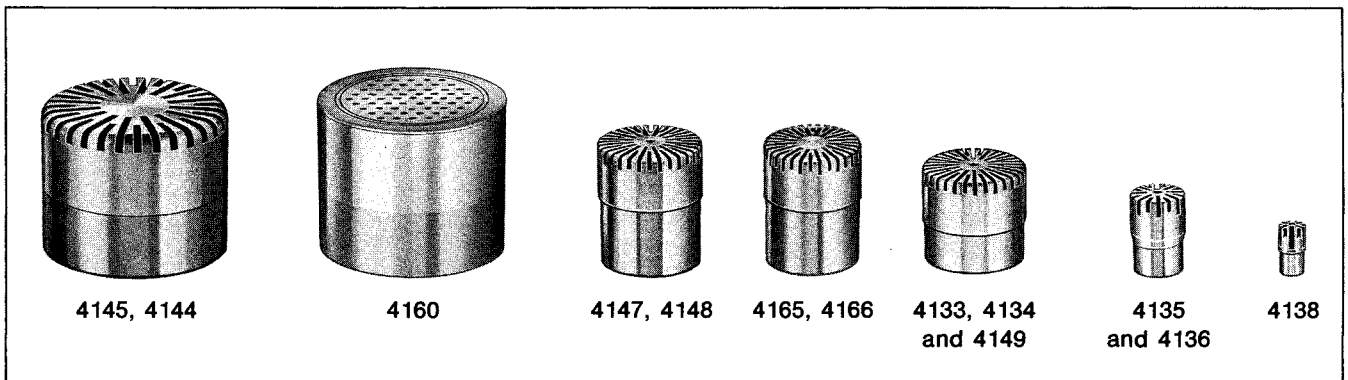

FEATURES:

- Frequency ranges from below 0,01 Hz to 140 kHz
- Dynamic ranges from -20 dB to 180 dB SPL
- Very wide temperature range
- High resistance to humidity
- Artificially aged for long term stability
- Flush mounted diaphragms
- Robust construction
- All operating characteristics well defined
- All important data individually calibrated and supplied
- Wide range of accessories

USES:

- Precision sound measurements
- Pressure variation measurements

The B & K measurement microphones are designed for accurate sound measuring purposes. They are precision engineered from materials selected to give long term stability. Their resistance to humidity is very high, the temperature range very wide and the temperature coefficients extremely small compared to other types of condenser microphones. A robust construction makes them easy to handle in the field. Each microphone is delivered in a protective mahogany box supplied with an individual calibration chart giving the frequency response and all data necessary for precision measurements (Fig. 1).

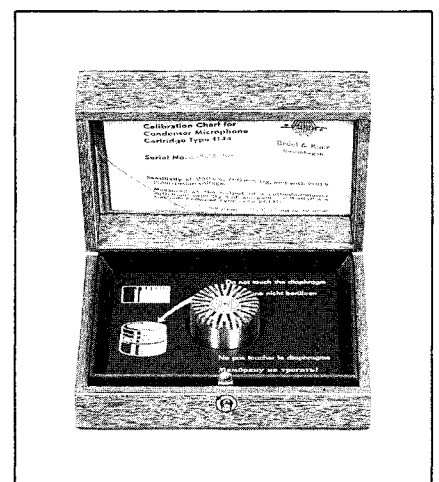

Fig. 1. 1" microphone cartridge in mahogany case with calibration chart

plied with an individual calibration chart giving the frequency response and all data necessary for precision measurements (Fig. 1).

General Description

Construction

The different cartridges have the same basic design (Figs. 2 and 3). The smaller diameters generally provide higher limits for the frequency and dynamic ranges, at the expense of a lower sensitivity.

Fig. 2 shows a sectional view of a condenser microphone cartridge. Depending on type, the insulator is made of either silicone-treated quartz, synthetic sapphire or a synthetic ruby to give dimensional stability. The diaphragm is made of pure nickel and backplate and housing are made of high nickel alloys. This minimizes variations of sensitivity with temperature.

During production the microphone cartridges are subjected to a high temperature (150°C), forced ageing process which ensures good long term stability.

Special care has been devoted to the equalization of the static air pressure between the inside and the outside of the cartridge to give a low and well defined lower limiting frequency.

The principles of the pressure equalization arrangements used in the cartridges are shown in Figs. 4 and 5. The Types 4147, 4148, 4149, 4160, 4165 and 4166 are back-vented for use with dehumidifiers, while all the other types are side-vented.

The cartridges are available with four different diameters:

1": 23,77 mm (Types 4144, 4145 and 4160)

1/2": 12,70 mm (Types 4133, 4134, 4147, 4148, 4149, 4165 and 4166)

1/4": 6,35 mm (Types 4135 and 4136)

1/8": 3,175 mm (Type 4138)

This wide range of condenser microphones is made available to cover an extensive field of applications. The microphones 4144, 4145, 4133, 4134, 4165, 4166, 4135, 4136 and

* Exactly 0,936 inch in accordance with the American Standard ANSI S1.12-1967.

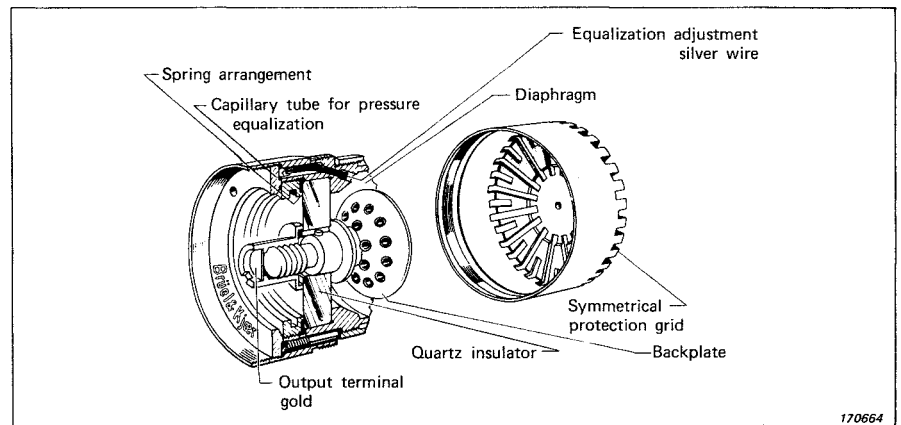

Fig. 2. Sectional view of a 1" condenser microphone cartridge

4138 together cover the requirements for environment, frequency and dynamic ranges for most sound measurements, while the special microphones 4147, 4148, 4149 and 4160 have been developed to suit particular applications.

Each size is available with either linear, 0° incidence, free-field frequency response or linear pressure response (the 1/8" Type 4138 pressure only). When using a free-field microphone it should be pointed towards the sound source, if the sound field is judged to come mainly from that direction. In some applications a pressure microphone may be used for free field measurements if arranged so that the diaphragm is parallel to the direction of sound. In coupler measurements a pressure microphone is used. In this case no specific orientation of the microphone in relation to the sound source is required. The smaller pressure microphones (1/2", 1/4" and 1/8" types) can be used for random incidence measurements at audio frequencies, as their frequency responses in this range are less dependent on angle of incidence. The 1" free-field microphone Type 4145 can also be used for random measurements in the audio range, when fitted with Random Incidence Corrector UA 0055.

A low cost microphone, Type 4130 is also available. The 4130 is a 1/2" condenser microphone cartridge for use with the self-contained microphone system consisting of the 1/2" Microphone Pre-amplifier Type 2642 and the battery operated Two-channel Microphone Power Supply Type

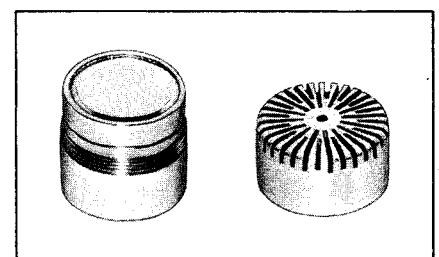

Fig. 3. 1" cartridge with protection grid removed. The diaphragm is flat and practically flush with the housing. This ensures a well defined acoustic impedance and excellent omnidirectivity

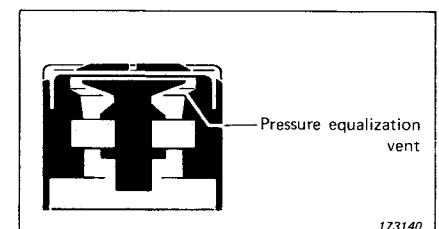

Fig. 4. Side-vented microphone cartridge

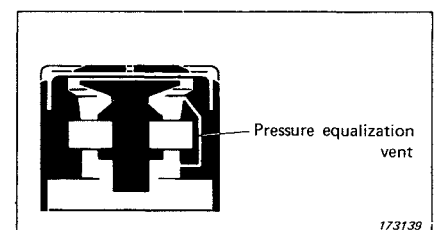

Fig. 5. Back-vented microphone cartridge

2810. The 2642 may also be used with other B & K 1/2" condenser microphones. For further information on Types 4130, 2642 and 2810, see separate Product Data sheets.

Three 1/2" Prepolarized Condenser Microphones Types 4129, 4155, and 4176, described in separate data sheets, are also available. Types 4129 and 4155 are acoustically similar to the Types 4130 and 4165 respectively, while Type 4176 is used with Precision Sound Level Meter Type 2232 (IEC 651, Type 1) and Integrating Sound Level Meters Types 2221 and 2222 (IEC Draft Proposal for Integrating Sound Level Meters, Type 1P).

In the following section a short description of characteristics and application ranges of each microphone is given.

General Purpose Types

Free Field Response Types

4145. 1" diameter for general laboratory use and very low sound level measurements.

4133. 1/2" diameter for general electroacoustic purposes, loudspeaker and microphone measurements.

4165. 1/2" diameter for general and low level sound measurements, and for standardized noise measurements according to IEC and ISO standards. It has a sensitivity similar to that of a 1" cartridge and may therefore be used as a substitute for 1" cartridges in applications where these would introduce an intolerable disturbance in the sound field being measured. The 4165 has a quartz covered diaphragm and is backvented for use with the 1/2" Dehumidifier UA 0308 for measurements in humid environments.

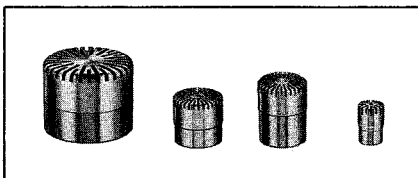

Fig. 6. Types 4145, 4133, 4165 and 4135

4135. 1/4" diameter for general high level, high frequency measurements and model work.

Pressure Response Types

4144. 1" diameter used for coupler measurements, audiometer calibra-

tion, low frequency and low level measurements, and as a laboratory standard.

4134. 1/2" diameter for medium and high level measurements in the audio range and coupler measurements.

Especially suitable where good random incidence characteristics are demanded.

4166. 1/2" diameter for random incidence measurements. Same application range as the 4165. The 4166 has also a quartz covered diaphragm and is backvented for use together with the UA 0308.

Especially suitable for noise measurements according to ANSI standards.

4136. 1/4" diameter for random incidence, coupler, high level and high frequency measurements.

4138. 1/8" diameter used for high level and very high frequency measurements, or for pulse measurements.

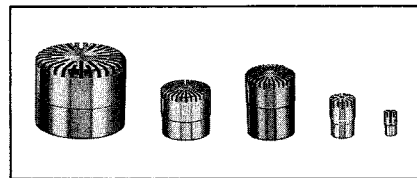

Fig. 7. Types 4144, 4134, 4166, 4136 and 4138

Especially suitable for applications which require a high spatial resolution of the sound field or where space is limited, e.g. model testing.

Special Types

Very Low Frequency Types

4147. 1/2" diameter. Pressure type designed with special attention to the back-venting pressure equalization arrangement to bring the lower limiting frequency below 0,01 Hz. It is used for ultra-low frequency acoustic pulses, e.g. sonic boom measurements in conjunction with Adaptor UA 0271 and Microphone Carrier System 2631.

Low Polarization Voltage Type

4148. 1/2" diameter. Free-field type used with 28 V polarization voltage for general sound level measurements with battery operated assemblies such as Preamplifier Type 2619 in conjunction with Power Supply Type 2804, or with Miniature Sound Level Meter Type 2206.

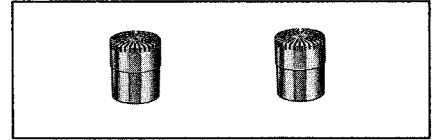

Fig. 8. Types 4147 and 4148

Type 4149, Protected for Outdoor Use

4149. 1/2" diameter. Free-field type, similar to 4133 but with diaphragm and backplate covered with thin layers of quartz (Fig. 9), which increases the lifetime in humid or corrosive atmospheres. It is back-vented for use with Dehumidifier UA 0308, (see section "Accessories"). The 4149 is used in noise monitoring systems such as the Type 4921, for permanent outdoor installations.

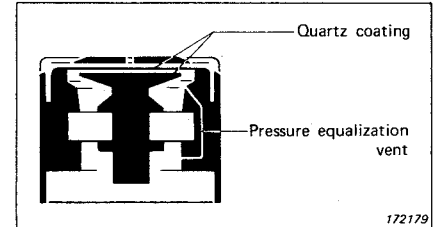

Fig. 9. Cross sectional view of the quartz-coated microphone Type 4149

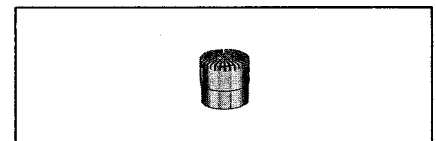

Fig. 10. Type 4149

Western Electric WE 640 A Equivalent

4160. 1" diameter. Pressure type for coupler measurements and as

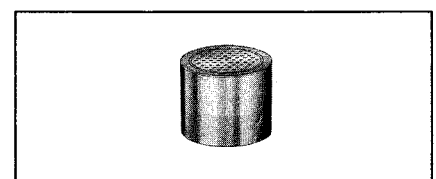

Fig. 11. Type 4160

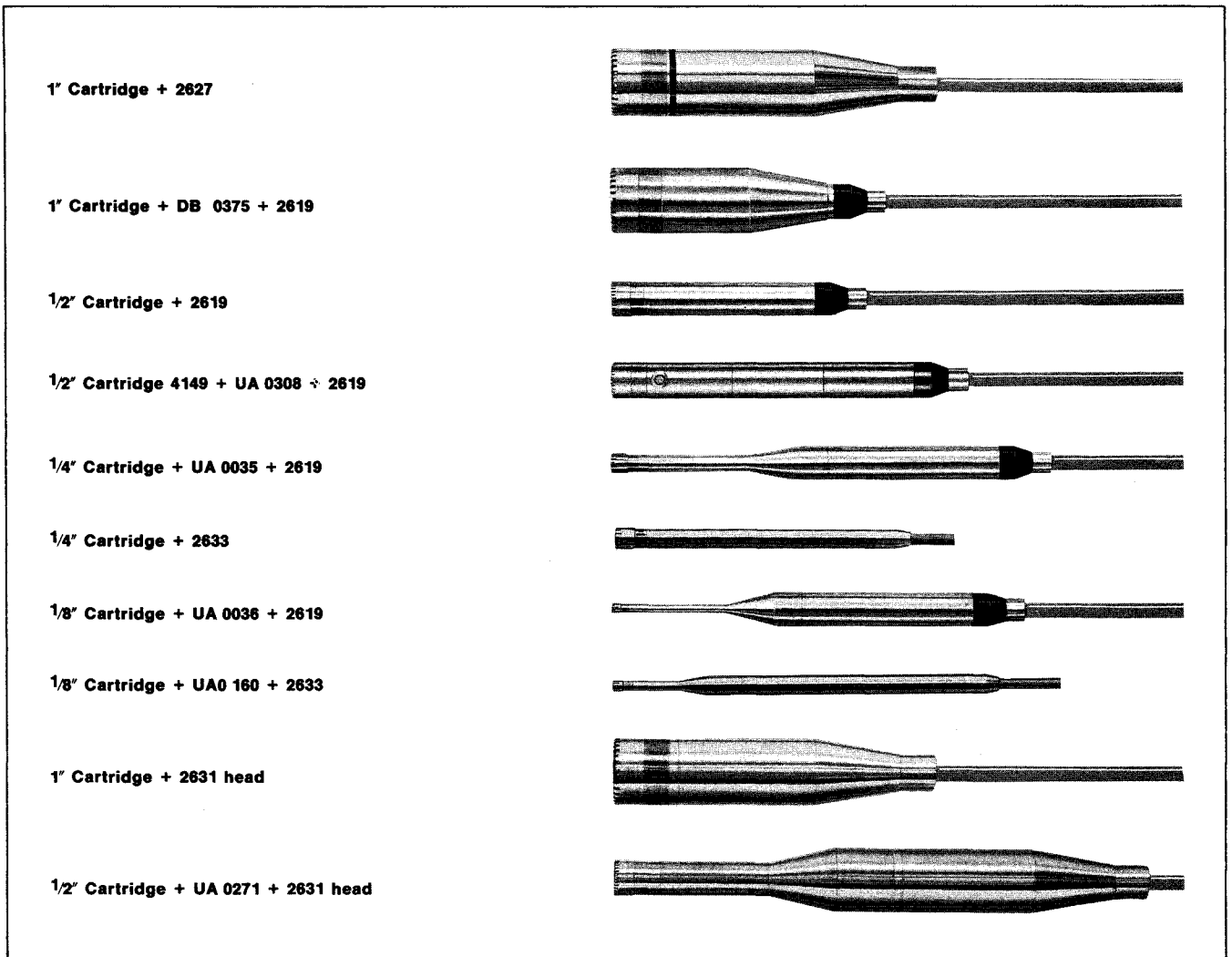
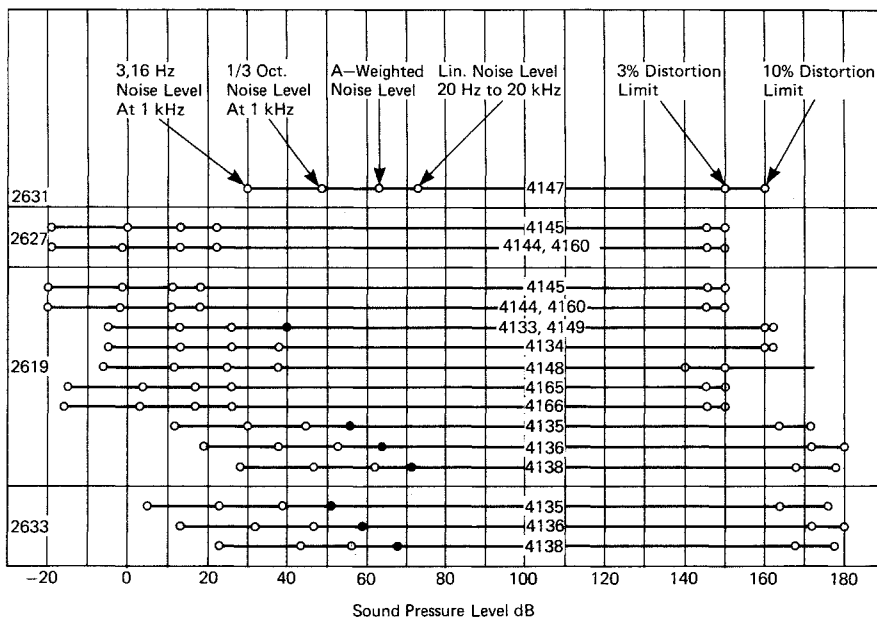

Fig. 12. Mounting the different microphones on the microphone preamplifiers and the carrier system head. Adaptor DB 0375 is included with the 2619 S, whereas other adaptors should be ordered separately



• Lin. 20 Hz to 200 kHz

820609

Fig. 13. Dynamic ranges of B & K Microphone Preamplifiers (except 2642) and the Carrier System 2631 with different microphones. The upper limit is indicated for two degrees of distortion while the lower limit is given for various bandwidths of the measuring equipment. The limits for 3,16 Hz and 1/3 octave bandwidth are valid at 1000 Hz only

laboratory standard. It has a linear pressure response and is equivalent to the Western Electric condenser microphone WE 640 A. The front cavity of the microphone is tested for hydrogen leakage. The 4160 is included with the Reciprocity Calibration Apparatus Type 4143.

Preamplifiers

The microphones are designed for use with a DC polarization voltage of 200 V (28 V for 4148) or with a 10 MHz carrier frequency. A microphone assembly will consist of a microphone cartridge and a preamplifier, when using the DC polarization voltage, and of the 10 MHz Carrier Frequency System Type 2631 and a cartridge when using the carrier frequency.

The cartridges screw directly onto the preamplifier housing or the 2631

head if both have the same diameter, or use is made of adaptors if the diameters differ (Fig. 12).

Three different preamplifiers are available. They all use a field effect transistor to achieve high input impedance and low inherent noise. Type 2619, 1/2" diameter is used directly with 1/2" microphone cartridges. To use 1", 1/4" and 1/8" cartridges with this preamplifier it must be fitted with the adaptors DB 0375, UA 0035 and UA 0036, respectively. The 2619 is available in two versions: 2619 S, with accessories and 2619 T without accessories. Type 2633, 1/4" diameter is used directly with 1/4" cartridges and with 1/8" cartridges via the adaptor UA 0160. Type 2627 is a 1" preamplifier with electrical insulation between the grounded housing of the preamplifier and the microphone cartridge. The 2627 is used primarily for calibration purposes.

Fig. 13 shows the dynamic ranges of the preamplifiers and the Carrier System Type 2631, when used with the different microphone cartridges.

For further details on the Preamplifiers see separate product data sheets (2619, 2627 and 2633; 4130, 2642 and 2810; and 2631).

Power Supply

The stabilized polarization voltage

for the cartridges (200 volt) and the power supply for the microphone preamplifier is available at the 7-pin preamplifier input socket of the B & K measuring amplifiers and frequency analyzers to which the microphone assemblies can be connected directly.

For operation with other equipment and for special applications the microphone assembly can be powered from the Power Supplies Types 2804 or 2807, the Eight Channel Multiplexer Type 2811 or use can be made of the Outdoor Microphone Unit Type 4921 or the Microphone Carrier System Type 2631. Further information can be found under "Accessories".

The condenser microphones described in this data sheet and pre-polarized Types 4129 and 4176 are also intended for use with the B & K Sound Level Meters, which supply the necessary polarization voltage (0 V for Types 4129 and 4176) and preamplification. Furthermore the Sound Level Meters contain a measuring amplifier with indicating instrument, weighting filters and an output amplifier for driving recording instruments such as Tape Recorders Types 7005 and 7006 and Level Recorders Types 2306, 2307 and 2309.

The Precision Sound Level Meters

Types 2210, 2215, and 2218 accept, with appropriate adaptors, the 1", 1/2" and 1/4" cartridges using 200 V DC polarization voltage. Type 4176 is intended for use with Precision Sound Level Meters Types 2211/22 and 2232. Type 4129 is used with Sound Level Meters 2225/26. For further details see Product Data sheets for 2210, 2215, 2218, 2221/22, 2225/26 and 2232.

Assembly Response

All data given in this leaflet are open circuit, which means that the cartridges have looked into an infinitely large impedance. In practice, however, the microphone cartridges are used together with a preamplifier which will influence the response of the total microphone assembly.

The size of the influence depends on the preamplifier input impedance, the capacitance of the microphone (and adaptor), the load by extension cables connected to the preamplifier and the attenuation of the preamplifier itself. The total response of the microphone assembly is found by adding the open circuit response to the response curves given in the data sheet for the preamplifiers.

For detailed information on the response of the microphone Type 4147 used with 10 MHz carrier frequency, see data sheet for Microphone Carrier System Type 2631.

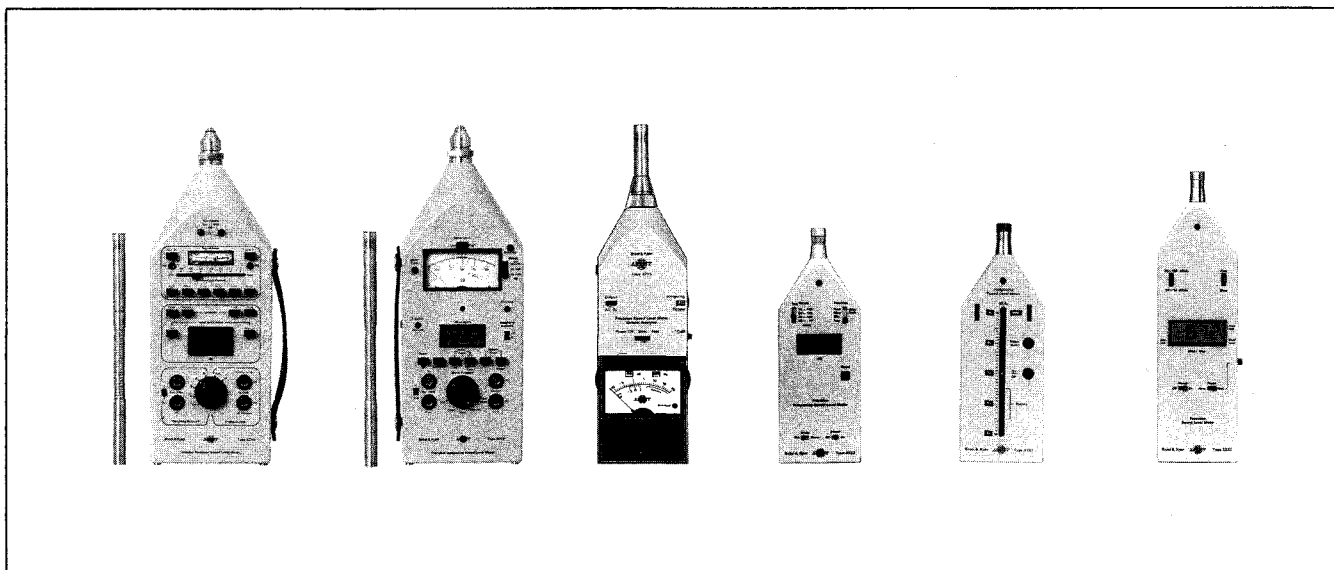

Fig. 14. Sound Level Meters Types 2210, 2218, 2215, 2221/22, 2225/26 and 2232

Cartridge Response

The microphone cartridges have well defined operating characteristics. Their sensitivities are high in relation to their dimensions and as can be seen from Figs. 15 and 16 their frequency ranges are very wide.

The long term stability is extremely good. The stability is of the order of 1 dB in several hundred years (see

specifications) while the same change appears in a few hours at 150 °C for all 1" and 1/2" microphones.

Individual Calibration

The microphones fulfil the American standard ANSI S1.12-1967 "Specifications for Laboratory Standard Microphones" as indicated in Table 1.

ANSI Type	B & K Type
XL	4144, 45, 47, 48, 33, 34, 49, 60, 65, 66
L	4144, 45, 60
M	4133, 34, 35, 36, 47, 49
H	4135, 36, 38

Table 1.

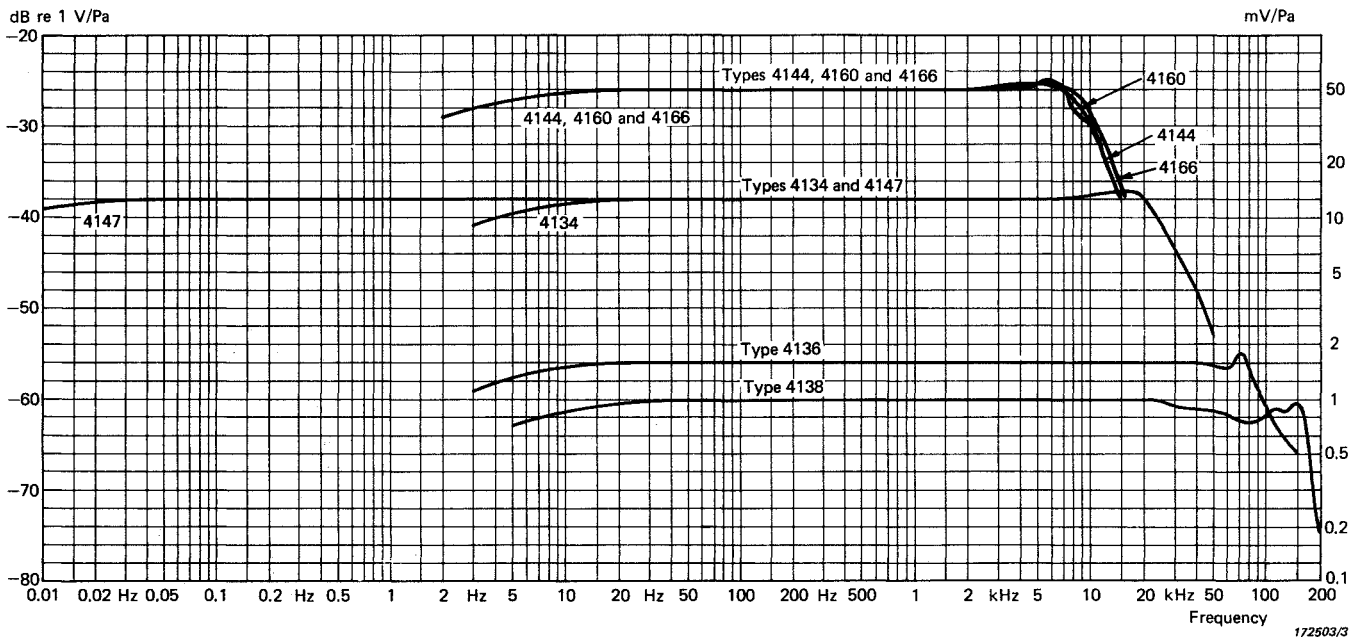

Fig. 15. Typical frequency responses of the different pressure microphones recorded by means of the electrostatic actuator method

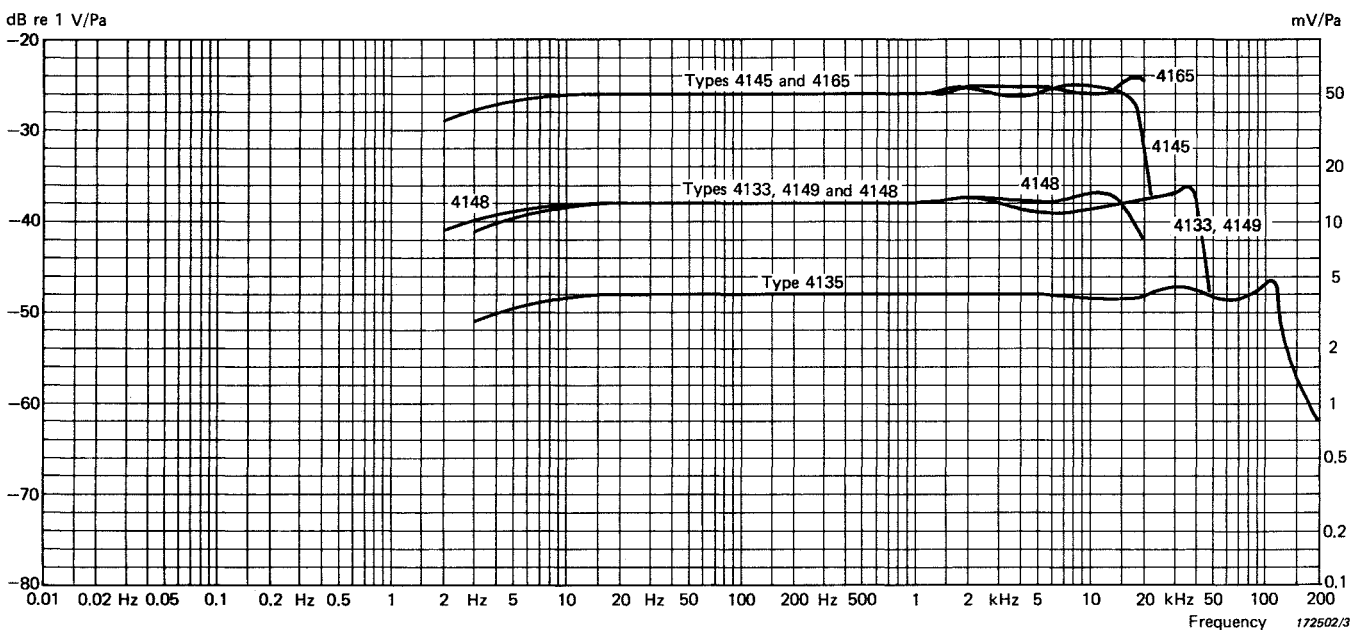

Fig. 16. Typical 0° incidence frequency response of the different free-field microphones recorded by means of the electrostatic actuator method and corrected according to the curves shown in Fig. 19

Each microphone cartridge is provided with an individual calibration chart including a complete frequency response curve recorded by the electrostatic actuator method. In the case of the free-field cartridges Types 4145, 4133, 4135, 4148, 4149, and 4165 the free-field response for 0° incidence is also given (see Fig. 18). This is derived by adding the free-field corrections to the recorded pressure response. Similarly, the diffuse-field response is individually determined for the cartridges 4134, 4135 and 4166.

The cartridge Type 4147 is additionally supplied with an individual calibration chart showing the time constant of the pressure equalization. From this chart the lower limiting frequency can easily be determined. See Fig. 17.

For the microphones, a comprehensive handbook is available describing, among other things, the design, the theory and the operation of each condenser microphone together with extensive documentation of its properties. Also described are the application of accessories and the influence of different environmental factors, such as temperature, atmospheric pressure, humidity etc. on the microphone.

Free-Field Corrections (to be added to the pressure response obtained from the calibration chart)

The free-field corrections which represent the increase of sound

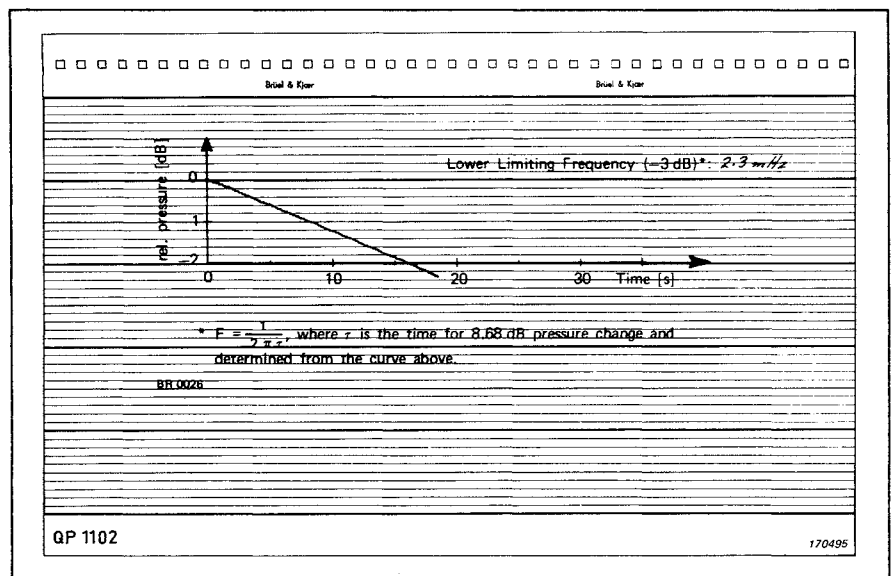

Fig. 17. Additional calibration chart delivered with the Condenser Microphone Cartridge Type 4147

pressure caused by diffraction of the sound waves around the microphone are only important at high frequencies where the wavelengths are comparable with the external dimensions of the microphone.

The free-field correction curves for diverse angles of incidence are given in Fig. 19. It can be seen that the random incidence (diffuse-field) corrections are very small at audio frequencies.

A microphone (1/2" to 1/8" diameter) with a flat pressure frequency char-

acteristic should consequently be preferred for measurements in diffuse-fields, for example for indoor measurements. However, by mounting specially designed correctors (Nose Cones) the response of the 1", 1/2" and 1/4" free-field microphones can be made practically independent of the angle of incidence over an extended frequency range.

A detailed description of the characteristics and specifications of the microphones will be found in the handbook available.

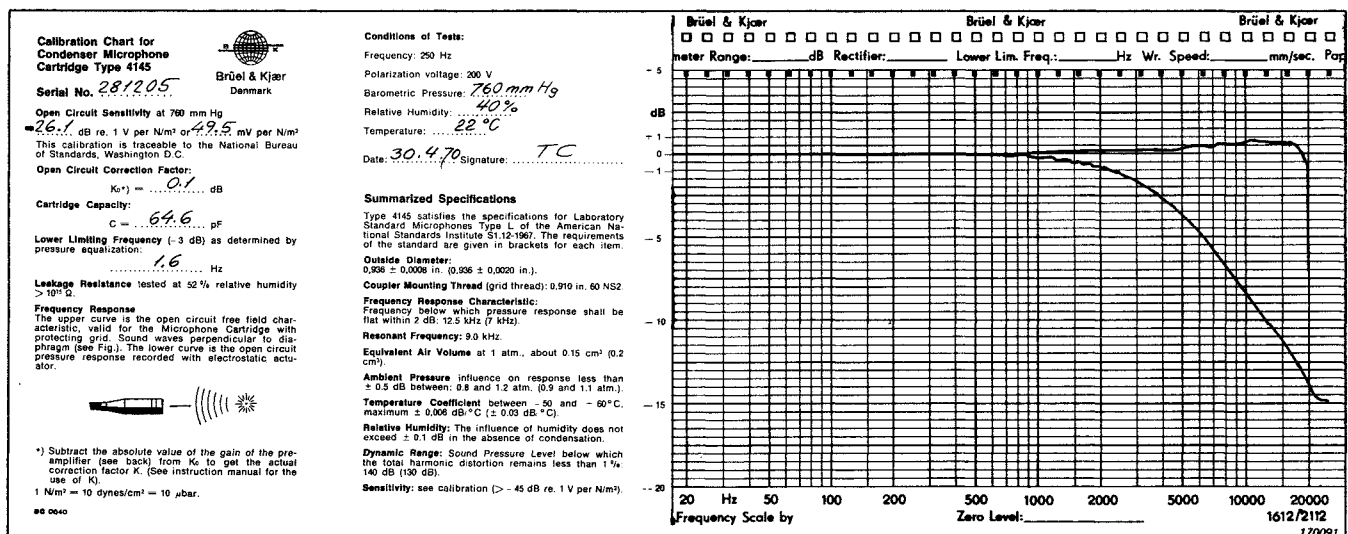

Fig. 18. Complete calibration chart delivered with the condenser microphone cartridges

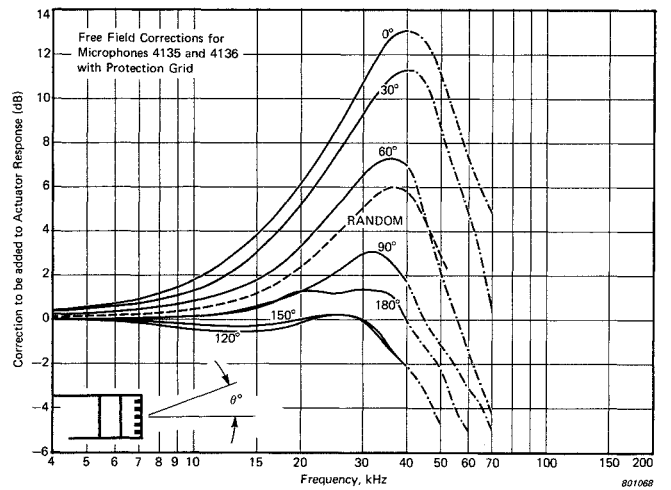
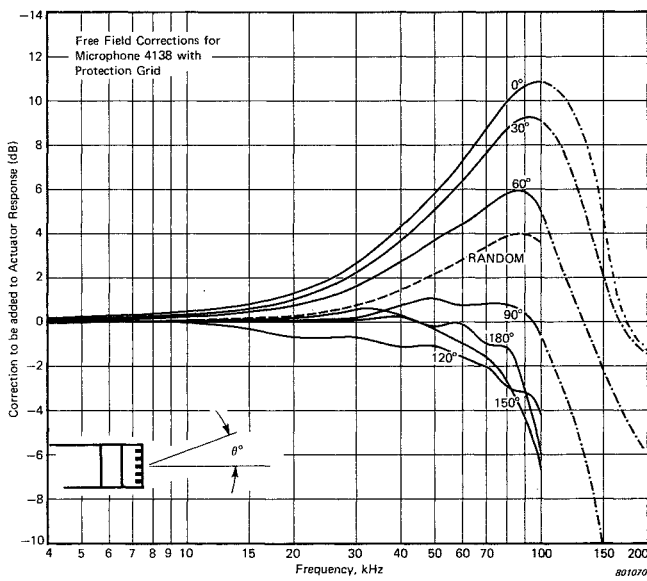
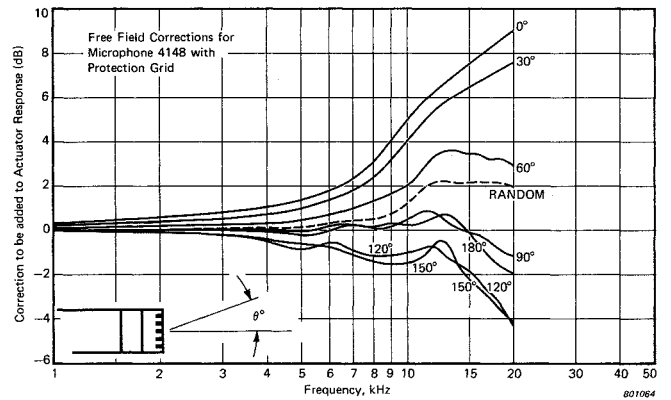
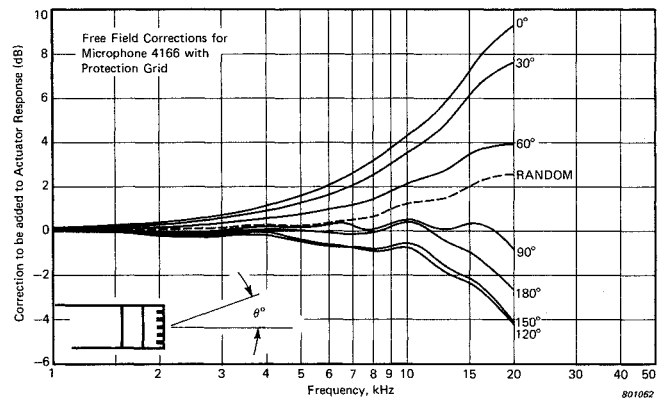
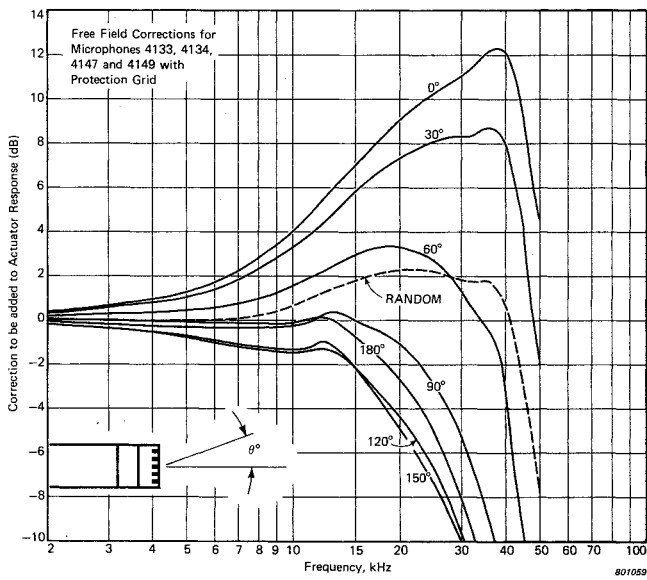
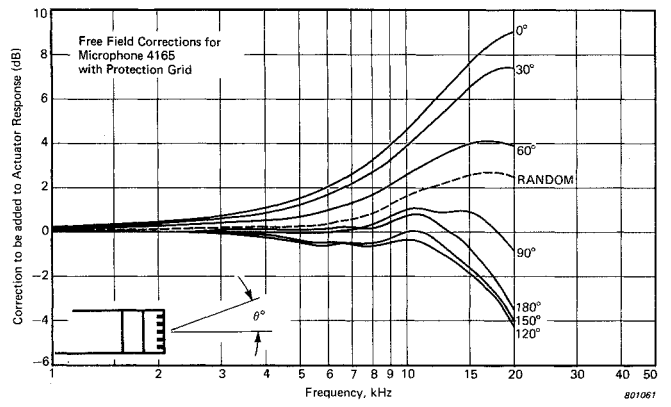
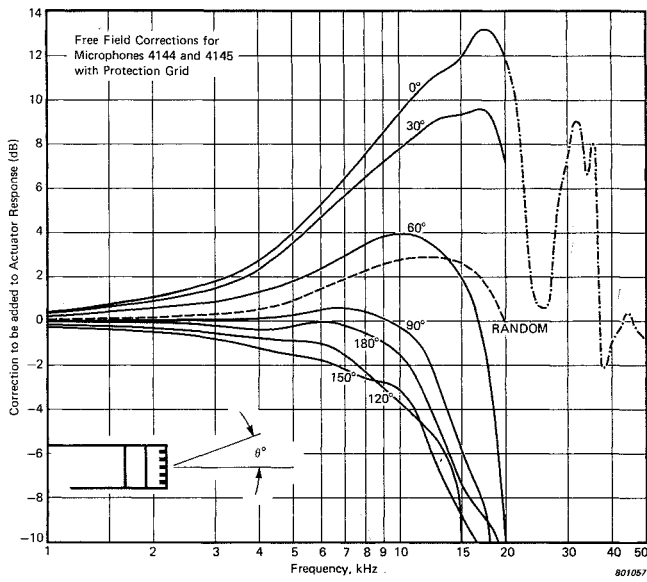

Fig. 19. Free-field correction curves for the various B & K condenser microphone cartridges

Accessories

To facilitate sound measurements under various conditions a variety of accessory equipment has been developed. A short description of these accessories is given in this section. For further information please see separate leaflets and the handbook available with the microphones.

Calibration Equipment 4220, 4230, 4143, 2627 and 4221

For accurate calibration of the microphones and complete sound measuring set-ups either in the laboratory or in the field, the Pistonphone Type 4220 or the Sound Level Calibrator Type 4230 can be used (Fig. 20). Both are battery operated and easy to handle. The 4220 gives a signal of 124 dB at 250 Hz and calibrates with an accuracy of $\pm 0,15$ dB. The Sound Level Calibrator Type 4230 gives a signal of 94 dB at 1000 Hz and calibrates with an accuracy of $\pm 0,3$ dB.

For laboratory calibration of standard microphones in accordance with IEC R 327 and IEC R 402 (reciprocity method) and for measurement of the frequency response of 1", 1/2", 1/4" and 1/8" condenser microphones by the electrostatic actuator method, the Reciprocity Calibration Apparatus Type 4143 is available (see Fig. 21). It is an advanced, fast and easily operated high precision laboratory instrument. The 4143 can also be used for comparison calibration of 1" and 1/2" microphones, mea-

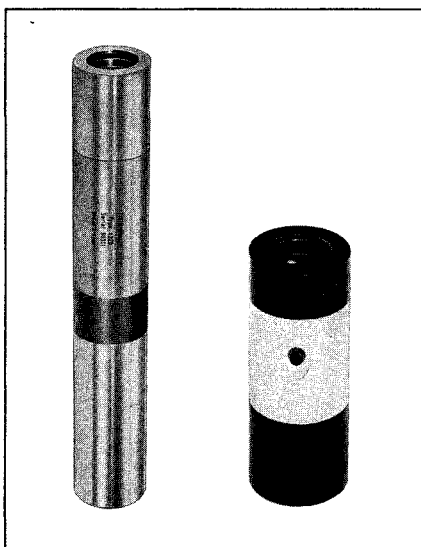

Fig. 20. Pistonphone Type 4220 and Sound Level Calibrator Type 4230

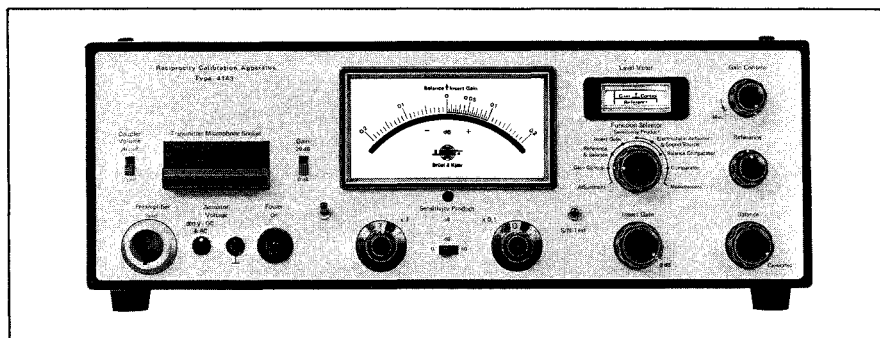

Fig. 21. Reciprocity Calibration Apparatus Type 4143

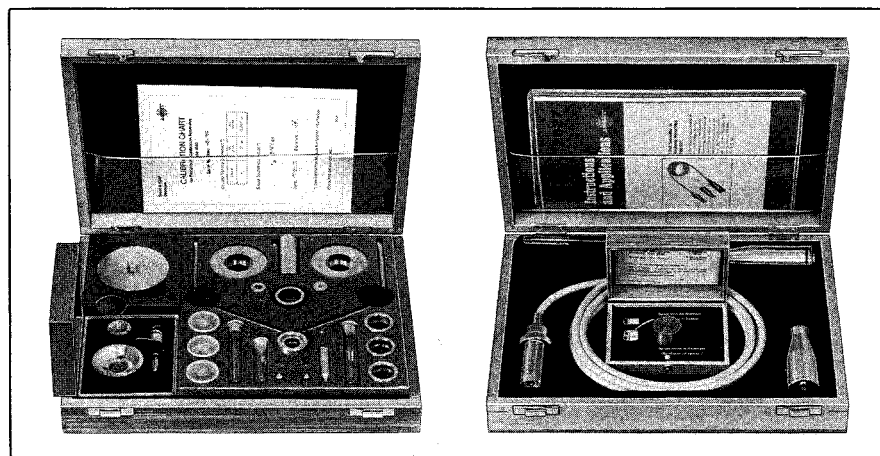

Fig. 22. Accessories delivered with the 4143

surement of front and equivalent volume, reciprocity and comparison calibration of accelerometers, reference sound source, ratio voltmeter and zero indicator. The 4143 is delivered with an individual calibration chart and a comprehensive range of accessories. See Fig. 22.

For calibration of 1", 1/2", 1/4" and 1/8" condenser microphones at high sound levels the High Pressure Microphone Calibrator Type 4221 is an ideal tool (Fig. 23). Due to the low acoustic impedance of the 4221 the sound pressure produced in the cou-

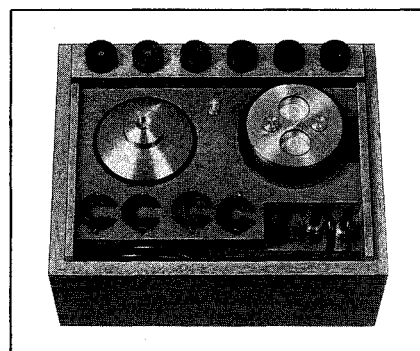

Fig. 23. High Pressure Microphone Calibrator Type 4221

plers is practically independent of variation in coupler volume, atmospheric pressure and changes in the process from adiabatic to isothermal at low frequencies. Calibration can be performed in the frequency ranges 3 Hz to 1000 Hz and 10^{-2} Hz to 95 Hz at SPLs up to 164 dB. In connection with tonebursts, supplied from the Gating System Type 4440, calibration up to 170 dB SPL can be performed.

Electrostatic Actuators UA 0023 and UA 0033

The actuators are designed for measurement of the pressure frequency response of the condenser microphone cartridges. They are available in two sizes UA 0023 for 1" microphones and UA 0033 for 1/2" microphones. The UA 0033 can also be used with 1/4" and 1/8" cartridges by means of the adaptors DB 0264 (1/4" to 1/2") and DB 0900 (1/8" to 1/2").

Electrostatic actuators not only enable laboratory frequency response calibration of microphones to high levels of accuracy but also allow users without extensive lab-

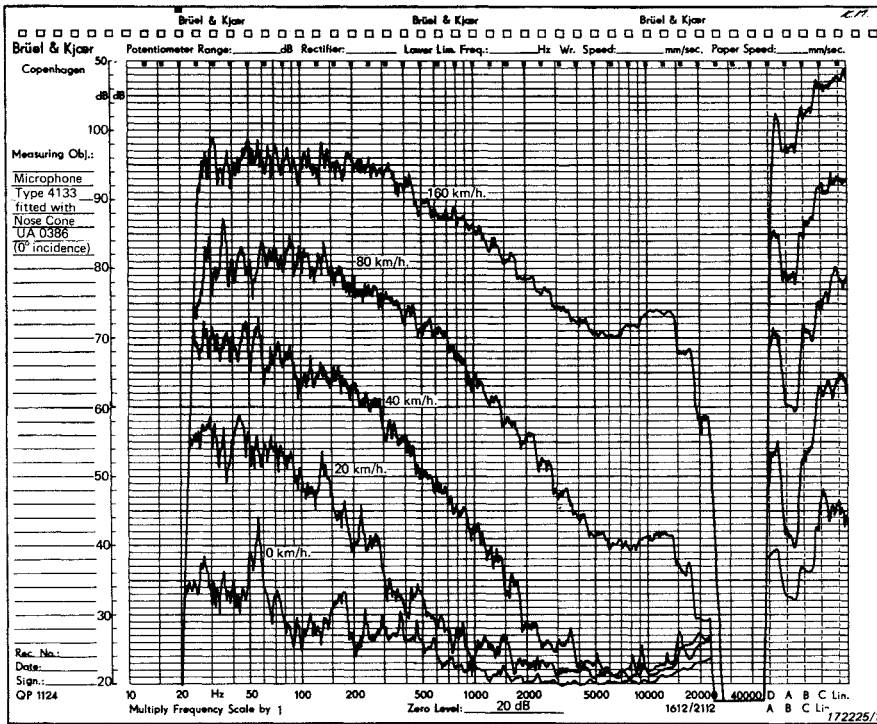

Fig. 24. Induced noise levels as a function of windspeed and frequency of the 1/2" free-field Condenser Microphone Cartridge Type 4133 fitted with Nose Cone UA 0386

oratory facilities to carry out periodic checks on the frequency response characteristics of their own microphones to ensure that they remain within acceptable limits.

Nose Cones UA 0387, UA 0386, UA 0385 and UA 0355

The Nose Cones (Fig. 28) are designed to reduce the aerodynamically induced noise present when the microphones are exposed to high wind speeds in a known direction, for example during sound measurements in wind tunnels, ducts, etc. They are designed to replace the normal protection grid of the microphones, and are of a streamlined shape with a highly polished surface in order to give the least possible air resistance. The fine wire mesh around the circumference allows sound waves to penetrate to the microphone diaphragm.

Fig. 24 shows the aerodynamically induced noise at various windspeeds in the microphone cartridge 4133 fitted with Nose Cone UA 0386. The diagram is valid for microphone 4149.

When the Nose Cones are used, the omnidirectional characteristics are improved (Figs. 25, 26, 27 and 30). Fig. 31 shows the omnidirectional characteristics of the 1/8" pressure cartridge fitted with Nose Cone UA 0355.

Random Incidence Corrector UA 0055

The UA 0055 (Fig. 29) screws directly onto the one inch microphone Type 4145 instead of the normal protection grid. It improves the microphone's omnidirectional characteristics so that IEC 651 Type 1 is fulfilled up to 10 kHz. See Fig. 32.

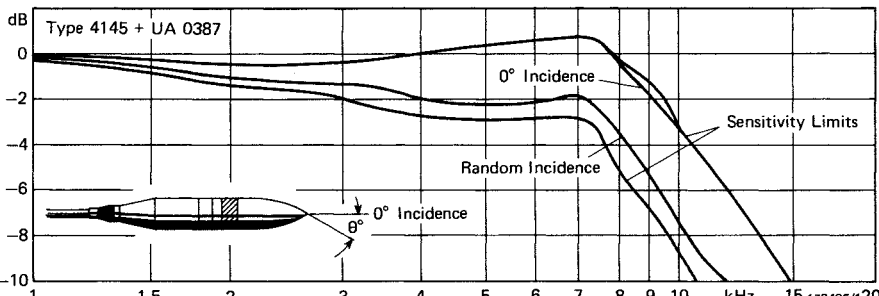

Fig. 25. Frequency response of the 1" free-field Condenser Microphone Cartridge Type 4145 fitted with Nose Cone UA 0387

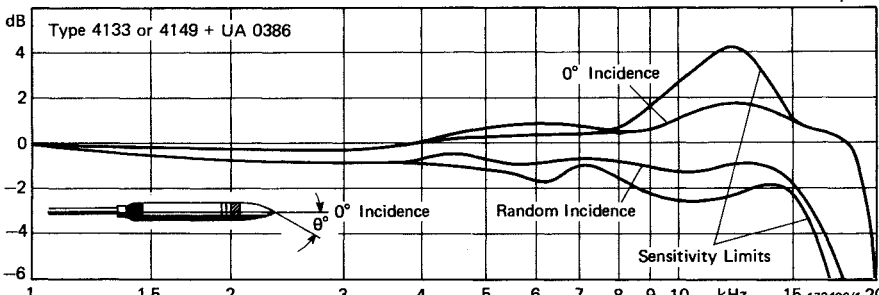

Fig. 26. Frequency response of the 1/2" free-field Condenser Microphone Cartridges Types 4133 and 4149 fitted with Nose Cone UA 0386

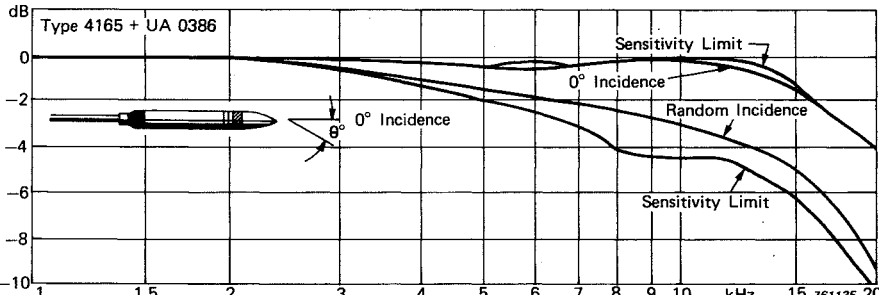

Fig. 27. Frequency response of the 1/2" free-field Condenser Microphone Cartridge Type 4165 fitted with Nose Cone UA 0386

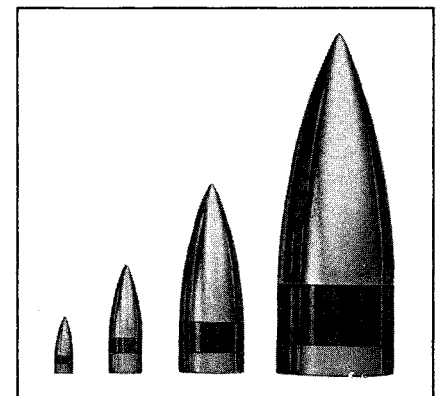

Fig. 28. Nose Cones UA 0355, UA 0385, UA 0386 and UA 0387

Rain Cover UA 0393

The Rain Cover (Fig. 29) is designed to be mounted on B & K 1/2" condenser microphones instead of the normal protection grid, and allows permanent outdoor installation even under adverse weather conditions. When fitted, the Rain Cover will improve the omnidirectional characteristics of the 1/2" free-field microphones (see Fig. 33). The combination of a 1/2" free-field cartridge, UA 0393 and Windscreen UA 0570 fulfils the requirements on directivity given in IEC 651 for Type 1 Sound Level Meters. To allow remote calibration and checking of remote microphone installations the UA 0393 has a built-in electrostatic actuator. The Rain Cover can be delivered calibrated at the factory together with a 1/2" microphone cartridge to give an equivalent SPL of 90 ± 1 dB by injection of an AC voltage of 215 V.

The B & K plugs JP 0012, which fit the actuator terminal are available in sets UA 0129, 20 plugs with mounting tool and UA 0130, 25 plugs only. The cable AC 0010 for plug JP 0012 is available in free length.

It is recommended that, whenever weather protection is important, the Permanent Outdoor Windscreen UA 0570 is always used in conjunction with the Rain Cover UA 0393, and that the Pre-amplifier heating element operates continuously.

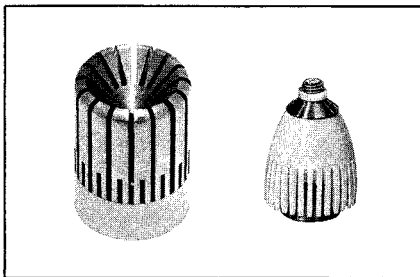

Fig. 29. Random Incidence Corrector UA 0055 and Rain Cover UA 0393

Permanent Outdoor Windscreen UA 0570

The Windscreen UA 0570 (Fig. 34) for 1/2" microphones, reduces the aerodynamically induced noise during outdoor sound measurements. The Windscreen is designed for mounting on the microphone assembly and gives an effective reduction, of the order of 10 dB or higher, of wind induced noise at lower wind ve-

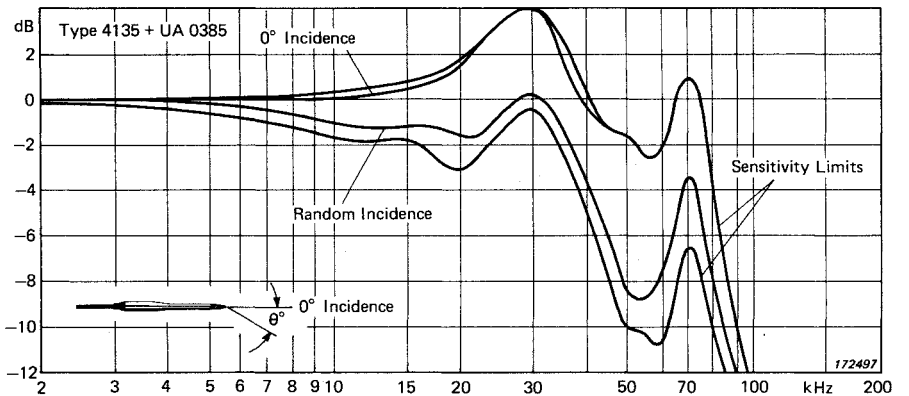

Fig. 30. Frequency response of the 1/4" free-field Condenser Microphone Cartridge Type 4135 fitted with Nose Cone UA 0385

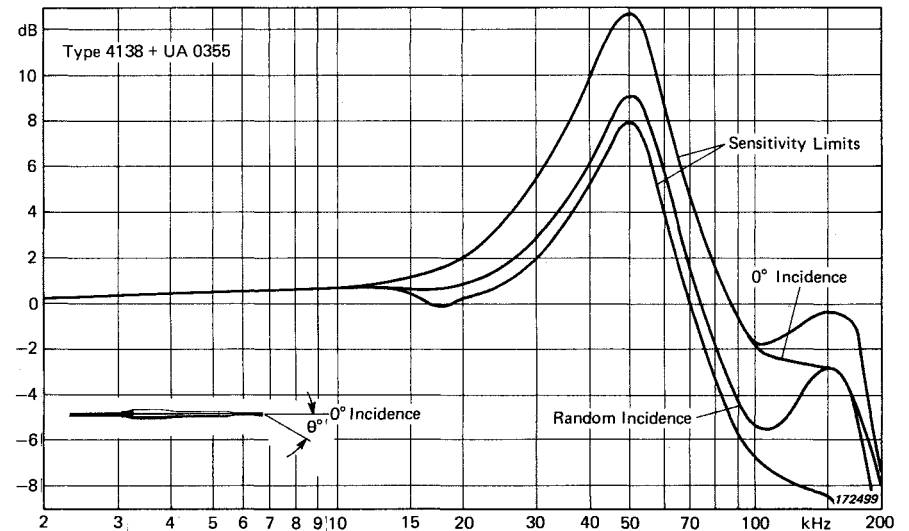

Fig. 31. Frequency response of the 1/8" pressure Condenser Microphone Cartridge Type 4138 fitted with Nose Cone UA 0355

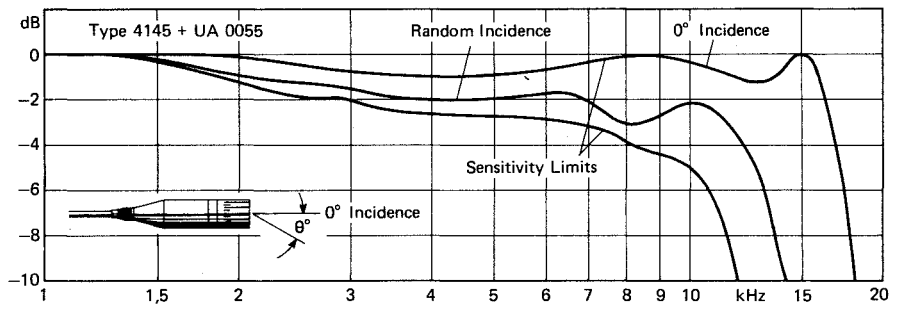

Fig. 32. Frequency response of the 1" free-field Condenser Microphone Cartridge Type 4145 fitted with Random Incidence Corrector UA 0055. The linearity is maintained practically up to 10 kHz, and the omnidirectivity is effective within ± 3 dB. (See also Fig. 19)

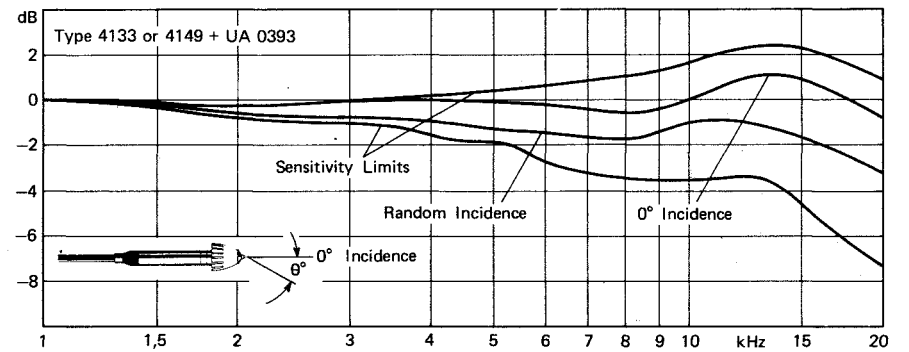

Fig. 33. Frequency response of the 1/2" free-field condenser Microphone Cartridges Types 4133 and 4149 fitted with Rain Cover UA 0393

locities. It is well suited to permanent outdoor installations in connection with Rain Cover UA 0393. Additionally, it is equipped with spikes to prevent birds from resting on top. The Windscreen is recommended for all unattended noise measurements.

Windscreens UA 0207, UA 0237 and UA 0459

The Windscreens UA 0207 and UA 0237 (Fig. 34) fit the 1" and 1/2" microphone assemblies respectively. They are made of specially prepared porous polyurethane sponge attenuating wind noise 10 to 12 dB, at lower wind velocities, and are well suited for hand-held outdoor sound measurements. These windscreens are only available as sets. **Set UA 0253** contains six 1" windscreens UA 0207, and **set UA 0254** contains six 1/2" windscreens UA 0237.

The Windscreen UA 0459, 65 mm diameter, is designed to fit the 1/2" Condenser Microphone Type 4130 but can also be used with the other 1/2" microphones if a small screen is required. The UA 0459 has approximately the same properties as the UA 0237. The windscreen is available in sets of six as **UA 0469**.

For complete curves showing the influence of any of the windscreens upon the free-field corrections see the handbook for the microphones.

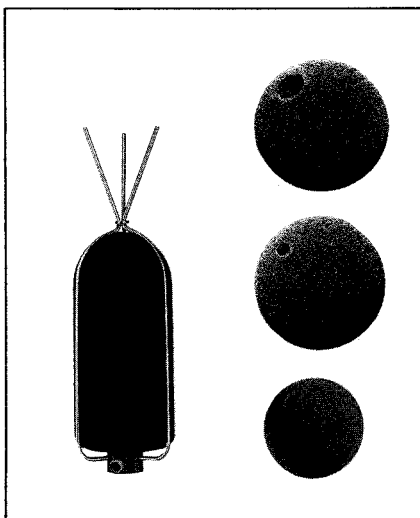

Fig. 34. Windscreens UA 0570, UA 0207, UA 0237 and UA 0459

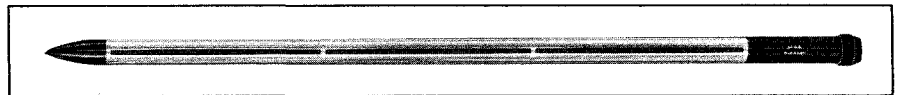

Fig. 35. Turbulence Screen UA 0436

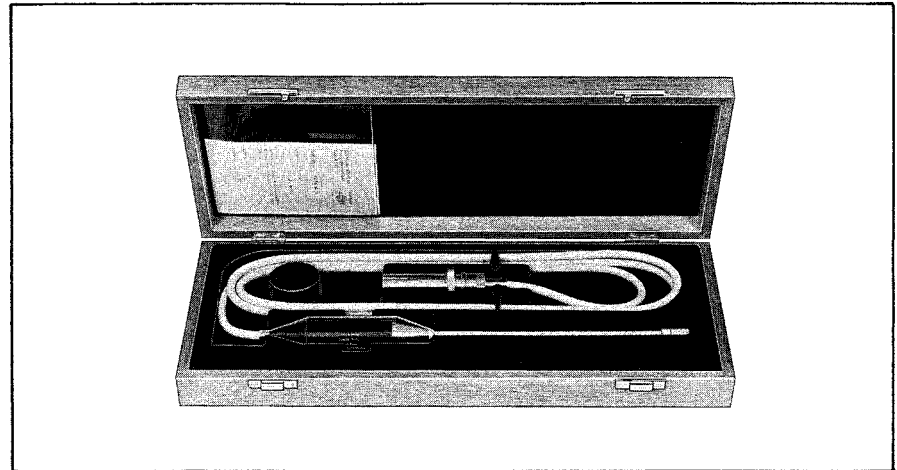

Fig. 36. Probe Microphone Type 4170

Turbulence Screen UA 0436

The Turbulence Screen UA 0436 (Fig. 35) is designed to attenuate turbulence noise, when measuring airborne noise in ducts, wind tunnels etc. The UA 0436 can be used together with any 1/2" free-field condenser microphone mounted on a 1/2" microphone preamplifier. The turbulence noise suppression obtained using the UA 0436 is approximately 16 dB better than that obtained with the Nose Cone UA 0386 in the frequency range 70 Hz to 1,5 kHz.

Probe Microphone Type 4170

Probe microphones can be used in a variety of applications, such as measurements inside the ear and inside ear protectors, measurements on sound insulating materials and inside intricate machinery, as well as in other confined spaces, e.g. small ducts, furnaces, oilburners etc.

Type 4170 (Fig. 36) is a pre-adjusted probe microphone with built-in preamplifier. It uses an acoustical exponential horn to couple a probe tube to a 1/2" condenser micro-

phone. An acoustic matching impedance at the microphone equalizes the frequency response of the assembly, thereby obtaining a frequency response from 30 Hz to 8 kHz within 3 dB. In order to obtain minimum disturbance in the sound field being measured the probe tube is very thin and has a high acoustic orifice impedance. The probe microphone is delivered with an individual calibration chart and an adaptor DP 0181 for fitting it to the Pistonphone Type 4220 or to the Calibrator Type 4230 for calibration.

Power Supplies 2804 and 2807

The Power Supply Type 2804 is battery driven and can be used with the Preamplifier Types 2619 and 2633. It supplies all necessary voltages for two microphone assemblies and can be adjusted to give 28 or 200 V polarization voltage. The Two Channel Power Supply Type 2807 can supply all voltages for two microphone assemblies using 200 V polarization voltage, and allows automatic switching between the measuring points, e.g. for sound insulation measurements.

Eight Channel Multiplexer Type 2811

For multichannel measurements, the Eight Channel Multiplexer Type 2811 (Fig. 39) can supply all necessary voltages for up to eight microphone assemblies. The polarization voltage may be 0, 28 or 200 V and manual, automatic or external scanning may be selected. The 2811 has a built in IEC/IEEC interface.

Outdoor Microphone Unit 4921

The Outdoor Microphone Unit Type 4921 (Fig. 37) has been designed to allow permanent outdoor noise monitoring. It consists of the 1/2" quartz-coated microphone Type 4149 fitted with Windscreen UA 0570, Rain Cover UA 0393 and a preamplifier all mounted on a stainless steel tube. A weather-proof case, to which the steel tube is connected, contains power supply, amplifier, calibration generator and a dehumidification system. Several different output possibilities are available to suit any particular measuring requirement. Moreover facilities for remote control and external supply of power and calibration signal are included. For further information see system development sheet "Airport Noise Monitoring Systems".

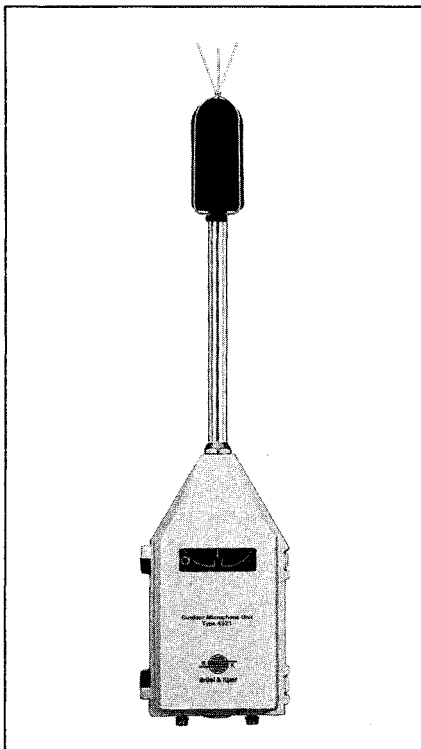

Fig. 37. Outdoor Microphone Unit Type 4921

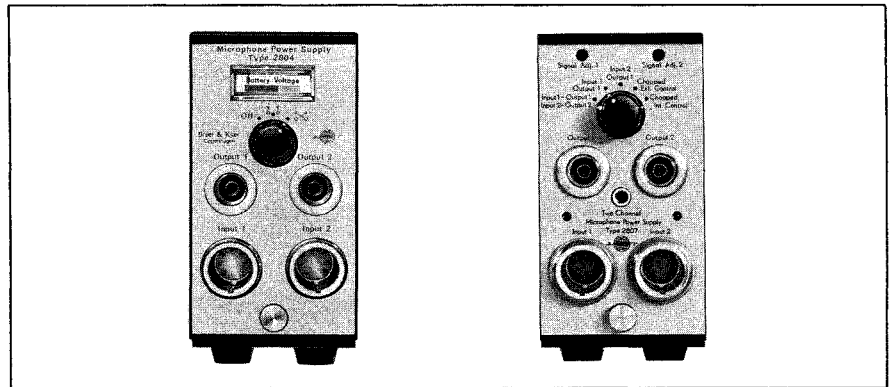

Fig. 38. Power Supplies Types 2804 and 2807

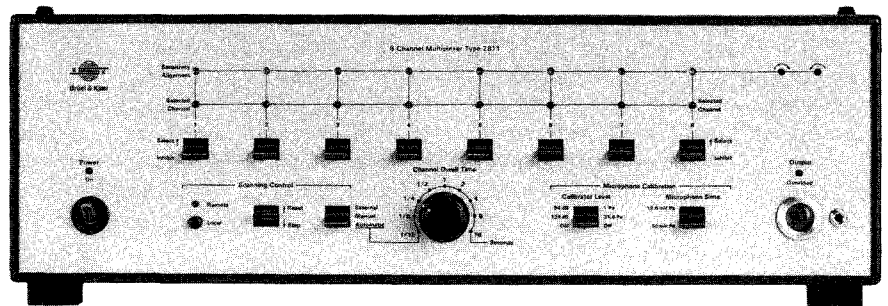

Fig. 39. Eight Channel Multiplexer Type 2811

Microphone Carrier System 2631

The Microphone Carrier System Type 2631 (Fig. 40) is made for measurement of low frequency pressure variations and shock waves and should be used with the microphone cartridge Type 4147. It supplies a carrier frequency of 10 MHz to the microphone cartridge instead of the normal 200 V polarization voltage.

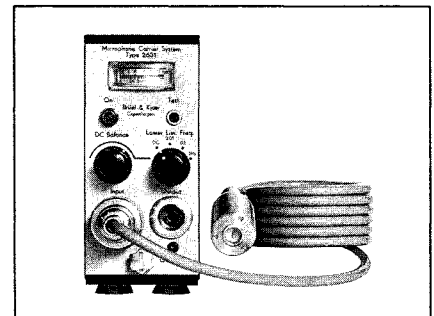

Fig. 40. Microphone Carrier System Type 2631

Artificial Ears, Ear Simulator and Couplers

The Artificial Ears Type 4152 and 4153, Ear Simulator Type 4157 (Fig. 41) and the couplers DB 0138, DB 0909, and DB 0161 have been developed for measurements on head-

and earphones.

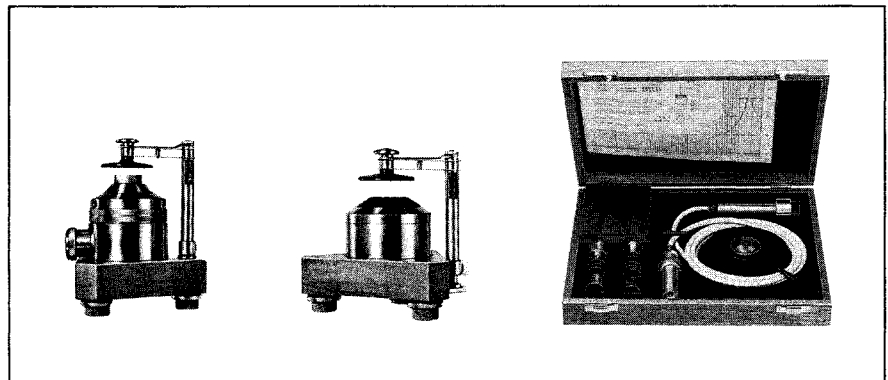

Fig. 41. Artificial Ears Types 4152 and 4153, and Ear Simulator Type 4157

Sealing Kit UA 0240

This kit (Fig. 42) is for sealing cartridge Types 4144 and 4145 so that measurements down to 0,1 Hz can be made.

Dehumidifier UA 0308

Use of dehumidifier is recommended in any situation where humidity may affect measurements.

The 1/2" diameter Dehumidifier UA 0308 (Fig. 43) is designed to be mounted between a microphone pre-amplifier or a sound level meter, and a backvented 1/2" condenser microphone cartridge. It contains silica gel and effectively removes humidity from the air in the microphone. A small window in the Dehumidifier's case allows the humidity content in the silica gel to be controlled, as the gel changes colour from blue in dry state to red when saturated. By heating for some hours at 100°C, or longer at lower temperatures, the gel is easily dried out again. When used in 100% RH the Dehumidifier requires drying-out approximately once a month.

Flexible Adaptors UA 0122 and UA 0123

The Flexible Adaptors (Fig. 44) allow the 1/2" and 1/4" microphones to be mounted on the 1/2" preamplifiers. The UA 0123 has a straight connector while the UA 0122 has a right angled connector. The flexibility of the adaptors makes the microphone assembly less sensitive to mechanical vibration and high temperatures

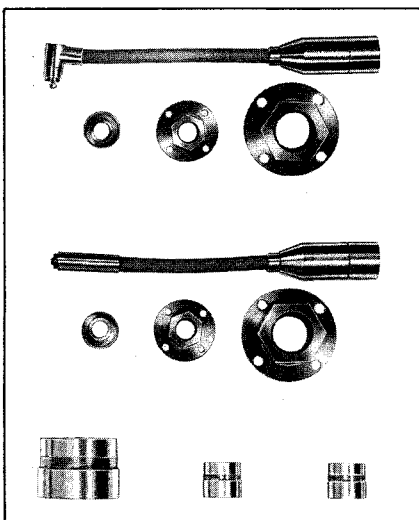

Fig. 44. Adaptors UA 0122, UA 0123, DB 0225, DB 0264 and DB 0900

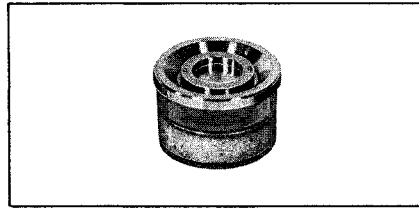

Fig. 42. Sealing Kit UA 0240

(150°C). Both sets are delivered with adaptors for flush mounting of the microphone for measurement of turbulence and other pressure variations in the plane of a surface.

Adaptor DB 0025

The 1/2" to 1" Adaptor DB 0225 (Fig. 44) screws onto the 1/2" microphones to give them the same external dimensions as the 1" microphones. For use of 1/2" microphones with 1" standard couplers, or 1" actuator with 1/2" microphones.

Adaptor DB 0264

The 1/4" to 1/2" Adaptor DB 0264 (Fig. 44) screws onto the 1/4" microphones to give them the same external dimensions as the 1/2" microphones. For use of 1/2" accessories with 1/4" microphones, e.g. with 1/2" actuator.

Adaptor DB 0900

The 1/8" to 1/2" Adaptor DB 0900 (Fig. 44) screws onto the 1/8" microphone to give it the same external dimensions as the 1/2" microphones. For use of 1/2" accessories with the 1/8" microphone, e.g. 1/2" actuator.

Portable Floor Stand UA 0587

This portable tripod (Fig. 45) is of rugged construction. The microphone assembly is held in position

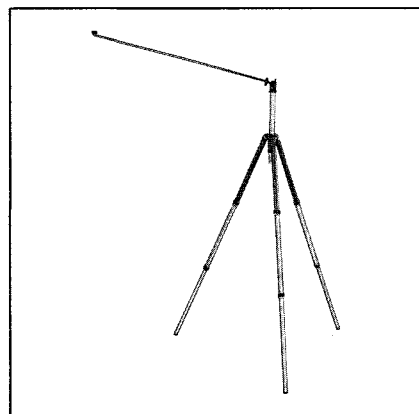

Fig. 45. Portable Floor Stand UA 0587 fitted with Adaptor UA 0588

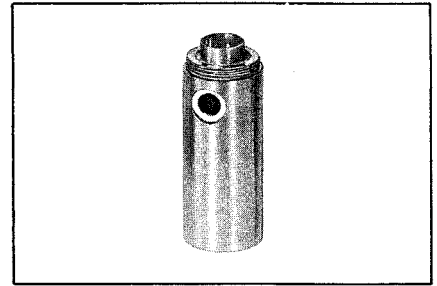

Fig. 43. 1/2" Dehumidifier UA 0308

by means of the Tripod Adaptor UA 0588 which is included with the tripod. Height of the tripod is adjustable from 50 to 140 cm. The Adaptor UA 0588 may be ordered separately for use on any stand with 3/8" W thread. A 3/8" W to 1/4" W adaptor DB 1112 is supplied with the tripod, which is also suitable for mounting Sound Level Meters.

NB. The Adaptor UA 0588 does not accept the 1/4" Preamplifier Type 2633.

Rotating Microphone Boom Type 3923

The 3923 (Fig. 46) is designed for use in sound power measurements to ISO 3741 and in building acoustics. It is battery powered, from rechargeable NiCd-cells, but can also be operated from mains via the battery charger ZG 0113. It has rotation times of 16, 32 and 64 s and a built-in microswitch allows synchronization of external equipment. The length of the boom can be varied from 50 cm to 200 cm.

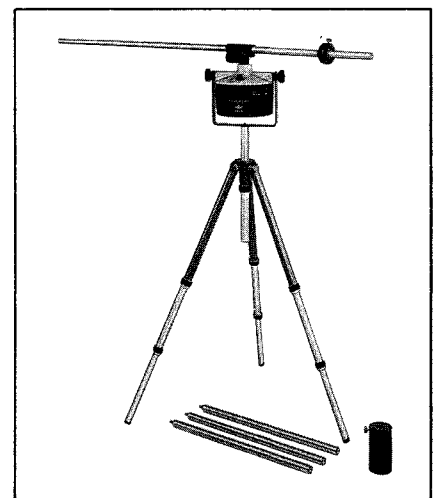

Fig. 46. Rotating Microphone Boom Type 3923 mounted on a tripod

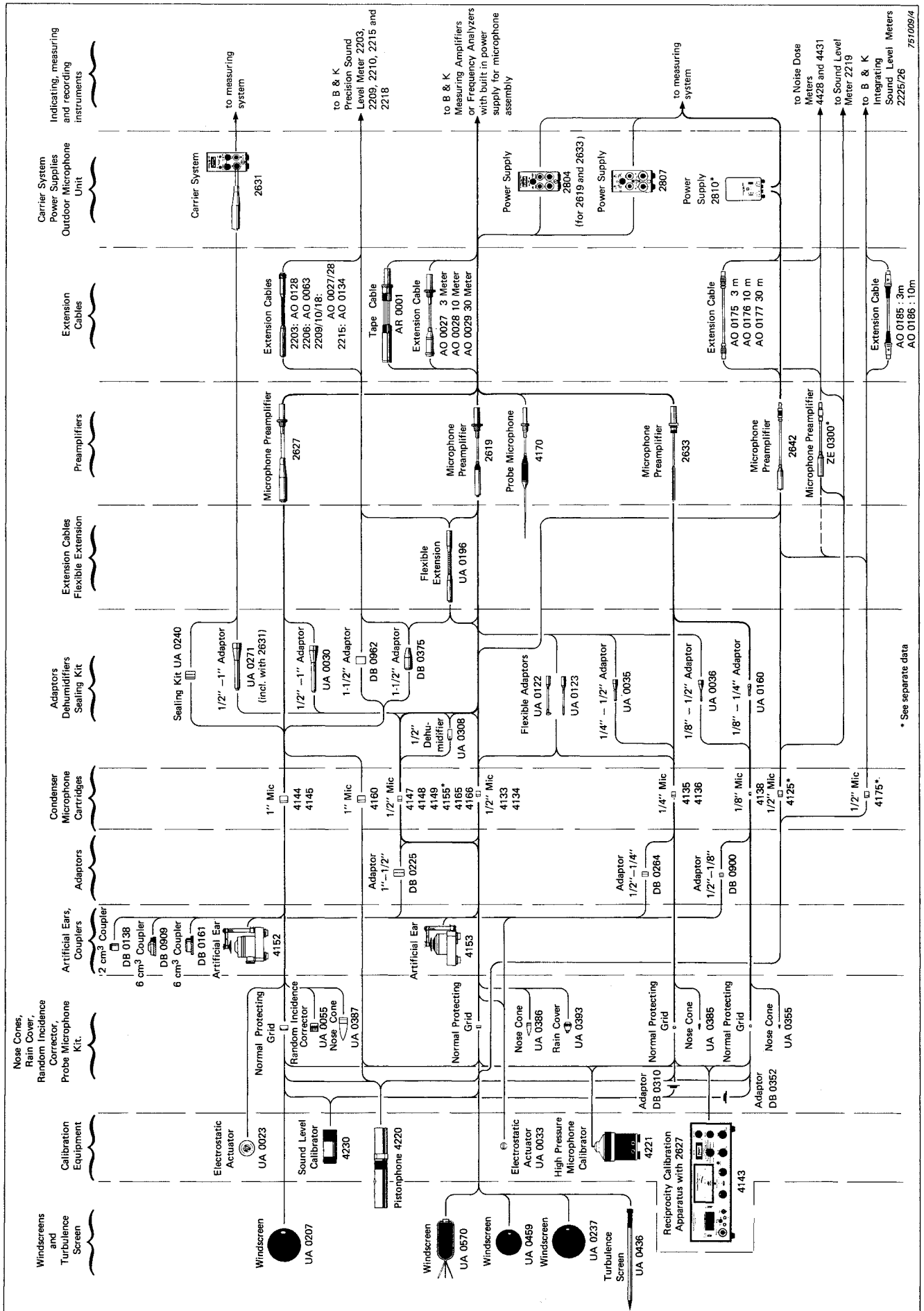

Fig. 47. Survey of adaptors and accessories for the condenser microphone cartridges

Specifications

148 130

Type No.	4144	4145	4160	4133, 4149	4134	4147 ^{a)}	4148	4105	4106	4135	4136	4138
Nominal Diameter	1"			1/2"			1/4"			1/8"		
Frequency Response Characteristic	Free-Field Incidence	Pressure	Random Incidence & Pressure	Free-Field Incidence	Random Incidence & Pressure	Free-Field Incidence	Random Incidence & Pressure	Free-Field Incidence	Random Incidence & Pressure	Free-Field Incidence	Random Incidence & Pressure	Random Incidence & Pressure
Open Circuit Frequency Response* (± 2 dB)	2,6 Hz to 8 kHz	4 Hz - 8 kHz ± 1 dB	4 Hz to 20 kHz	4 Hz to 40 kHz	4 Hz to 20 kHz	4 Hz to 16 kHz	2,6 Hz to 9 kHz	2,6 Hz to 20 kHz	4 Hz to 100 kHz	4 Hz to 70 kHz	4 Hz to 70 kHz	6,5 Hz to 140 kHz
Open Circuit Sensitivity* dB re. 1V/Pa	50	48,5	12,5	12,5	12,5	12,5	50	12,5	4	1,6	1,6	1,0
Lower Limiting Frequency, -3 dB	-26	-26,5	-38	-38	-38	-38	-26	-26	-48	-56	-56	-60
Cartridge Thermal Noise (dB(A))	9,5	9,5	18	18	18	18	15	14,5	29,5	30,5	30,5	—
Open Circuit Distortion Limit, 3% (dB re. 20 μ Pa)	>146	>160	>160	>160	>160	>160	>146	>140	>164	>172	>172	>168
Resonance Frequency	8 kHz	8,5 kHz	23 kHz	24 kHz	23 kHz	11 kHz	11 kHz	14 kHz	100 kHz	70 kHz	70 kHz	160 kHz
Polarization Voltage (V)	200			200			28			200		
Polarized Cartridge Capacitance at 250 Hz*	55 pF	55 pF	19,5	18,5 pF	19,5	17 pF	21 pF	19 pF	6,4 pF	6,4 pF	6,4 pF	3,5 pF
Mean Temperature Coefficient -10°C to +50°C (dB/°C)	-0,003	-0,003	-0,002	-0,002	-0,002	-0,015	-0,007	-0,007	-0,01	-0,01	-0,01	0,1
Equivalent Air Volume at 1 atm. (mm ³)	148	148	10	10	10	80	40	40	0,6	0,25	0,25	0,1
Expected Long Term Stability	> 1000 years/dB (> 200 years/dB ^{b)})			> 1000 years/dB (> 200 years/dB ^{b)})			> 600 years/dB			—		
Influence of Static Pressure at 250 Hz (dB/mbar)	-0,0016	-0,0015	-0,0016	-0,0007	-0,00025	-0,0016	-0,001	-0,001	-0,0007	-0,00025	-0,00025	-0,001
Influence of 1 m/s ² Axial Vibration (dB re. 20 μ Pa) ^{c)}	67			67			60			59		
Influence of 50 Hz, 80 A/m magnetic field (dB re. 20 μ Pa) ^{c)}	18			20			28			30		
Influence of Relative Humidity	0,0025 dB/100% RH			< 0,1 dB in the absence of condensation			0,004 dB/%RH			< 0,1 dB in the absence of condensation		
Height of Cartridge: Without Protection Grid With Protection Grid	17 mm 19 mm	19 mm 19,35 mm	11,5 mm 12,6 mm	15,2 mm 16,3 mm	15,2 mm 16,3 mm	15,2 mm 16,3 mm	9,0 mm 10,5 mm	9,0 mm 10,5 mm	9,0 mm 10,5 mm	9,0 mm 10,5 mm	9,0 mm 10,5 mm	6 mm 6,7 mm
Diameter of Cartridge: Without Protection Grid With Protection Grid	23,77 mm 23,77 mm	23,77 mm 23,77 mm	12,7 mm 13,2 mm	12,7 mm 13,2 mm	12,7 mm 13,2 mm	12,7 mm 13,2 mm	6,35 mm 7 mm	6,35 mm 7 mm	6,35 mm 7 mm	6,35 mm 7 mm	6,35 mm 7 mm	3,175 mm 3,5 mm
Thread for Protection Grid or Coupler Mounting	23,11 mm — 60 UNS			12,7 mm — 60 UNS			12,7 mm — 60 UNS			6,35 mm — 60 UNS		
Thread for Preampifier Mounting	23,11 mm — 60 UNS			11,7 mm — 60 UNS			11,7 mm — 60 UNS			5,7 mm — 60 UNS		

a) For specifications with 10 MHz carrier, see data sheet for Microphone Carrier System Type 2631

b) Type 4149

c) Typical value

individually calibrated

types 2619, 2627 and 2633

FEATURES:

- Small compact construction
- High input impedance
- Low output impedance
- Wide dynamic range
- Adapts to microphones with different diameters

ADDITIONAL FEATURES

TYPE 2627:

- Insert voltage calibration capability
- Standardized input configuration
- Conforms with IEC R 327 and ANSI S1.10-1966
- Attenuation < 0,08 dB

USES:

- Sound measurements with B & K condenser microphones
- General purpose transducer preamplifier
- High impedance input probe for B & K measuring amplifiers and frequency analyzers

ADDITIONAL USES

TYPE 2627:

- Insert voltage calibration of condenser microphones for open circuit voltage determination
- Calibration of microphones in connection with reciprocity calibration apparatus
- Calibration of sound measuring set-ups

Microphone Preamplifiers

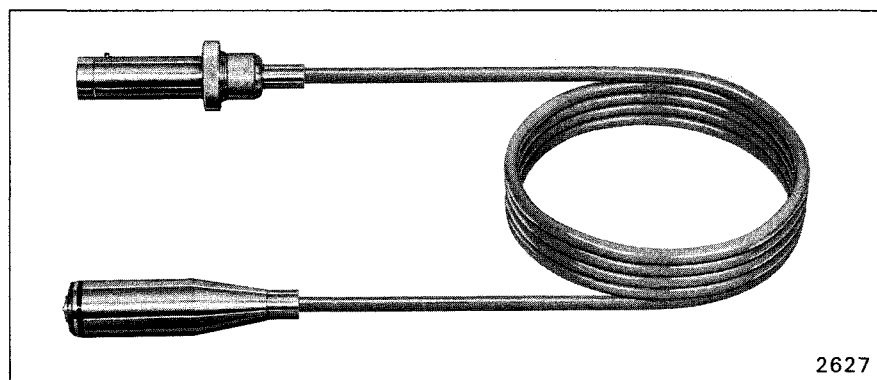
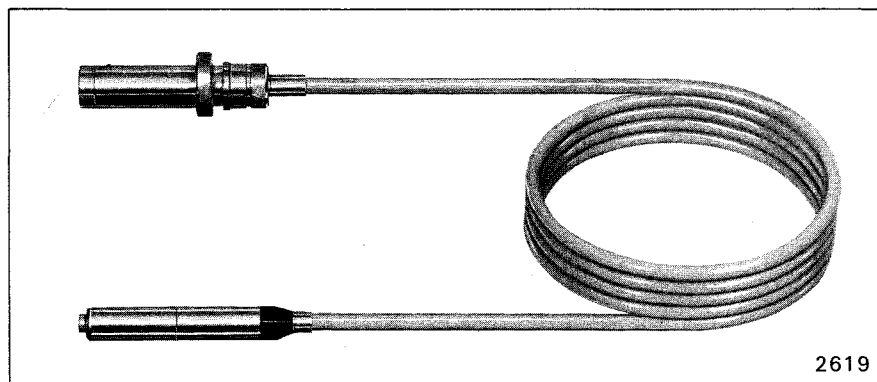
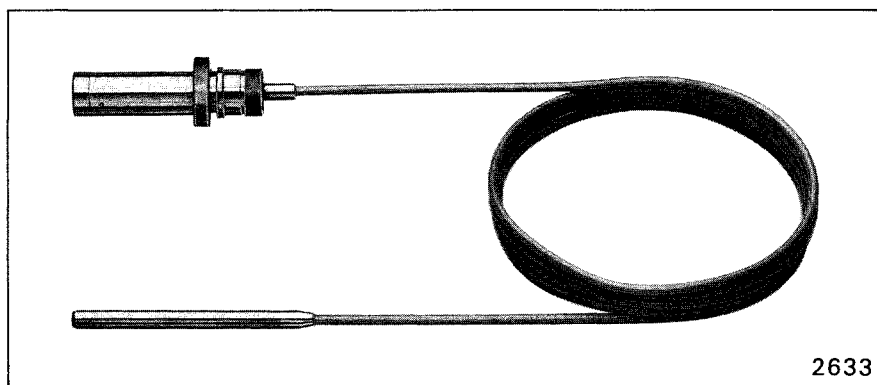

The Preamplifiers Type 2619, 2627 and 2633 are designed especially to match the needs of the B & K condenser microphones but may find application whenever a very high input impedance is required from the B & K Measuring Amplifiers and Frequency Analyzers. They are small and compact in design and operate over a wide range of temperature, humidity and other environmental effects. The preamplifiers have a very high input impedance and present virtually no load to the microphone cartridges. This together with a very low inherent noise level, gives a low lower limiting frequency and a wide dynamic range. The low output impedance allows the connection of long cables between the preamplifier and the measuring instrument.

The preamplifiers are supplied

with power via a 7 core cable from the 7 pin preamplifier input socket on the B & K Measuring Amplifiers and Frequency Analyzers. Special power supplies are available for use if it is required to connect the preamplifier to other instrumentation. The polarization voltage for the microphone cartridge is supplied by the same input socket or power supply via the 7 core cable of the preamplifier and the preamplifier itself. Input adaptors connected instead of the microphone cartridges block this polarization voltage and allow connection of other transducers such as an accelerometer. Also they allow the preamplifier to be used as a general purpose high impedance input probe.

Fig.1 shows how the preamplifiers fit to the different microphones and the adaptors for direct electrical

input. The Dehumidifier shown is used with special microphones as indicated for measurements in humid atmospheres over longer periods of time.

For use with Microphones Type 4125 and 4175, a low cost preamplifier Type 2642 is available. Please ask for separate Data Sheets.

N.B. Use of the Prepolarized Microphone Type 4155 with the Preamplifier Type 2619 requires the disconnection and grounding of the polarization voltage on earlier instruments. Current instruments are provided with a 0—28—200 V selector. Please see the Type 4155/4175 Data Sheet.

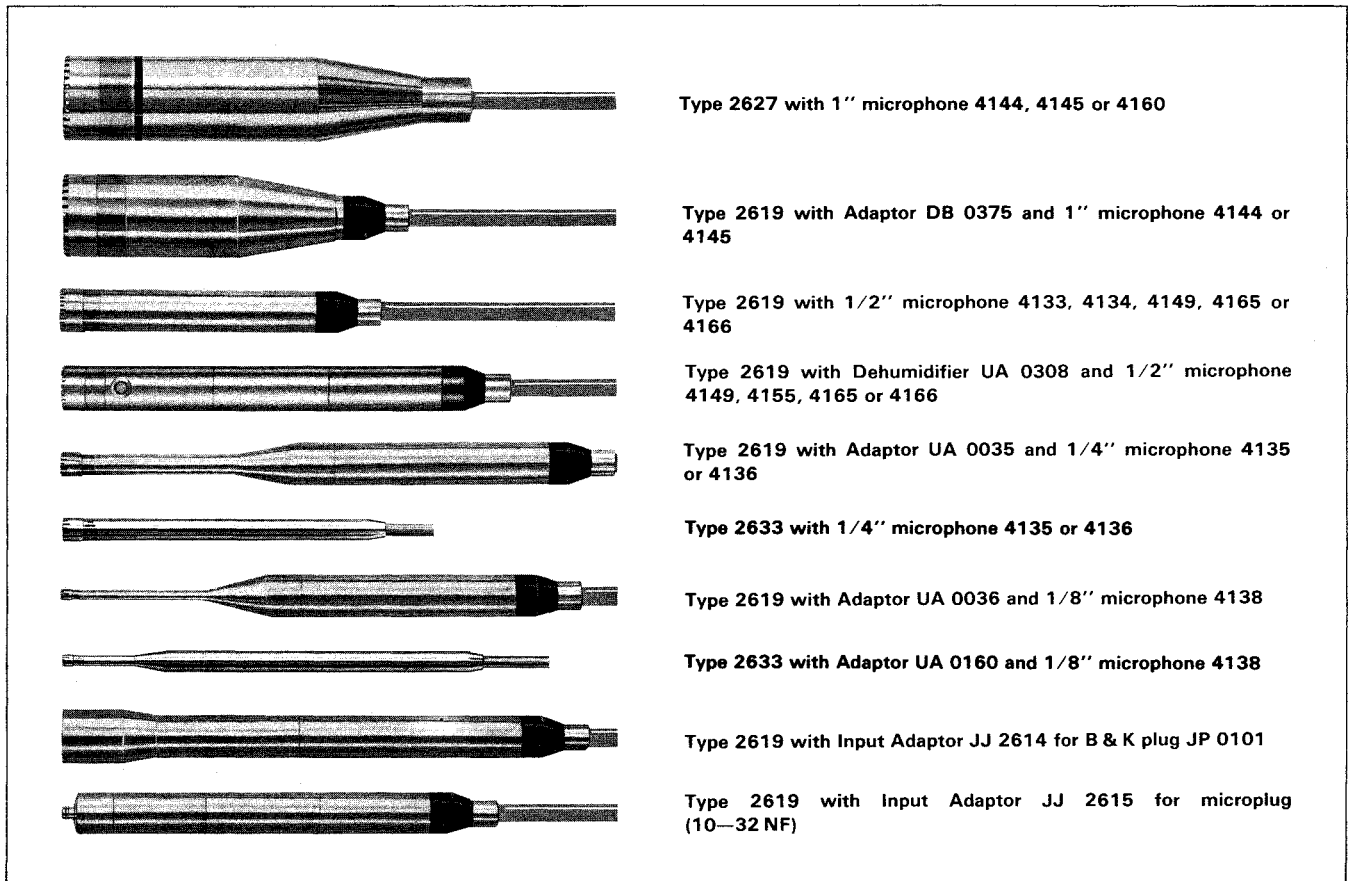

Fig.1. Adaptors required to connect B & K Condenser Microphones and direct electrical signals to the Preamplifiers Types 2633, 2619 and 2627

Preamplifier 2619

This preamplifier fits directly onto the 1/2" microphone cartridges and adapts to the 1", 1/4" and 1/8" cartridges. It has a high input impedance and low inherent noise,

and can be operated either from a 120V supply, or from a 28V supply, such as the battery driven Microphone Power Supply 2804. A heater element is built into the tip of

the preamplifier to prevent condensation forming in the microphone if it is used in very humid environments.



Fig.2. Type 2619S as delivered in mahogany case with accessories

Additional protection is obtained using the Dehumidifiers and special microphones. If the 2619 is used with the Power Supply 2804 the current for the heater element must be supplied separately. The 2619 is delivered either as 2619S in a mahogany case containing the preamplifier, two adaptors and a flexible extension rod, or as 2619T in a plastic box containing only the preamplifier. The adaptors delivered with 2619S are the DB 0375

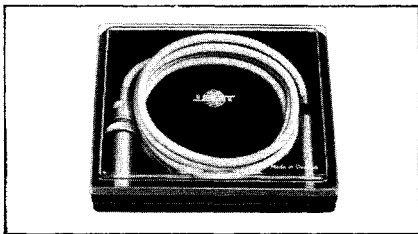

Fig.3. Type 2619T as delivered in plastic box

which allows 1" microphones to be used and the JJ 2615 allowing cables with microplugs to be connected (B & K no. AO 0038/0089/0122). The Flexible

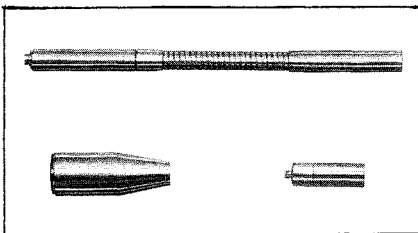

Fig.4. Flexible Extension Rod UA 0196, Adaptor DB 0375 and Adaptor JJ 2615

Extension Rod UA 0196 is used to increase the distance between the preamplifier and the microphone and to give directional flexibility to the microphone. Increased distance between preamplifier and transducer allows measurement at higher temperatures (150°C, 302°F).

Preamplifier 2633

This preamplifier is only 1/4" in diameter and fits directly to the 1/4" microphone cartridges while the 1/8" cartridges are fitted by means of the Adaptor UA 0160. The preamplifier has a high input impedance and low inherent noise.

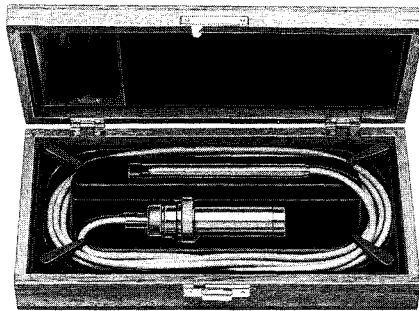

Fig.5. The 2633 as delivered in mahogany case

Preamplifier 2627

This preamplifier has been designed especially to allow calibration of the 1 inch B & K condenser microphone cartridges according to the insert voltage method either in connection with reciprocity calibration or by comparison with a known sound source. These methods are described in the IEC recommendation R 327 and in the American standard ANSI S1.10-1966.

The Type 2627 fulfils these recommendations and allows insert calibration to be made with Types 2610 and 2636 Measuring Amplifiers using external junction box ZH 0007 and an external oscillator. Some amplifiers and analyzers, e.g. Types 2606, 2607 (earlier types) 2010 and 2120 have a direct insert voltage calibration facility.

The preamplifier may be used in either driven shield or grounded

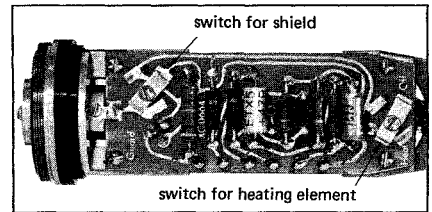

Fig.6. View of the preamplifier with the housing removed, showing the contacts for connection/disconnection of the heating element and for grounding/driving the shield around the input contact to the output

shield configurations in order to be in complete agreement with methods used in standards laboratories throughout the world.

It contains an input stage, an output stage giving a low output impedance and the supply for the driven shield surrounding the input stage that minimises stray capacitances. The thread for the microphone cartridge is isolated from the preamplifier housing to allow an insert voltage to be applied in series with the microphone for finding its open circuit sensitivity. A heating element is built into the preamplifier to prevent condensation forming in the microphone or preamplifier when used in very moist environments. The heating element can be disconnected by means of a small switch situated on the printed circuit board. See Fig.6. This allows microphone calibration to be made without any temperature influence from the preamplifier.

The shield around the input contact can be connected either to the output or to the ground by means of

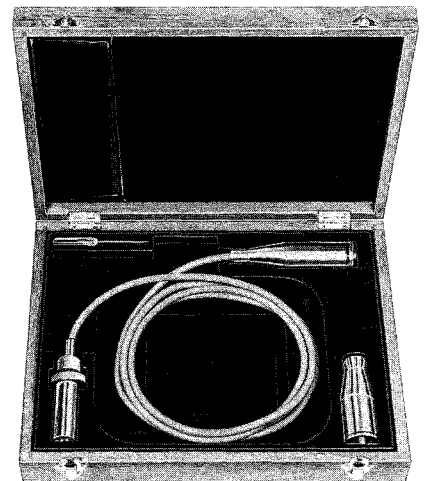

Fig.7. The Preamplifier Type 2627 as delivered in mahogany case

another switch also shown in Fig.6. This allows use of either a driven or a grounded shield.

During design and manufacture of the preamplifier special attention has been given to keeping stray capacitances and leakage resistances at a minimum also when the preamplifier is used in moist environments. A double screening secures very low cross-talk (better than -60 dB at 1 kHz).

Insert Voltage Calibration. This type of calibration is used to find the open circuit sensitivity of a microphone, which is defined as the voltage appearing at its terminals when the microphone is working into an infinitely large electrical impedance and standardised mechanical configuration. It is measured by the substitution method where a known sound pressure is applied to the microphone diaphragm alternately with a calibration voltage applied in series with the microphone when the microphone is terminated in the same acoustic impedance. The calibration voltage is adjusted until the output voltage from the preamplifier is the same as when a given sound pressure is acting on the microphone diaphragm in the absence of the calibrating voltage. The open circuit sensitivity is then equal in magnitude to the calibra-

tion voltage divided by the sound pressure applied.

Insert Voltage Calibration with B & K Equipment. The Preamplifier 2627 connects directly to the 7-pin preamplifier input of the Measuring Amplifiers Types 2606 and 2607 (earlier types) and the Frequency Analyzers Types 2010 and 2120. The input socket of these instruments delivers all necessary voltages for the preamplifier and the polarization voltage (200 V) for the microphone cartridge. The insert calibration voltage, which is also supplied via this socket, may originate either from the 1000 Hz reference oscillator built into these instruments or from an external signal source, for instance the Sine Generator 1023, in order to allow calibration at other frequencies and levels. For other instruments, including Measuring Amplifiers Types 2610 and 2636, external junction box ZH 0007 and an external oscillator must be used. As a sound source the Sound Level Calibrator Type 4230 working at 1000 Hz or the Pistonphone Type 4220 working at 250 Hz may be used.

The Preamplifier Type 2627 is also delivered with the Reciprocity Calibration Apparatus Type 4143 which is designed for reciprocity calibration of 1" condenser micro-

phones in accordance with IEC 327 and 402, insert voltage calibration, comparison calibration and measurement of the frequency response of condenser microphones by the electrostatic actuator method.

Application Ranges

The preamplifier Type 2619 in connection with a 1/2" or 1" condenser microphone creates a microphone assembly well suited for most sound measurements. The 2633 with a 1/4" or 1/8" microphone is specially designed for high intensity, high frequency applications. The small size and compact construction make it ideal for such applications as jet noise and boundary layer investigations.

The Type 2627 which is primarily designed for use where the insert voltage calibration technique is applied can be used with all B & K 1" condenser microphones for sound measurements. Special features for this purpose are a very low inherent noise level, and a very small attenuation. With an adaptor UA 0030 also 1/2" microphones can be fitted.

Accessories

The preamplifiers are delivered with certain standard accessories as described. Full information on accessories available for use with the B & K condenser microphones and preamplifiers are given in the data sheet for the microphone cartridges.

Extension cables

Three standard length extension cables are available. The cables have a very low capacitance and extremely good shielding so that several lengths can be connected together. The influence on distortion and high frequency response can be seen from Fig.12 to Fig.17. The table below gives the capacitance, diameter and length of the cables.

Extension Cable Type	AO 0027	AO 0028	AO 0029
Length	3 m 10 ft	10 m 33 ft	30 m 100 ft
Diameter	6 mm 1/4"	9 mm 3/8"	9 mm 3/8"
Capacitance to ground of the signal conductor	300 pF (100 pF/m)	570 pF (57 pF/m)	1700 pF (57 pF/m)

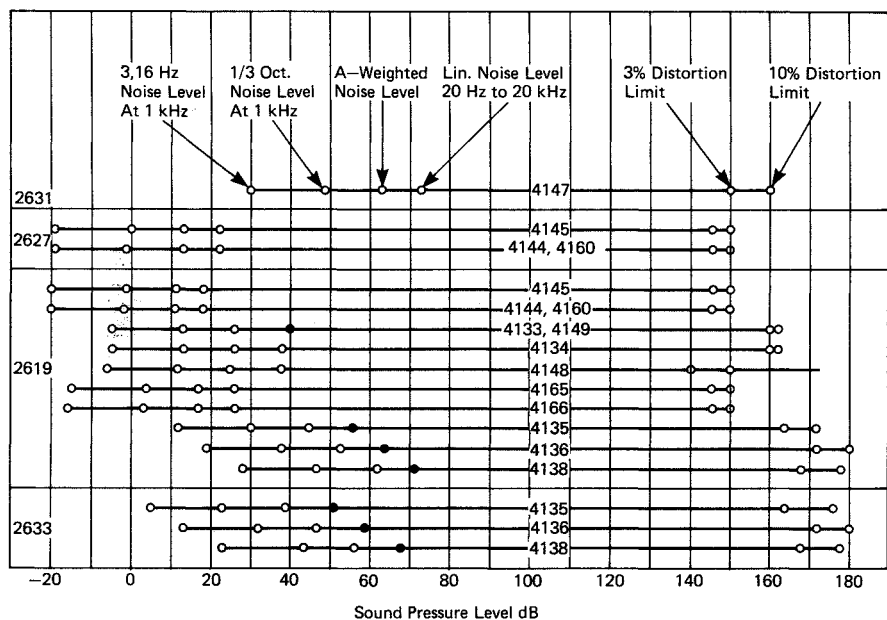

• Lin. 20 Hz to 200 kHz

820609

Fig.8. Compared dynamic ranges of all the B & K preamplifiers with different condenser microphones. For description of Type 2631 Carrier Frequency System see separate literature. The upper limits are indicated for two degrees of distortion while the lower limits are given for various bandwidths of the measuring equipment. The limits for 3,16 Hz and 1/3 octave bandwidths are valid at 1 kHz only

Tape Cable AR 0001

This very flat, flexible 7 core cable is used when it is necessary to carry an extension cable through closed windows, doors, etc. The flat cable can easily follow sharp bends, the thickness being only 0,2 mm. Length of the cable is 300 mm (12"). Typical applications are in sound insulation and reverberation measurements in buildings.

**Frequency Response —
Transducer Capacitance**

The frequency response of the preamplifiers depends on the trans-

ducer capacitance connected to the preamplifier input and the capacitance load (extension cables) connected to the output. The curves below show the frequency response of the preamplifiers with different B & K condenser microphone cartridges and no extension cables connected.

Typical B & K microphone capacitances are:

- Type 4144, 4145, and 4160 50 to 66 pF (1" dia.)
- Type 4125, 4133, 4134, 4147,

- 4148, 4149, 4155, 4165, 4166 and 4175 17 pF (1/2" diameter)
- Type 4135 and 4136: 6 pF (1/4" diameter)
- Type 4138: 3 pF (1/8" diameter)

The capacitance of the adaptors necessary to connect the cartridges to the preamplifiers has been included as indicated on the curves.

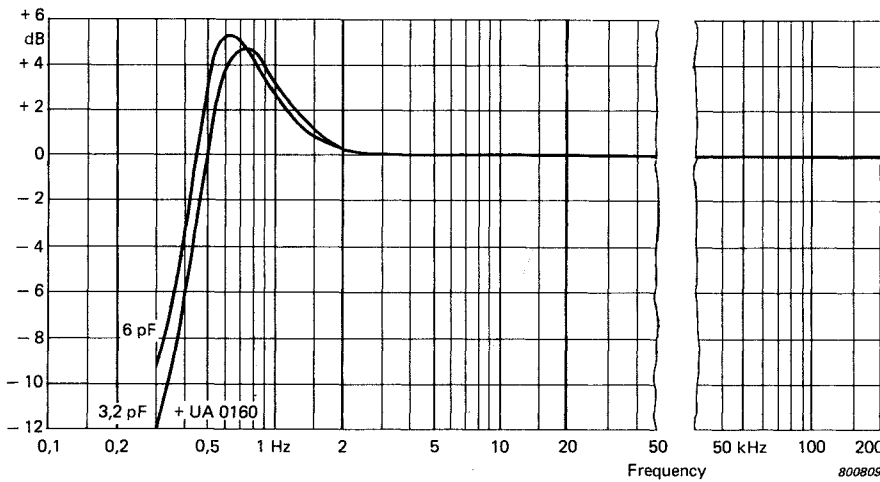

Fig.9. Preamplifier Type 2633. Frequency response curves with different transducer capacitances connected at the input

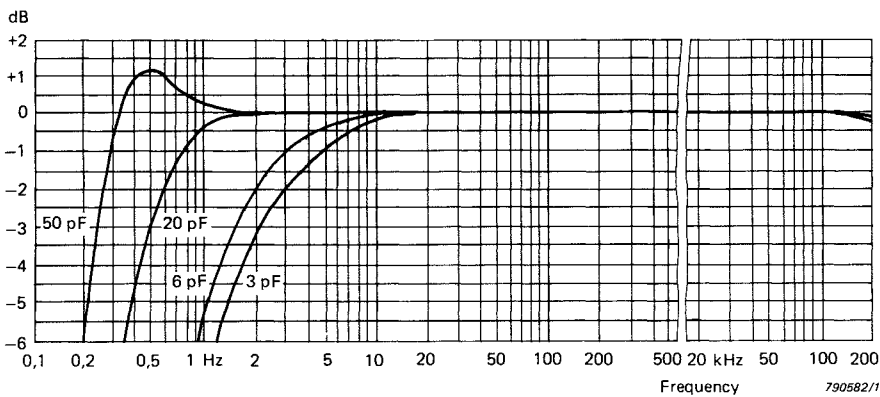

Fig.10. Preamplifier Type 2619. Frequency response curves with different transducer capacitances connected at the input

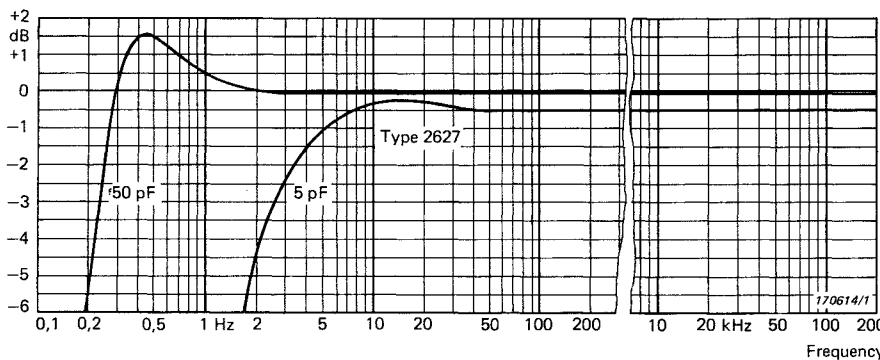

Fig.11. Preamplifier Type 2627. Frequency response curve of the preamplifier unloaded and an input capacitance of 50 pF corresponding to 1" microphone. Lower curve with 5 pF input capacitance indicates the influence on frequency response of varying input capacitances. With 50 pF input capacitance the response is linear from 2 Hz to 200 kHz ± 0,5 dB

Loading — Frequency Response

The capacitive load of extension cables on the output of the preamplifiers will influence the frequency response and the upper distortion limit. The curves below show the in-

fluence on the high frequency cut-off at different load capacitances and different transducer capacitances corresponding to those of the B & K condenser microphone cartridges. When determining the total

frequency response of the preamplifier with extension cables these curves should be held together with the curves given for Frequency Response-Transducer Capacitance.

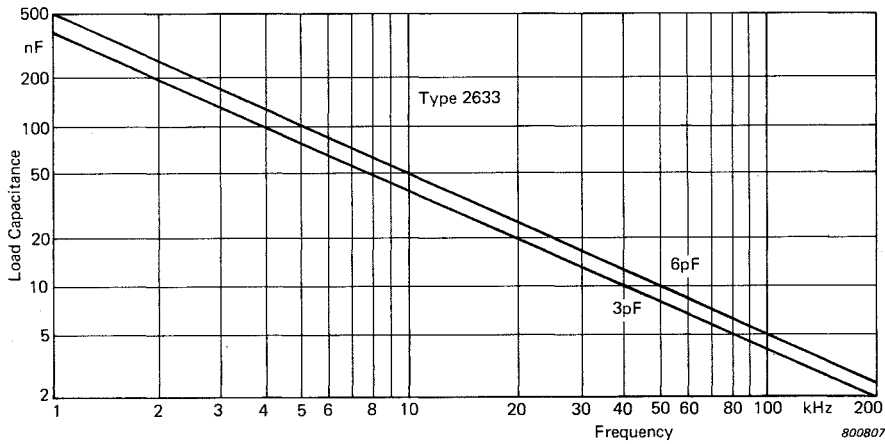

Fig.12. Preamplifier Type 2633. Upper frequency limit (-1 dB) as a function of load (extension cable capacitance) for different transducer capacitances

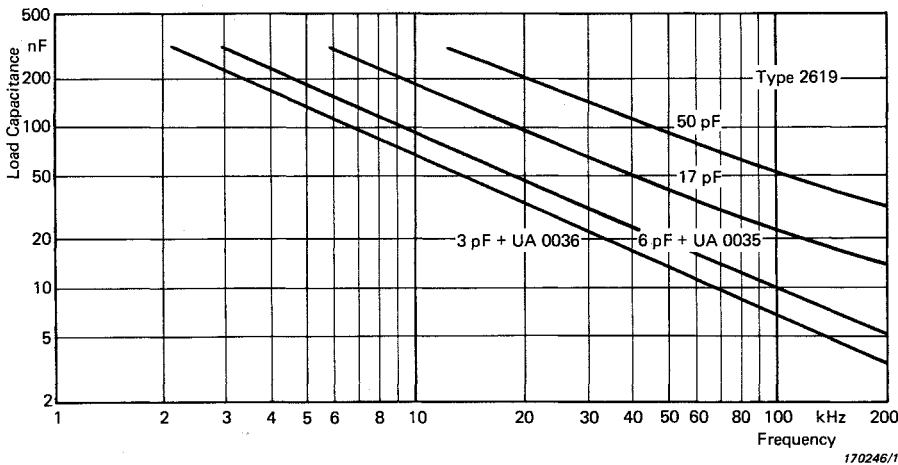

Fig.13. Preamplifier Type 2619. Upper frequency limit (-1 dB) as a function of load (extension cable capacitance) for different transducer capacitances

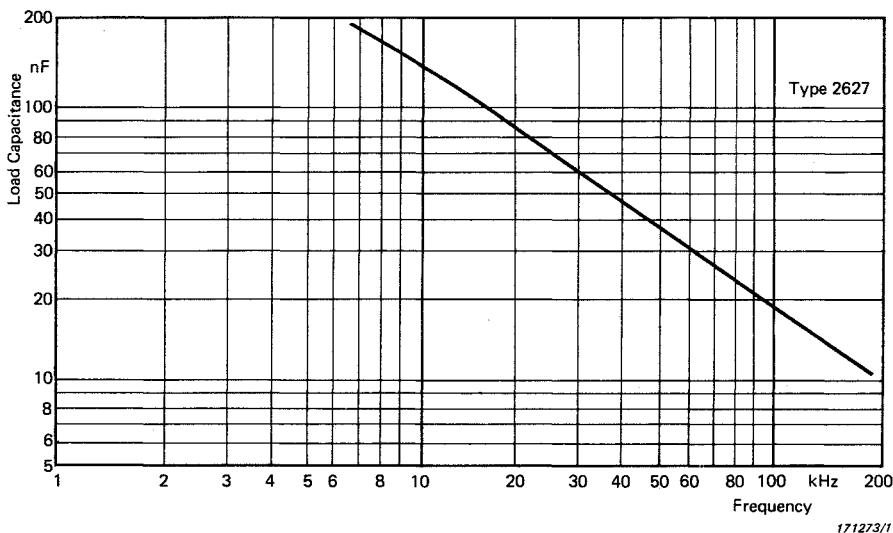

Fig.14. Preamplifier Type 2627. Upper frequency limit (-1 dB) as a function of load (extension cable capacitance) at 50 pF transducer capacitance

Loading — Distortion

If the maximum output current of the preamplifier is exceeded the signal will be distorted. The curves be-

low give the upper distortion limit (4%) as a function of output voltage and load capacitance at the output

of the preamplifier. For normal cable lengths the distortion will be lower than 1%.

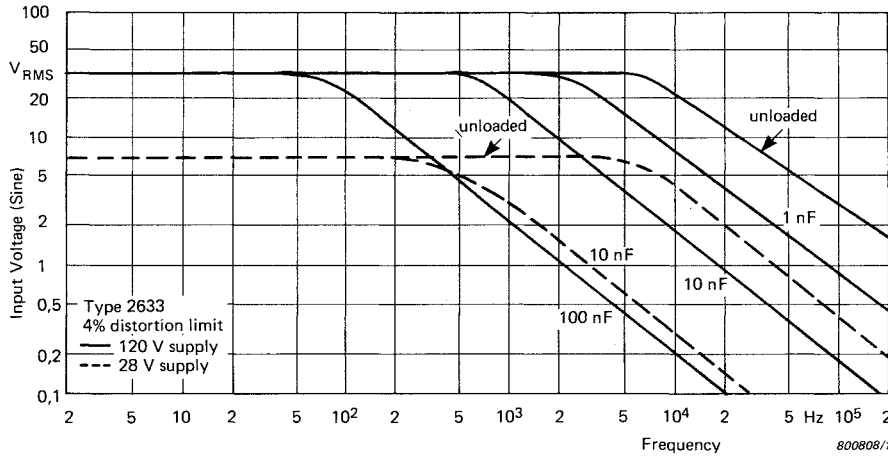

Fig.15. Preamplifier Type 2633. Upper limit of dynamic range (4% distortion) due to capacitive loading as a function of input voltage and frequency

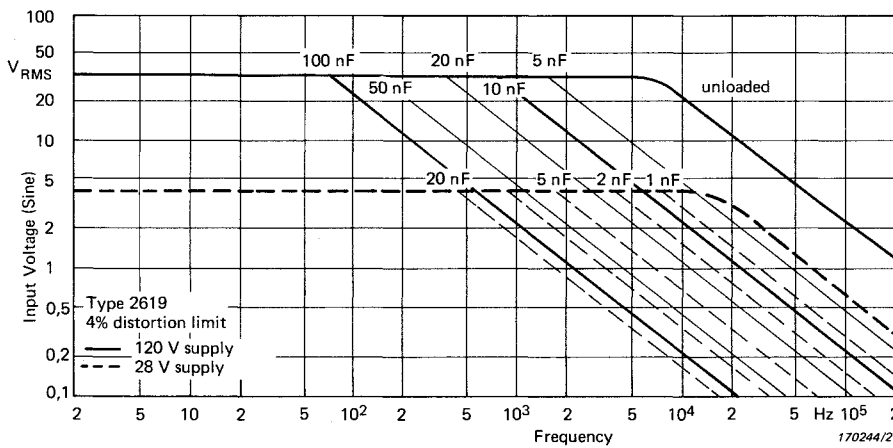

Fig.16. Preamplifier Type 2619. Upper limit of dynamic range (4% distortion) due to capacitive loading as a function of input voltage and frequency

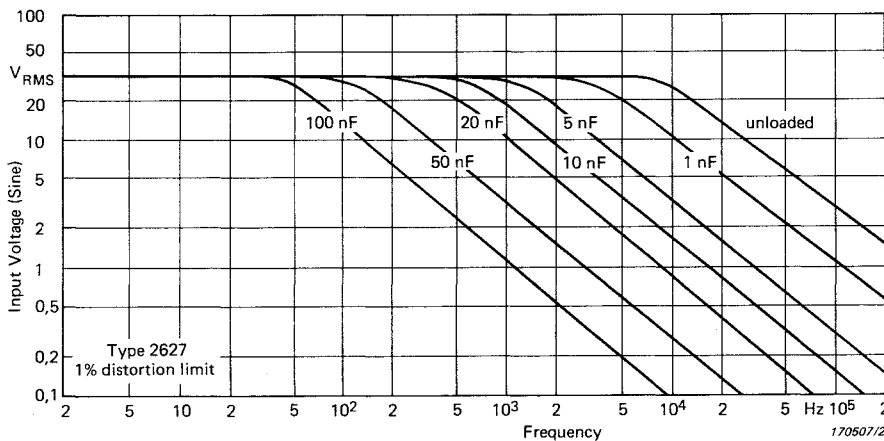

Fig.17. Preamplifier 2627. Upper limit of dynamic range (1% distortion) due to capacitive loading (extension cables) as a function of input voltage and frequency

Specifications 2619, 2627 and 2633

B & K Type no.	2633		2619		2627
DC Power Supply	120 V/2 mA	28 V/0,5 mA	120 V/2 mA	28 V/0,5 mA	120 V/2 mA
	Heater 12 V / 80 mA			Heater 12 V/60 mA	
Polarization Voltage	Transmitted through preamplifier to microphone cartridge from power supply				
Input Impedance	>50 GΩ//0,25 pF at 60°C (approx. 5 GΩ//0,25 pF at 100°C)	10 GΩ//0,4 pF (typical)	> 10 GΩ//0,8 pF	> 7 GΩ//1 pF	grounded shield: < 5 pF driven shield: > 10 GΩ//< 0,5 pF
Output Impedance	< 100 Ω	600 Ω (typical)	< 25 Ω	< 70 Ω	< 50 Ω
Max. Output Current	1,4 mA peak	0,25 mA peak (typical)	1,5 mA peak	0,5 mA peak	1,4 mA peak
Temp. Range	-20° to +60°C* (-4° to 140°F)		-20° to +60°C (-4° to +140°F)	-20° to +60°C (-4° to +140°F)	-10° to +60°C (14° to 140°F)
Attenuation (Preamplifier alone)	< 0,06 dB	< 0,1 dB	< 0,03 dB	< 0,1 dB	< 0,08 dB
Phase (20 Hz to 20 kHz)	± 2,0°		± 2,5°		± 2,0°
Linearity (2 Hz to 200 kHz)	+ 8°, -13° (6 pF)		+ 20°, -13° (20 pF)		+ 2°, -12° (50 pF)
Preamplifier Noise (dummy microphone): Lin. 20 Hz to 200 kHz and A-weighted. Typical values are given in parentheses					
60 pF (1" microphone)	—	—	<10 μV (7 μV) Lin. <2 μV (1,7 μV) A-weighted		<15 μV (9 μV) Lin. <3 μV (2,3 μV) A-weighted
17 pF (1/2" microphone)	—	—	<25 μV (12 μV) Lin. <4,5 μV (3,3 μV) A-weighted		—
6 pF (1/4" microphone)	<30 μV (19 μV) Lin. <7 μV (5,8 μV) A-weighted Approx. 150 μV, 34 μV at 100 °C		<50 μV (23 μV) Lin. <15 μV (7,5 μV) A-weighted		—
3,5 pF (1/8" microphone)	<50 μV (23 μV) Lin. <12 μV (7 μV) A-weighted		<70 μV (50 μV) Lin. <25 μV (14 μV) A-weighted		—
Dimensions:	Diameter: 6,35 mm (0,25 in) Length: 88 mm (3,46 in)		12,7 mm (0,5 in) 83 mm (3,25 in)		23,8 mm (0,936 in) 99 mm (3,9 in)
Cable Length	3,4 m (11,2 ft)		2 m (6,6 ft)		2 m (6,6 ft)

<p>Frequency Range: See Figs. 9, 10, and 11</p> <p>Distortion: See Figs. 15, 16, and 17</p> <p>Max. Input Voltage: See Figs. 15, 16, and 17</p> <p>Connection Type: B & K 7 pin plug</p> <p>Accessories Included: Type 2619S: Adaptor for 1" microphones DB 0375 Coaxial Input Adaptor JJ 2615 Flexible Extension Rod UA 0196</p>	<p>Type 2619T: None</p> <p>Type 2633: None</p> <p>Type 2627: Coaxial Input Adaptor JJ 2612 Small screwdriver QA 0001</p> <p>Accessories Available:</p> <p>Extension cables: AO 0027, length 3 m (10 ft) AO 0028, length 10 m (33 ft) AO 0029, length 30 m (100 ft)</p> <p>Tape Cable: AR 0001, length 300 mm (12")</p>	<p>UA 0588: Adaptor for mounting 1" and 1/2" microphone preamplifiers on tripods with 3/8" W thread</p> <p>Portable Floor Stand UA 0587: For Types 2619 and 2627 (includes adaptor UA 0588)</p> <p>Insert Voltage Junction Box ZH 0007: (for Type 2627 only)</p> <p>Microphone Power Supplies:</p> <p>Type 2804, 2 channel, battery driven, for Type 2619 and 2633 Type 2807, 2 channel, automatic switching between channels</p>
--	--	--

* Up to 100°C (212°F) with reduced specifications, see Input Impedance and Preamplifier Noise entries

2. THE CONDENSER MICROPHONE AND ITS PREAMPLIFIER

2.1. PRINCIPLE OF OPERATION

The condenser microphone has operating characteristics of high stability, flat response over a wide frequency range, reasonably high sensitivity, and very low internal noise. These qualities combined with its minimal effect on the sound field in which it is placed make it for many purposes the most suitable transducer available for measuring sound pressure.

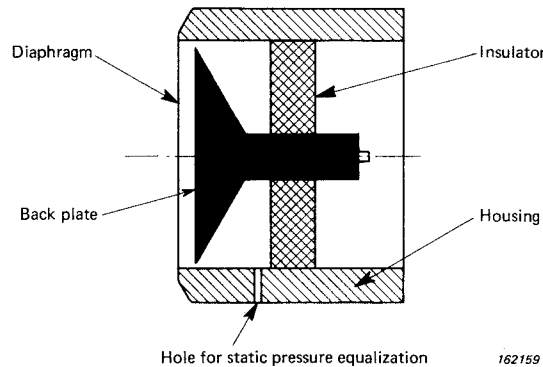

Fig.2.1. Schematic construction of a condenser microphone

The condenser microphone, shown in Fig.2.1, consists basically of a thin metal diaphragm and a rigid back plate constituting the electrodes of an air dielectric capacitor. If a constant charge is applied to the capacitor by a DC voltage (the polarization voltage), the variations in capacitance caused by the varying sound pressure on the thin diaphragm are transformed into voltage variations. Since static pressure variations can be bigger than the sound pressures normally encountered, a pressure equalization vent ensures that static pressure is the same inside and outside the cartridge cavity.

To increase the relative variation in capacitance, and thus increase the sensitivity, the stray capacitance of the condenser microphone and following amplifier input must be as small as possible. Therefore the microphone and the first amplifier stage, the preamplifier, are normally placed in close proximity. Furthermore, the small capacitance of the microphone requires a very high load resistance to ensure a low lower limiting frequency. So the preamplifier stage is designed as an impedance converter, providing the low output impedance required for signal transmission by a cable to the first stage of the sound analyzer system.

An equivalent circuit of the condenser microphone and microphone preamplifier is shown in Fig.2.2. A constant charge, Q , is applied to the diaphragm-backplate capacitor by connection of a DC voltage via a high impedance resistor, R_c . The polarization voltage, E_0 , and charge are related by Equation 2.1:

$$E_0 = \frac{Q}{C_t} \quad (2.1)$$

where C_t = the capacitance of the microphone cartridge.

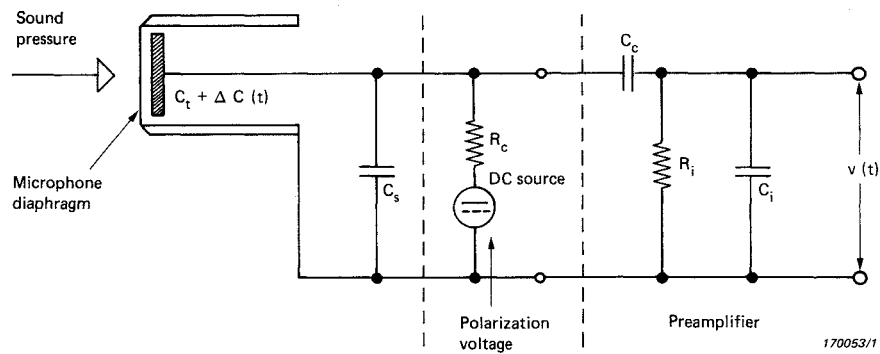

Fig. 2.2. Equivalent circuit of a condenser microphone and microphone preamplifier

where:

- C_t = Capacitance of the microphone cartridge
- $\Delta C(t)$ = Variation in capacitance due to incident sound pressure
- E_0 = Polarization voltage
- C_s = Stray capacitance
- C_c = Coupling capacitance
- C_i = Preamplifier input capacitance
- R_c = Resistance of charging circuit
- R_i = Preamplifier input resistance
- $v(t)$ = Output voltage

Since the charge on the capacitor is held constant, the variation in capacitance due to a change in sound pressure is transformed into a variation in voltage. When unloaded, the cartridge open circuit output voltage, $v_o(t)$, is given by:

$$v_o(t) = \frac{\Delta C(t) \cdot E_0}{C_t + \Delta C(t)} \approx \frac{\Delta C(t) \cdot E_0}{C_t} \quad \text{since } C_t \gg \Delta C(t) \quad (2.2)$$

The microphone cartridge is connected to the preamplifier via a coupling capacitor, C_c , which blocks the DC polarization voltage. Fig.2.3 shows the simplified equivalent circuit of the condenser microphone and preamplifier. The stray capacitance, C_s is small and may be considered as an integral part of C_t , $C_c \gg C_i$, and is therefore neglected in the simplification. It can be shown that the output voltage, $v(t)$ is given by:

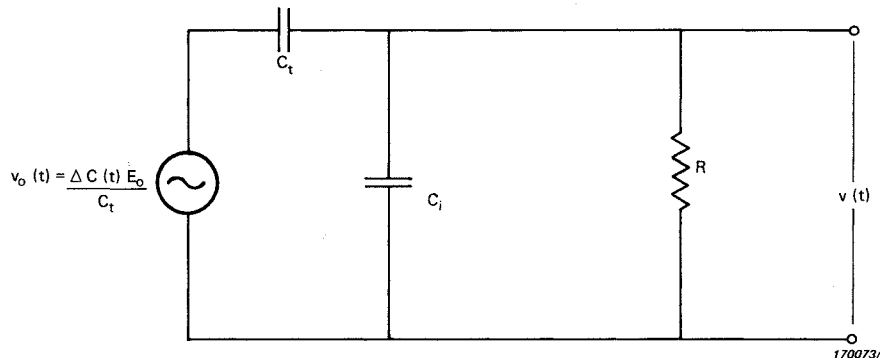

Fig.2.3. Simplified equivalent circuit of a condenser microphone and microphone preamplifier

$$\text{where: } R = \frac{R_c R_i}{R_c + R_i}$$

$$v(t) = \frac{\Delta C(t) \cdot E_0}{C_t} \cdot \frac{C_t}{C} \cdot \frac{j\omega RC}{1 + j\omega RC} = \frac{\Delta C(t) \cdot E_0}{C_t} \cdot \frac{j\omega RC_t}{1 + j\omega RC} \quad (2.3)$$

where $C = C_t + C_i$

So the sensitivity, S is given by:

$$S = \frac{v(t)}{\Delta p(t)} = \frac{\Delta C(t) \cdot E_0}{C_t \cdot \Delta p(t)} \cdot \frac{j\omega RC_t}{1 + j\omega RC} \quad (2.4)$$

where $\Delta p(t)$ = sound pressure variation with time,
and $\Delta p(t) = K_1 \Delta C(t)$ where K_1 is a constant

So

$$S = K_2 \cdot \frac{E_0}{C_t} \cdot \frac{j\omega RC_t}{1 + j\omega RC} \text{ where } K_2 \text{ is a constant} \quad (2.5)$$

From the expression for the microphone sensitivity, S, (Equation 2.5), two basic cases can be considered. First, the high frequency response, when $\omega RC \gg 1$. In this case:

$$S = K_2 \cdot \frac{E_0}{C} \quad (2.6)$$

It is seen that the sensitivity is proportional to the polarization voltage but inversely proportional to the total capacitance C. Any capacitance additional to the transducer capacitance, such as that of the preamplifier, would load the transducer and decrease the overall sensitivity. This means that the total capacitance in the circuit should not greatly exceed the capacitance of the transducer, hence the usual close proximity of the cartridge and its associated preamplifier.

The second case is at low frequencies, when $\omega RC \ll 1$, thus giving

$$S = K_2 \cdot \frac{E_0}{C_t} \cdot j\omega RC_t \quad (2.7)$$

This expression is frequency dependent, and associated with the transition to frequency dependence of sensitivity a cut-off frequency (f_c) can be defined when $\omega RC = 1$ and the sensitivity is reduced by 3 dB. For this case:

$$f_c = \frac{1}{2\pi RC} \quad (2.8)$$

Hence, for a very low lower frequency limit, the input resistance of the preamplifier must be very large. With preamplifiers such as the preamplifiers discussed in this book, this lower frequency limit is of the order of 2 Hz. If lower frequency measurements are required, the Microphone Carrier System Type 2631 is recommended in place of the conventional preamplifiers. The 2631 is fully discussed in its own Instruction Manual.

3. MICROPHONE AND PREAMPLIFIER SELECTION

3.1. MICROPHONE SELECTION

The design of a microphone necessarily involves a compromise of many factors. It is therefore impossible to select a microphone which is suitable for all measurement purposes. In practice, it is necessary to select from the most significant features of the microphone, such as linearity of high frequency pressure response, linearity of high frequency free-field response, linearity of high frequency random incidence response, extended low frequency response, omnidirectivity, dynamic range, as well as any environmental requirements of the measurement location. The condenser microphone provides the most satisfactory combination of all these acoustical characteristics when the problem of precision measurements is considered, and combined with its high long-term stability and its compact dimensions it is generally accepted as the best microphone type for measurements. This section attempts to provide a guide to the selection of a measuring microphone from the wide range of B & K microphones. All details will be found in other sections of this book and the characteristics given here are necessarily summarized.

The main characteristics of the B & K Condenser Microphones are listed in Table 3.1. In general, there is an initial preference for a half-inch microphone for several reasons:

- a) The choice of sensitivities and frequency ranges allow a wide range of requirements to be covered.
- b) The directional characteristics of the half-inch microphone are more uniform within the audio frequency range than those of the one-inch microphones, allowing accurate measurements to be made even in an ill-defined sound field.

Microphone Type	Diameter	Nominal Polarization Voltage	0° Incidence Free Field Response ± 2 dB (Hz)	Typical Random Incidence Response ± 3 dB (Hz)	Pressure Response ± 2 dB (Hz)	Nominal Sensitivity		Polarized Capacitance at 250 Hz (pF)
						(mV/Pa)	(dB re 1 V/Pa)	
4144	one-inch	200 V	2,6 – 18 k	2,0 – 10 k	2,6 – 8 k	50	-26	55
4145	one-inch	200 V		(with UA 0055)		50	-26	66
4165	half-inch	200 V	2,6 – 20 k	2,0 – 12 k	2,6 – 9 k	50	-26	19
4166	half-inch	200 V				50	-26	21
4133	half-inch	200 V	4 – 40 k	* 3,0 – 22 k	4 – 20 k	12,5	-38	18
4134	half-inch	200 V					12,5	-38
4147	half-inch	*			0,0065–18 k	1,1·10 ⁻³ pF/Pa		19,5
4148	half-inch	28 V	4 – 16 k			12,5	-38	17
4149	half-inch	200 V	4 – 40 k			12,5	-38	18
4135	quarter-inch	200 V	4 – 100 k	3,0 – 45 k		4	-48	6,4
4136	quarter-inch	200 V			4 – 70 k	1,6	-56	6,4
4138	eighth-inch	200 V		5,0 – 100 k	6,5 – 140 k	1,0	-60	3,5

* Intended for use with Microphone Carrier System 2631

Table 3.1. Comparison of the principal characteristics of B & K Condenser Microphones

c) It is, in practice, the most reliable of the range.

From this point, check if any national standards (such as ANSI) or international standards (such as IEC, ISO) apply to the measurement. If not, take a free-field response microphone for measurements in open measurement sites and a pressure response microphone for coupler measurements or for measurements in a diffuse sound field. Note that the diffuse field (random incidence) response of the one-inch diameter free-field microphone can be improved by fitting a Random Incidence Corrector UA 0055 (see section 9.6).

If low level measurements are required, then choose in preference a one-inch microphone or a half-inch cartridge Type 4165 or 4166. Note, however, that the noise floor of the 4165 with preamplifier is higher than for one-inch microphones. If high level or high frequency measurements are required, choose a quarter-inch microphone. For very high frequencies, or where very small microphone size is necessary, the eighth-inch microphone can be used.

If any special environmental problems are involved, such as permanent exposure to moisture in an outdoor monitoring situation, the half-inch Type 4149 becomes an automatic choice. The 4149 should always be used in connection with a Dehumidifier or as part of the Outdoor Microphone Unit Type 4921. For intermittent long-term outdoor use (periods of hour rather than day durations) or indoor use under humid conditions, the half-inch rear-vented Types 4165 or 4166 may be used with Dehumidifier UA 0308 (see section 9.7).

Other environmental problems could occur in explosive or highly ionised media, where a 200V polarization would not be acceptable. In such cases, two standard possibilities exist: a low DC polarization voltage may be used with the 4148 (nominally 28 V DC, max. 120V DC) and a low AC voltage (< 10 V), 10 MHz, when the Carrier System 2631 is

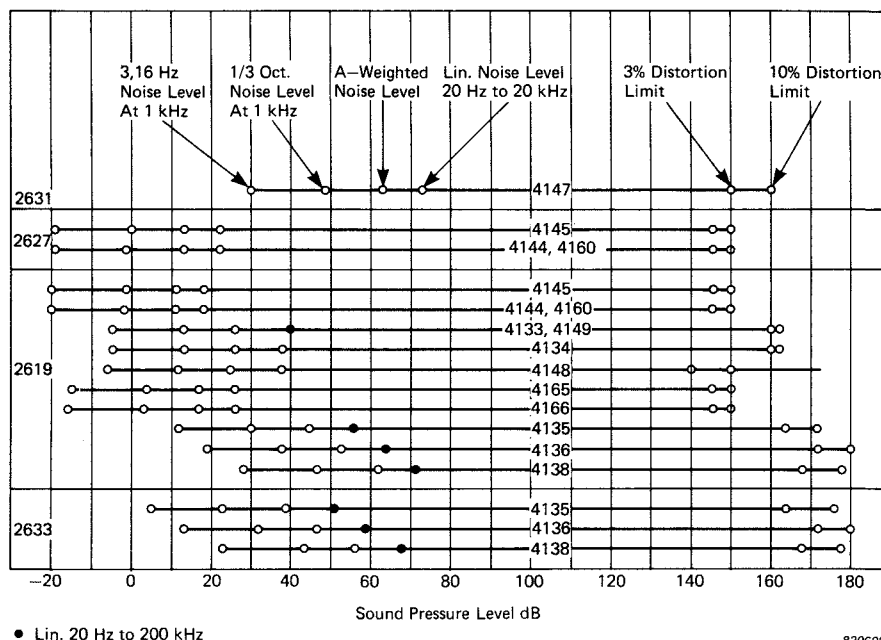

Fig.3.1. Comparison of the dynamic ranges of all the B & K Microphone Preamplifiers fitted with different Condenser Microphones. For description of Type 2631 Carrier Frequency System, see separate literature. The upper limits are indicated for two degrees of distortion, while the lower limits are given for various bandwidths of the measuring equipment. The limits for 3,16 Hz and 1/3 octave bandwidth are valid at 1 kHz only

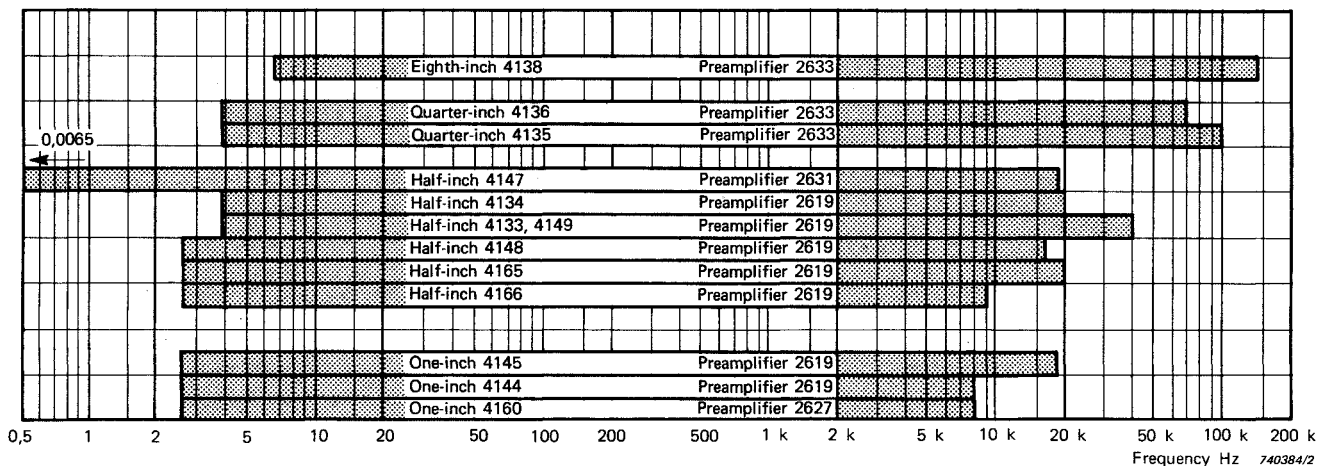

Fig.3.2: Comparison of the frequency response ranges (± 2 dB) of recommended microphone and microphone preamplifier combinations

used with one-inch or half-inch microphones. Since the sensitivity is proportional to the applied polarization voltage (Chapter 2), a microphone may be operated using a reduced polarization voltage if the corresponding reduction in sensitivity and a small change in the frequency characteristics are acceptable.

Comparisons of the dynamic ranges and frequency response ranges for the recommended microphone and preamplifier combinations are given in Figs.3.1 and 3.2 respectively. In both cases, the lower limit of the range is generally determined by the preamplifier characteristic while the upper limit of the range is determined either by the microphone or by the preamplifier.

3.2. PREAMPLIFIER SELECTION

A complete microphone consists of a microphone cartridge and a preamplifier for impedance conversion, permitting the use of long cables and measuring instruments with a relatively low input impedance. The microphone preamplifiers are designed according to two different principles:

- Preamplifiers providing DC polarization voltage
- Preamplifiers using a carrier system

Principal characteristics of the B & K microphone preamplifiers are shown in Table 3.2.

It will be found for general purpose measurements that the selection of the preamplifier follows from the microphone chosen, but the full range of possibilities is shown in Table 3.3. Special cases arise where it is required to perform Insert Voltage calibration of the microphone (see section 4.3.4) when the 2627 will be preferred. For very low frequency measurements, the 2631 becomes the only possibility below 2 Hz. For very low level measurements, the low noise of the 2627 preamplifier is often decisive.

The half-inch Preamplifier Type 2619 can be operated without its heater to give a cold-operating system, although for outdoor measurements it is always recommended that the heater be used.

The 2619 can be delivered as 2619 S in a mahogany box with various accessories or as 2619 T without accessories. See section 8.1.3.

Preamplifier Type No.	2633		2619		2627	2631
	120 V Supply Voltage	28 V Supply Voltage	120 V Supply Voltage	28 V Supply Voltage		
Input impedance (GΩ)	> 50	10**	> 10	> 7	> 10	
Input parallel capacitance C _i (pF)	< 0,25	0,4**	< 0,8	< 1	< 0,5	
Lower frequency limit (-2 dB) electrical One-inch microphone 60 pF (Hz)			< 0,8	< 1	< 0,3	DC
Lower frequency limit (-2 dB) electrical Half-inch microphone 18 pF (Hz)			< 1	< 2		DC
Lower frequency limit (-2 dB) electrical Quarter-inch microphone 6,4 pF (Hz)	< 2	< 2	< 2	< 3		
Lower frequency limit (-2 dB) electrical Eighth-inch microphone 3,5 pF (Hz)	< 2	< 2	< 4	< 6		
Upper frequency limit (-2 dB) electrical (kHz)	> 200	> 200	> 200	> 200	> 200	> 150
Maximum sinusoidal output voltage (V RMS)	32	7	32	4	32	7
Maximum output current (mA peak)	1,4	0,25**	1,5	0,5	1,4	10
Typical preamplifier gain, g (dB)	-0,04	-0,1	-0,03	-0,1	-0,08	variable 1,2-6 V/pF
Output impedance (Ω)	< 100	600**	< 25	< 70	< 50	< 10
Noise Floor (dummy microphone) equivalent sound level in dB One-inch microphone (50 mV/Pa)			20 (lin) 6 (A)		23 (lin) 10 (A)	
Noise Floor (dummy microphone) equivalent sound level in dB Half-inch microphone (50 mV/Pa)			28 (lin) 13 (A)			
Noise Floor (dummy microphone) equivalent sound level in dB Half-inch microphone (12,5 mV/Pa)			40 (lin) 25 (A)			74 (lin) 64 (A) *
Noise Floor (dummy microphone) equivalent sound level in dB Quarter-inch microphone 4135 (4 mV/Pa)	51 (lin) 39 (A)	51 (lin)** 39(A)**	56 (lin) 45 (A)			
Noise Floor (dummy microphone) equivalent sound level in dB Quarter-inch microphone 4136 (1,6 mV/Pa)	59 (lin) 47 (A)	59 (lin)** 47(A)**	64 (lin) 53 (A)			
Noise Floor (dummy microphone) equivalent sound level in dB Eighth-inch microphone (1,0 mV/Pa)	68 (lin) 56(A)	68(lin)** 56(A)**	71 (lin) 62 (A)			
Temperature Range (°C)	- 20 to + 60 ***		- 20 to + 60		- 10 to + 60	- 20 to + 60
Notes					(1)	(2)

(1) Insert voltage calibration capability
(2) Carrier System

* Half-inch microphone 4147 (1,1 x 10⁻³ pF/Pa)
** Typical value
*** up to + 100°C with reduced specifications

740774/2

Table 3.2. Comparison of the principal characteristics of B & K Microphone Preamplifiers

		Preamplifiers			
		One-inch		Half-inch	Quarter-inch
		2631	2627	2619	2633
One-inch	4144 4145	(none) (none)	none none	DB 0375* DB 0375*	
Half-inch	4133 4134 4147 4148 4149 4165, 4166	(UA 0271) (UA 0271) UA 0271 (UA 0271) (UA 0271) (UA 0271)	(UA 0030) (UA 0030) (UA 0030) (UA 0030) (UA 0030)	none none (none) none** none none	
Quarter-inch	4135 4136			(UA 0035) (UA 0035)	none none
Eighth-inch	4138			(UA 0036)	UA 0160

* DB 0375 is provided with 2619S

740769/2

** Must only be used with polarization voltage < 120 V (nominally 28 V)

Table 3.3. Adaptors required for fitting microphones onto microphone preamplifiers. A blank space in the table implies that the combination is not recommended. Parentheses indicate that a more suitable alternative exists

3.3. MICROPHONE POWER SUPPLIES

Microphone Power Supplies are intended for use with a condenser microphone and preamplifier in applications where a measuring amplifier or analyzer with built-in power supply is either not available or not necessary. The microphone power supply provides the necessary voltages to power the preamplifier and the DC polarization voltage for the microphone. A low impedance output permits the use of long cables between the power supply and measuring equipment. The main features of the units available are summarized below. Full details can be found in the respective Product Data and Instruction Manuals.

Type 2804

Two channels, battery operation
Provides either 200 V or 28 V polarization
Cross-switching between channels
Power output sufficient for the 2619 Preamplifier when operated without heater coil and for Type 2633

Type 2807

Two channels, mains operation
Provides 200 V polarization
Manual or automatic switching (chopper) between channels
Channel attenuation adjustable

Type 2811

Eight channels, mains operation
Provides 0 V, 28 V or 200 V polarization
Manual, automatic or external channel selection

4. OPERATION

4.1. PRELIMINARY CONSIDERATIONS

B & K Condenser Microphones are supplied in mahogany cases containing the Microphone and its individual calibration chart. In the mahogany cases of the quarter-inch and eighth-inch microphones, provision is made for storage of one preamplifier adaptor (not provided). In these cases, the quarter-inch and eighth-inch microphones are screwed to a small mounting stud which is fixed to the case (see Fig.4.1).

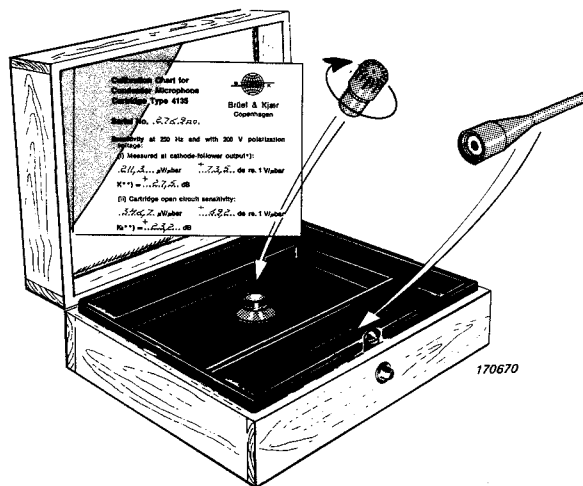

Fig.4.1. The mahogany cases of the quarter-inch and eighth-inch microphones

The following general considerations should be observed before starting measurements:

1. When attaching the microphone to the preamplifier or the protection grid to the cartridge, use finger torque only to tighten the threads.
2. Keep dust and foreign objects away from the diaphragm. In general the microphone should be kept in its case when not in use.
3. Do not forget to remove the silica gel cap from a one-inch microphone before measurement. Note that this cap is fitted over the protection grid of the 4144 and 4145 microphones.
4. Fit the right accessory (windscreens, nose cone, rain cover, random incidence corrector, etc.) according to the particular environmental conditions (see chapter 9).

Note: The microphone diaphragm should not come into contact with fingers or other objects. The protection grid should only be removed when absolutely necessary. Should the diaphragm become contaminated with liquid, dust or oil, it may be carefully cleaned

with cotton wool or a very soft paint brush. The diaphragm will not normally corrode. If the diaphragm becomes slightly contaminated the influence on the frequency response will normally be negligible.

4.2. MOUNTING THE MICROPHONE AND PREAMPLIFIER

Normally the mounting of the microphone and preamplifier is not critical, small, relatively slow movements not causing any problems. The main consideration is that the mounting should not introduce any unwanted signal due to, for example, wind noise (Section 9.2), vibration (Section 8.9) or reflections. When a steady floor stand is appropriate, a rigid tripod is recommended, such as the UA 0587 Tripod.

4.3. FIELD CALIBRATION

The most important characteristics of the microphone are individually calibrated at the factory and are given on the calibration chart supplied inside the lid of the microphone case. Because of this individual calibration and the stability of the microphone and preamplifier when they are carefully handled, field calibration is necessary only to correct short-term drift of the measuring instrumentation. However, it is reassuring, and it is often simpler, to carry out a complete system calibration using a reference sound source applied to the microphone, adjusting amplifier gains to give an appropriate meter deflection or recorder pen indication. The simple procedures involved are described in the following sections.

4.3.1. Pistonphone Type 4220

The Pistonphone Type 4220, shown in Fig.4.2., is a portable battery-driven calibrator designed for field or laboratory calibration of sound measuring equipment. The basic design provides a coupler which accommodates the one-inch microphones, and adaptors are



Fig.4.2. Pistonphone Type 4220

provided to accommodate half-inch, quarter-inch and eighth-inch microphones. The microphone should always be fitted with its standard protection grid when used with the Pistonphone, and in this configuration the sound pressure level at the microphone diaphragm when the microphone is properly seated in the coupler is nominally 124 dB re 20 μ Pa at 250 Hz. Because the free-field correction at this frequency is very small, the Pistonphone may be used to obtain both free-field and pressure calibration. The exact sound pressure in the calibrator is given on an individual calibration chart provided with the Pistonphone and this is accurate to $\pm 0,15$ dB. The calibration is subject to a correction for atmospheric pressure which is given by a barometer provided with the Pistonphone. For further details, see the Instruction Manual for the 4220.

4.3.2. Sound Level Calibrator Type 4230



Fig.4.3. Sound Level Calibrator Type 4230

The Sound Level Calibrator Type 4230, shown in Fig.4.3, is a relatively low priced, miniature, portable, battery operated calibrator designed for field calibration. It operates at a frequency of 1 kHz, and is therefore independent of any frequency weighting network which may be selected on the indicating instrument. The calibration level is 94 dB re 20 μ Pa. The calibration is a pressure calibration and a small correction is therefore required for free-field calibration. The accuracy of the calibration is $\pm 0,3$ dB at $23^{\circ}\text{C} \pm 3^{\circ}\text{C}$ and it remains with $\pm 0,5$ dB over the temperature range 0°C to 50°C . For further details, see the Instruction Manual for the 4230.

Note: For highest accuracy, reference should be made to the individual frequency response curve of the microphone and any difference in sensitivity at 1 kHz and 250 Hz should be taken into consideration.

4.3.3. Measuring Amplifier Reference Voltage — Microphone K-Factor

The B & K measuring amplifiers and analyzers have a built-in reference voltage, which is usually 50 mV at 1 kHz. This reference voltage can be used to calibrate the measuring system after the preamplifier, assuming accuracy of the microphone open circuit sensitivity and nominal gain of the preamplifier which generally is quite justified. The sensitivity of the microphone and preamplifier combination is given by:

$$S_{MP} = S_0 + g + 20 \log_{10} \left(\frac{C_t}{C_t + C_i} \right) \text{ dB re 1 V per Pa} \quad (4.1)$$

where: S_0 = microphone open circuit sensitivity (dB re 1 V per Pa)
 g = preamplifier gain (dB)
 C_t = microphone capacitance (pF)
 C_i = preamplifier capacitance (pF)

Values of S_0 and C_t are given on the microphone calibration chart. Values of g and C_i are given with sufficient accuracy for general purpose use in Table 3.2.

In practice, use of equation 4.1 is made simpler by information on the microphone calibration chart (Fig.4.4). The calibration chart gives a correction factor K_0 which is the dB difference between a reference sensitivity of -26 dB re 1 V/Pa (50 mV) and the microphone open circuit sensitivity.

$$K_0 = -26 - S_0 \text{ dB} \quad (4.2)$$

Typical overall gain of the preamplifier in use is given on the back of the microphone calibration chart. The figure given on the back of the calibration chart, G , includes the effect of microphone and preamplifier capacitance, so

$$G = g + 20 \log_{10} \left(\frac{C_t}{C_t + C_i} \right) \text{ dB} \quad (4.3)$$

Hence, an overall correction factor K can be defined:

$$K = K_0 - G \text{ dB} \quad (4.4)$$

For example, the open circuit correction factor K_0 is given as $+ 12,3 \text{ dB}$ on the calibration chart of a half-inch microphone Type 4133. When used with Preamplifier Type 2619, the back of the calibration chart gives an overall gain factor G of $-0,2 \text{ dB}$. Therefore, the overall correction factor K is $+ 12,3 - (-0,2 \text{ dB}) = + 12,5 \text{ dB}$.

This is very simply used in practice by first setting up the measuring instrumentation to the reference sensitivity of $-26 \text{ dB re 1 V per Pa}$ and then correcting this by adding K dB to the readings obtained. Alternatively, the measuring instrumentation can be set-up for a microphone sensitivity of $-26 \text{ dB} - K \text{ dB re 1 V per Pa}$.

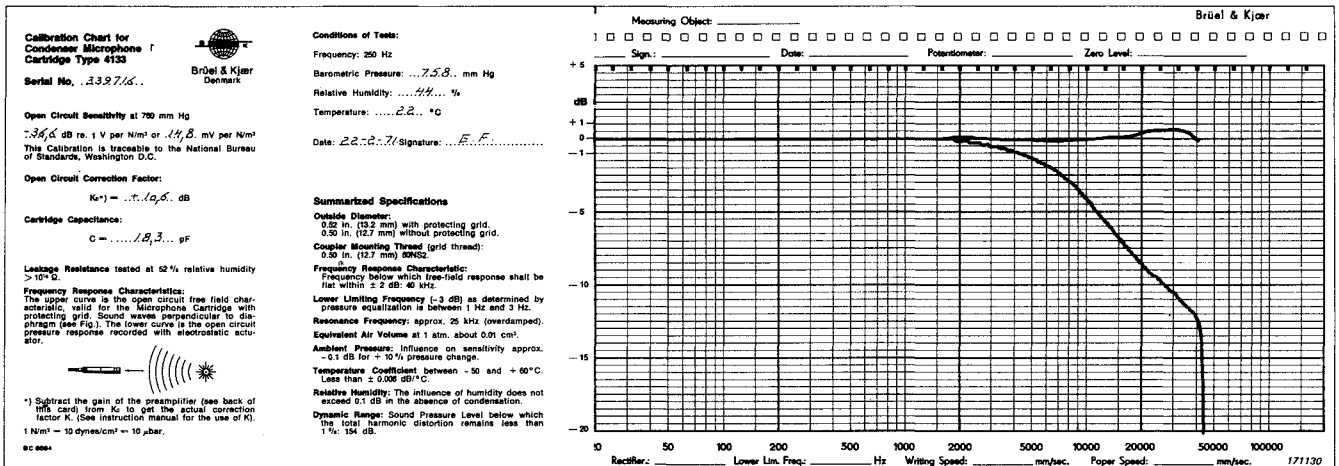

Fig. 4.4. A typical microphone calibration chart

Details of the calibration procedure are given in the relevant Instruction Manual of the measuring amplifier or analyzer.

4.3.4. Insert Voltage Calibration

Insert voltage calibration is a technique which can be used for two purposes:

1. In calibration laboratories, it is used to assess the open circuit sensitivity of microphone cartridges.
2. It can provide a convenient means for checking in the field the electrical sensitivity of a complete sound measuring system, including preamplifier and cables. However, the method does not account for the mechanical parameters which determine the acoustical properties of the microphone cartridge itself.

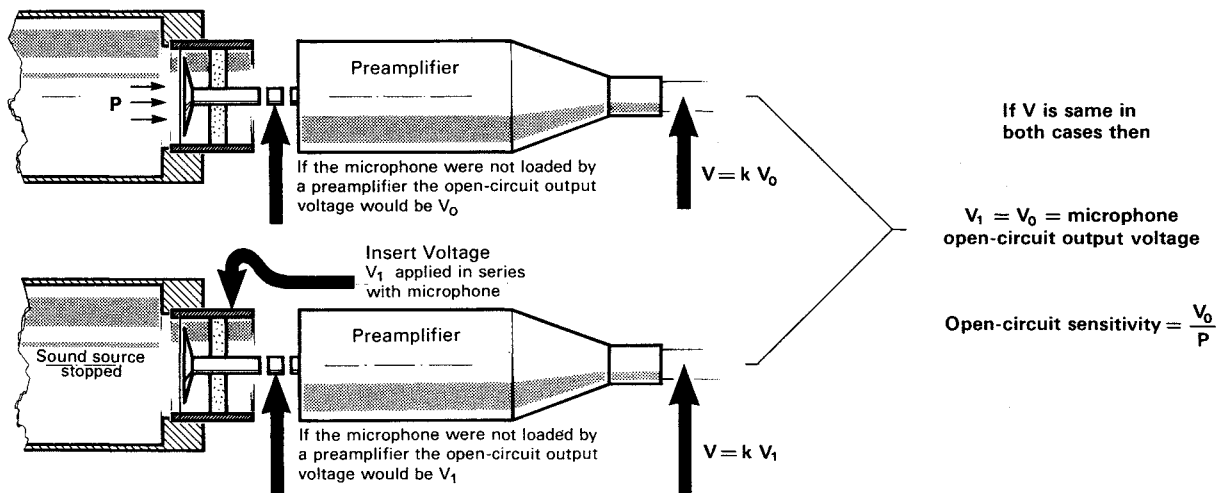

820196

Fig. 4.5. Principle of the Insert Voltage Calibration

The Insert Voltage Preamplifier Type 2627 should be used for this application. In the calibration (Fig.4.5), the microphone is first subjected to a sound pressure of known level and frequency (say 94 dB at 1 kHz from the 4230 Calibrator). This causes the microphone to generate an internal voltage V_0 (corresponding exactly to the open circuit microphone voltage) which, when loaded by the preamplifier, produces an output voltage V at the preamplifier output. The sound source is then switched off and the insert voltage V_1 of the same frequency applied (such as the internal reference voltage of a measuring amplifier). The level of the insert voltage is adjusted so that the voltage measured at the preamplifier output is again V .

Provided this voltage V is noted, when the microphone and preamplifier are used remote from the measuring equipment, or if for other reasons it is convenient to apply a direct sound pressure to the microphone, the insert voltage method can be used to adjust the sensitivity of the equipment. This will provide a system calibration which relies only on the value of V remaining constant.

One advantage of the insert voltage calibration technique is that the preamplifier and (where these are used) line drive insert amplifiers and transmission lines may be checked. Full details of the method are contained in the Instruction Manual of the measuring amplifier or analyzer. (Types 2010 and 2120 have a direct insert voltage calibration facility.)

4.3.5. Electrostatic Actuator

As long as microphone sensitivity remains constant, there is, in practice, no risk of change in frequency characteristics. However, if for any reason field calibration of frequency response of the microphone and preamplifier is required, the only simple method available is the electrostatic actuator. Three versions of the principle are available from the B & K accessories, UA 0023 for one-inch microphones, UA 0033 for half-inch microphones and for smaller microphones fitted with a suitable adaptor, and the Rain Cover UA 0393 for half-inch microphones (the Rain Cover has an integral electrostatic actuator). Details of the calibration method are given in section 7.3 with particular reference to UA 0023 and UA 0033, but the method is equally applicable to UA 0393. However, the electrostatic actuator of the Rain Cover UA 0393 is particularly intended as a single frequency calibrator for a remote outdoor microphone. Although it can be used for relative measurements of frequency response, at high frequencies an acoustical influence due to the Rain Cover introduces non-linearities.

4.4. ACCESSORIES

Table 4.1 lists the various accessories which adapt the condenser microphones to the measuring environment. Use of the accessories is discussed in Chapter 9.

Microphone Type		Foam Windscreen	Permanent Outdoor Windscreen	Rain Cover	Nose Cone	Turbulence Screen	Random Incidence Corrector	Sealing Kit	Electrostatic Actuator	Field Calibrator
One-inch	4144	UA 0207			(UA 0387)			UA 0240	UA 0023	4220 or 4230
	4145	UA 0207			UA 0387		UA 0055	UA 0240	UA 0023	4220 or 4230
Half-inch	4133	UA 0237	UA 0570	UA 0393	UA 0386	UA 0436			UA 0033	4220 or 4230
	4134	UA 0237	UA 0570	UA 0393	(UA 0386)	(UA 0436)			UA 0033	4220 or 4230
	4147	UA 0237	UA 0570	UA 0393	(UA 0386)	(UA 0436)			UA 0033	4220 or 4230
	4148	UA 0237	UA 0570	UA 0393	UA 0386	UA 0436			UA 0033	4220 or 4230
	4149	UA 0237	UA 0570	UA 0393	UA 0386	UA 0436			UA 0033	4220 or 4230
	4165	UA 0237	UA 0570	UA 0393	UA 0386	UA 0436			UA 0033	4220 or 4230
Quarter-inch	4135				UA 0385				UA 0033 + DB 0264	4220
	4136				UA 0385				UA 0033 + DB 0264	4220
Eighth-inch	4138				UA 0355				UA 0033 + DB 0900	4220

740775/2

Table 4.1. Principal sound measurement accessories for use with B & K Condenser Microphones. A blank space in the table indicates that an accessory is either not available or not recommended. Parentheses indicate that a more suitable alternative exists

5. CONSTRUCTION

5.1. PRINCIPLE

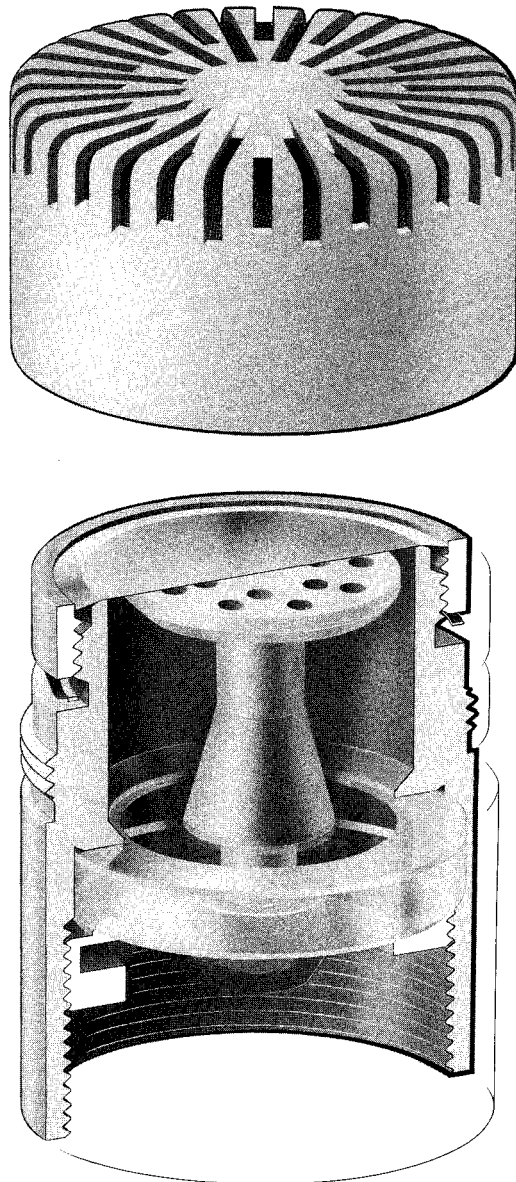

Fig.5.1. Half-inch Condenser Microphone Type 4165

B & K Condenser Microphones have a main body housing of monel, on which a thin (between $1,6 \mu\text{m}$ and $6,5 \mu\text{m}$ depending on type) nickel diaphragm is mounted. The diaphragm is the moving electrode of a parallel plate, air dielectric capacitor. The fixed electrode is a rigid monel backplate mounted inside the monel body on a quartz, synthetic

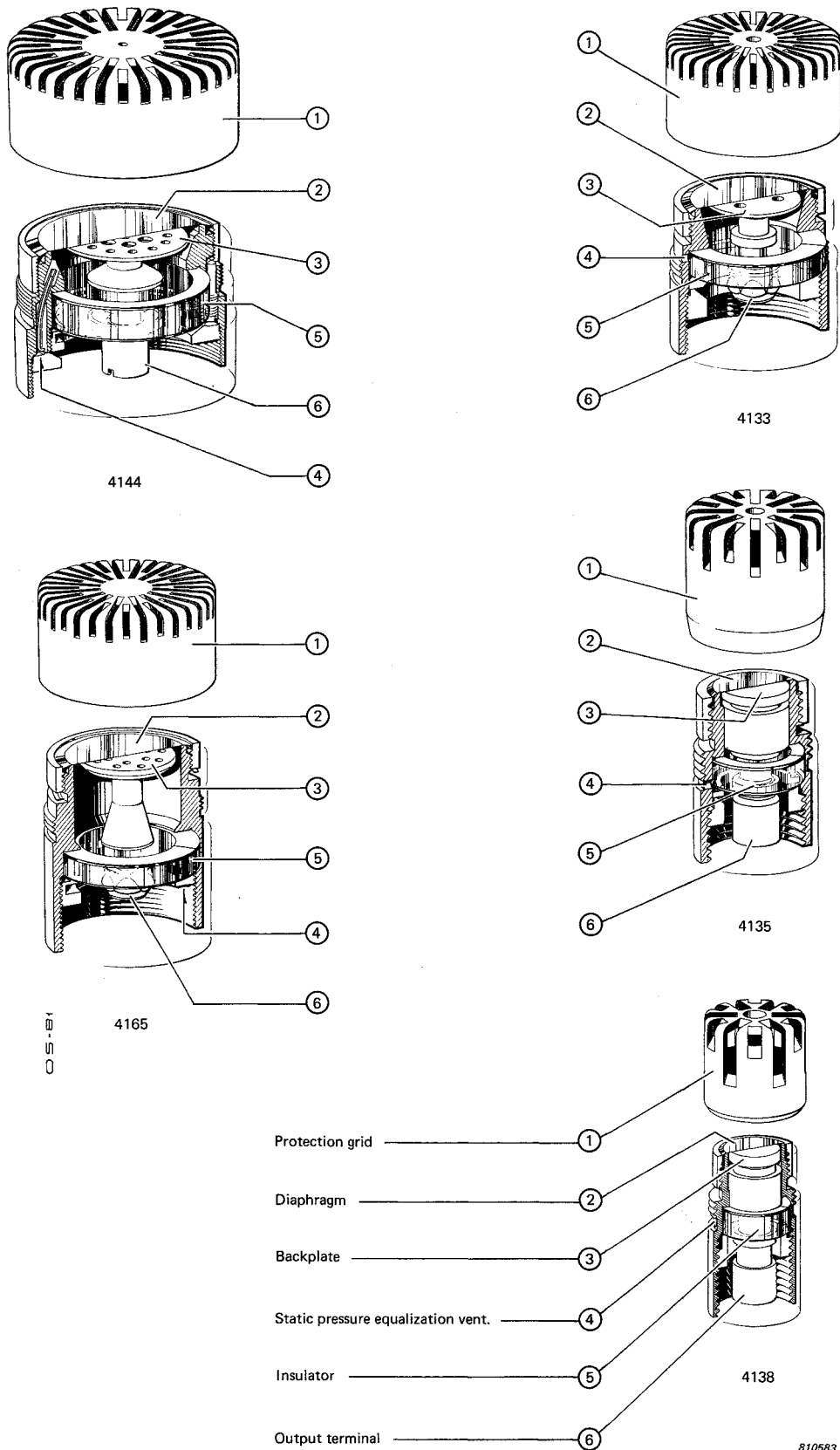

Fig. 5.2. Cut-away views of the one-inch and half-inch microphones
 a) Types 4144, 4145 (one-inch diameter)
 b) Types 4133, 4134, 4149 (half-inch diameter)
 c) Types 4147, 4148, 4165, 4166 (half-inch diameter)
 d) Types 4135, 4136 (quarter-inch diameter)
 e) Type 4138 (eighth-inch diameter)

sapphire or ruby insulator. The housing, insulator and diaphragm form a closed cavity. As a pressure difference is experienced between the inside and outside of the cavity, such as would occur if the microphone were placed in a sound field, the diaphragm will be deflected, causing a capacitance variation which can be measured electrically. The frequency characteristics of the microphone will be determined by the diaphragm movement, principally by its resonance and the damping added to it. The resonance frequency is determined by the mass of the diaphragm and the tension in it. Damping is a function of the air flow in the space between the diaphragm and the backplate, and it may be varied by changing the geometry of the backplate and the distance between diaphragm and backplate (normally 20 μm).

Because changes in atmospheric pressure as a function of time and location far exceed the small pressure variations due to sound, a small equalization tube vents the inner cavity to the atmosphere. The vent is large enough to permit equalization of the low frequency atmospheric variations, but not the sound pressure variations. There will be a resulting lower limiting frequency for the microphone cartridge, which for the more commonly used types is approx. 2 Hz (-3 dB). One type is specially constructed for lower frequency operation.

By careful choice of these mechanical parameters, various microphone types covering a wide range of applications can be made. Choice of materials and extreme care in manufacture make their characteristics stable with time and temperature and define the difference between a measuring microphone and other condenser microphones.

Cut-away drawings of the four main microphone sizes are shown in Fig.5.2.

5.2. DIMENSIONS

Dimensions of the microphone cartridges are shown in Fig.5.3 and Table 5.1.

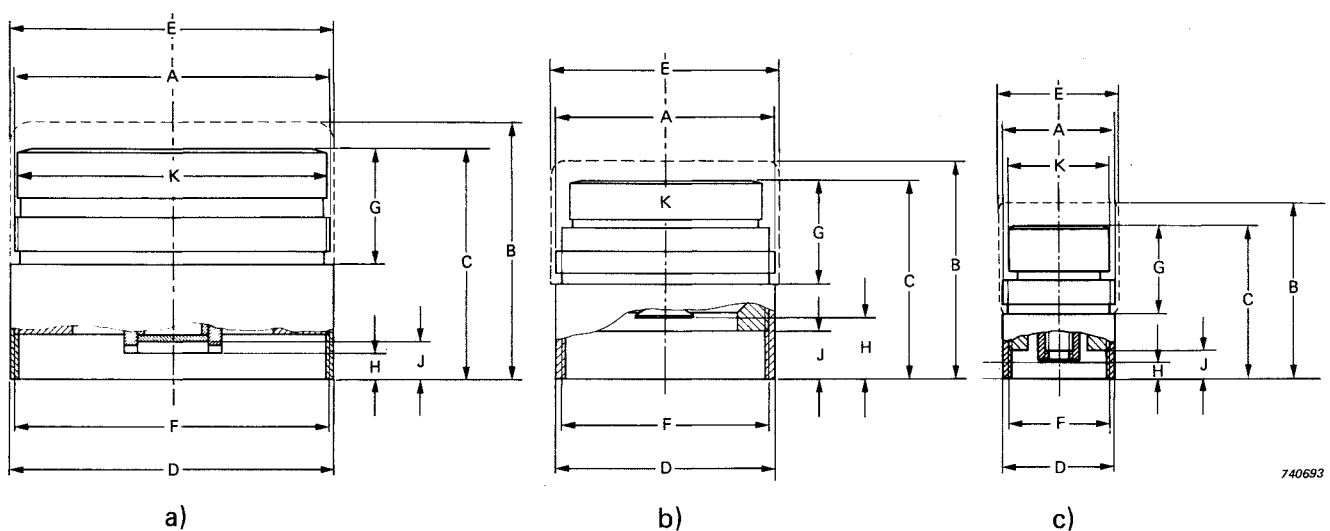

Fig.5.3. Microphone dimensions (see also Table 5.1)
a) One-inch
b) Half-inch
c) Quarter-inch and eighth-inch

Dimension	Microphone Type				
	4144, 4145	4133, 4134, 4149	4147, 4148 4165, 4166	4135, 4136	4138
A	23,11	12,7	12,7	6,35	3,175
thread A	60 UNS-2	60 UNS-2	60 UNS-2	60 UNS-2	M 3,175 x 0,2
B	19	12,6	16,3	10,5	6,7
C	17	11,5	15,2	9	6
D	23,77 ± 0,02	12,7 ± 0,03	12,7 ± 0,03	6,35 ± 0,03	3,175 +0,05; -0
E	23,77 ± 0,02	13,2 ± 0,02	13,2 ± 0,02	7 ± 0,03	3,5
thread F	60 UNS-2	60 UNS-2	60 UNS-2	60 UNS-2	M 3 x 0,25
F	23,11	11,7	11,7	5,7	3
G	8,5	6	6	5	2,75
H	1,5	3,6	3,6	1	0,5
J	3,3	2,8	2,8	1,8	1,75
K	22,70	12,2	12,2	5,95	3,0

740765/2

Table 5.1. Microphone dimensions (see also Fig.5.3)

5.3. PRESSURE EQUALIZATION ARRANGEMENTS

Two alternative static pressure equalization arrangements are available for the half-inch microphones. These are:

- a) Side vented equalization
- b) Back vented equalization

The one-inch, quarter-inch and eighth-inch microphones are side vented.

The microphones are designed for a lower limiting frequency (-3 dB) of around 2 Hz, adjustment on one-inch microphones being made in production by inserting varying diameters of silver wire into the capillary tube of the vent until the required frequency limit is achieved.

Where the microphone is likely to be used in a humid environment (such as in outdoor measurements), it is an advantage to have an equalization vent to the rear of the cartridge. This permits drying of the air supplied to the interior of the microphone (see section 9.7).

For very low frequency measurements, the one-inch microphones Type 4144 and 4145 may be sealed using a special sealing kit UA 0240. Kit UA 0240 can be used for Types 4144 and 4145 but is not suitable for other microphone sizes. The half-inch microphone 4147, which is specially designed for low frequency measurements, has been sealed by special production processes. A controlled vent arrangement determines the lower limiting frequency, which is of the order of 0,005 Hz (-3 dB).

5.4. OUTDOOR MICROPHONE TYPE 4149

For permanent outdoor use, considerable problems arise with humidity and a risk of fungus growth. For such applications, the half-inch diameter Microphone Type 4149 has been developed. It is intended principally for use with the Outdoor Microphone Unit 4921 and the specifications of this Unit should be carefully examined before employing the 4149 out of doors with any other preamplifier.

The 4149 is acoustically similar to the 4133 but is back vented for use with a dehumidifier. Additionally, the diaphragm and back plate are coated with a thin layer of quartz. The quartz layer adds only 4% to the mass of the diaphragm, which has an insignificant effect on the electroacoustic properties.

The quartz layer on the diaphragm effectively seals the porosity of the diaphragm material which would otherwise allow the penetration of moisture in high humidity conditions. Simultaneously, it protects the diaphragm against corrosion.

The quartz layer on the back plate protects the surface against corrosion, while not affecting the electrical characteristics of the condenser microphone.

6. CHARACTERISTICS

Note: The characteristics discussed in this chapter refer particularly to use with a voltage preamplifier (such as the B & K Types 2633, 2619, 2627) and DC polarization. Some modification is required when considering use with the Microphone Carrier System 2631. These details are covered in the separate Instruction Manual for the 2631.

6.1. SENSITIVITY

6.1.1. Open Circuit Sensitivity

The open circuit sensitivity is the sensitivity of the microphone cartridge when it is not loaded by a preamplifier. This sensitivity is measured for the individual cartridge at 250 Hz with 200 V polarization (or 28 V polarization for the 4147 and 4148) and is given on the individual calibration chart, an example of which is shown in Fig.4.4. The nominal open circuit sensitivities and accepted deviations from these values are shown in Table 6.1.

Microphone Type		Nominal Open Circuit Sensitivity		Accepted Deviation (dB)
		mV/Pa	dB re 1V/Pa	
One-Inch	4144, 4145	50	-26	± 1,5
Half-Inch	4133, 4134, 4149	12,5	-38	± 2
	4165, 4166	50	-26	± 1
	4147	1,1 × 10 ⁻³ pF/Pa*		± 1,5
	4148	12,5	-38	± 1,5
Quarter-Inch	4135	4	-48	± 3
	4136	1,6	-56	
Eighth-Inch	4138	1,0	-60	

* In use with Microphone Carrier System Type 2631

810073

Table 6.1. Nominal open circuit sensitivity of the microphones

6.1.2. Loaded Sensitivity

When the microphone is loaded by the capacitance of the preamplifier, the overall sensitivity of the microphone and preamplifier is given by:

$$S_{MP} = S_o \cdot g \cdot \frac{C_t}{C_t + C_i} \quad (6.1)$$

where S_{MP} = overall sensitivity of microphone and preamplifier (mV/Pa)
 S_o = open circuit sensitivity of microphone (mV/Pa)
 g = voltage gain of preamplifier
 C_t = microphone cartridge capacitance (pF)
 C_i = input capacitance of preamplifier (pF)

Further practical details are given in section 4.3.3.

6.2. FREQUENCY RESPONSE

6.2.1. Microphone Calibration Chart

The calibration chart provided with each individual microphone (see, for example, Fig.4.4) gives the microphone frequency response measured with an electrostatic actuator (see section 7.3). The basic response curve is a pressure response curve, to which is added, where appropriate, the free-field correction for 0° incidence, and the random incidence correction (See section 6.2.3). In all cases except that of the 4147 microphone, the nominal polarization voltage of the microphone is used, 200 V or 28 V as stated on the calibration chart. For the 4147, however, which is primarily intended for use with the Microphone Carrier System 26341, 28 V polarization is used, since this frequency response is indistinguishable from that of the 2631.

The calibration curve provided extends down to 20 Hz, but it may be assumed that the response is linear down to the approach of the lower limiting frequency as determined by its pressure equalization system (see section 6.2.6). However, in order to obtain the true frequency response of the microphone and preamplifier, the frequency characteristic of the preamplifier must be added to that of the microphone. In most cases the influence of the preamplifier response is negligible, but if measurements below 20 Hz must be performed, or if the preamplifier is to be loaded with a long cable, there may be an influence of some significance.

The preprinted card to which the individual frequency response of the microphone is glued provides other important individual characteristics appropriate to the type and the purpose of the microphone. In addition, more general specifications indicate characteristics of the microphone type which have been verified for the individual cartridge in the factory calibration.

6.2.2. High Frequency Response

The frequency response of the microphone is determined by four main factors:

- a) Diaphragm stiffness
- b) Mechanical damping of the diaphragm due to viscous resistance to air movement between diaphragm and backplate
- c) Diaphragm mass
- d) Interference and diffraction effects at frequencies where the microphone diameter becomes of the same order as the wavelength.

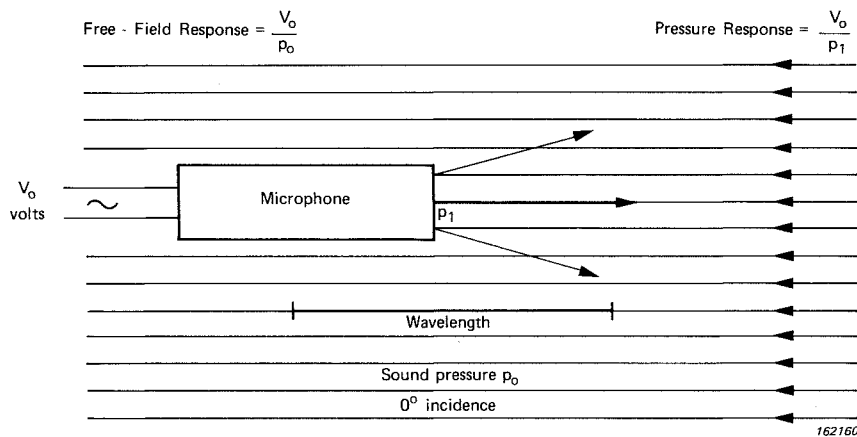

Fig.6.1. Definitions of free-field response and pressure response

The mass and stiffness of the diaphragm are the major components which determine the mechanical resonance frequency of the microphone. Above the resonance frequency, diaphragm motion becomes mass controlled rather than stiffness controlled, and sensitivity decreases for increasing frequency.

Around the resonance frequency, however, the sound pressure at the microphone diaphragm increases due to interference and diffraction effects. The problem can be appreciated from Fig.6.1 which shows a microphone in an otherwise free sound field. Because of the diffraction and interference problem, we can consider two possible sensitivities; first the sensitivity of the microphone to the pressure actually existing at its diaphragm (V_0/p_1 , the Pressure Response), and secondly the sensitivity of the microphone to the pressure which would exist at the diaphragm position in the absence of the microphone (V_0/p_0 , the Free-Field Response). The difference between the two responses in dB is known as the Free-Field Correction of the microphone, and by increasing the internal damping of the microphone around its resonance, it is possible to construct a microphone whose Free-Field Response to sound incident along its axis is independent of frequency to relatively high frequencies. The alternative to this is to construct a microphone whose Pressure Response is linear to the highest possible frequency.

Absolute calibration of the pressure response of a microphone is possible by the reciprocity calibration technique as described in IEC 327. Since this technique is time consuming, the frequency response of B & K microphones in production is tested using the electrostatic actuator technique. This gives a response which is very close to the closed coupler response. Maximum deviations from the pressure response as measured by IEC 327 are about 1 dB around the resonance frequency for the one-inch microphones. This is described in detail in the Brüel & Kjær Technical Review No.2, 1969. However, for smaller microphones, the error is significantly smaller. For example for the half-inch microphone it is about 0,25 dB.

Most free-field corrections given in this manual are thus relative to the electrostatic actuator response given on the microphone's individual calibration chart.

6.2.3. Free-Field Correction Curves to Electrostatic Actuator Pressure Response

The level difference between the pressure actually existing at the microphone diaphragm, p_1 , and the free field sound pressure, p_0 , is referred to as the Free Field Correction of the microphone:

$$\text{Free Field Correction} = 20 \log_{10} \left(\frac{p_1}{p_0} \right) \quad (6.2)$$

The Free Field Correction is a function of frequency, and the various corrections for the B & K microphone types are given in Figs.6.2 to 6.16. The figures give curves for correcting the electrostatic actuator response given on the supplied calibration chart for various angles of sound incidence.

The Random Incidence correction is also given in Figs.6.2 to 6.16. The Random Incidence obtained using these curves characterizes the frequency response of the microphone in a diffuse sound field. It is an averaging of the microphone's response at all angle of incidence. The corrections given are calculated as defined in IEC Publication 651 1979 "Sound Level Meters", Appendix B:

$$S^2 = 0,018 (S_0^2 + S_{180}^2) + 0,129 (S_{30}^2 + S_{150}^2) + 0,244 (S_{60}^2 + S_{120}^2) + 0,258 S_{90}^2 \quad (6.3)$$

where S_0 , S_{30} , S_{60} , S_{90} , S_{120} , S_{150} , S_{180} are microphone sensitivities at the respective angles of incidence (mV/Pa).

The Free-Field Corrections should be added to the pressure response characteristics of the microphone given on the electrostatic actuator chart to give the free-field characteristic for the respective angle of incidence. The corrections are functions of the geometry of the microphones and to a very small degree the acoustical impedance of their diaphragms. Therefore, the corrections are similar for a given microphone type. However, due to the great differences in resonance frequency and diaphragm impedance Types 4165 and 4166 have different corrections.

IEC Publication 655, 1979 "Values for the difference between free-field and pressure sensitivity levels for one-inch standard condenser microphones" specifies values to be added to the microphone pressure sensitivity level when a high degree of accuracy is not required, or when an accurate free-field calibration is not possible. Fig.6.17 illustrates the values given for 0° and 90° incidence for a one-inch microphone type A, as defined in IEC 655, with flush mounted diaphragm used without the normal protection grid. B & K one-inch microphone Type 4145 corresponds to a type A microphone which is defined as follows:

Type A: Microphones characterized by having a nearly constant free-field sensitivity at normal incidence over a broad frequency range, commonly known as free-field type microphones. The resonance of the diaphragm is heavily damped.

(Earlier B & K one-inch microphone Type 4131 also corresponds to a type A microphone.)

Free field corrections for the microphones plus accessories are given in Chapter 9.

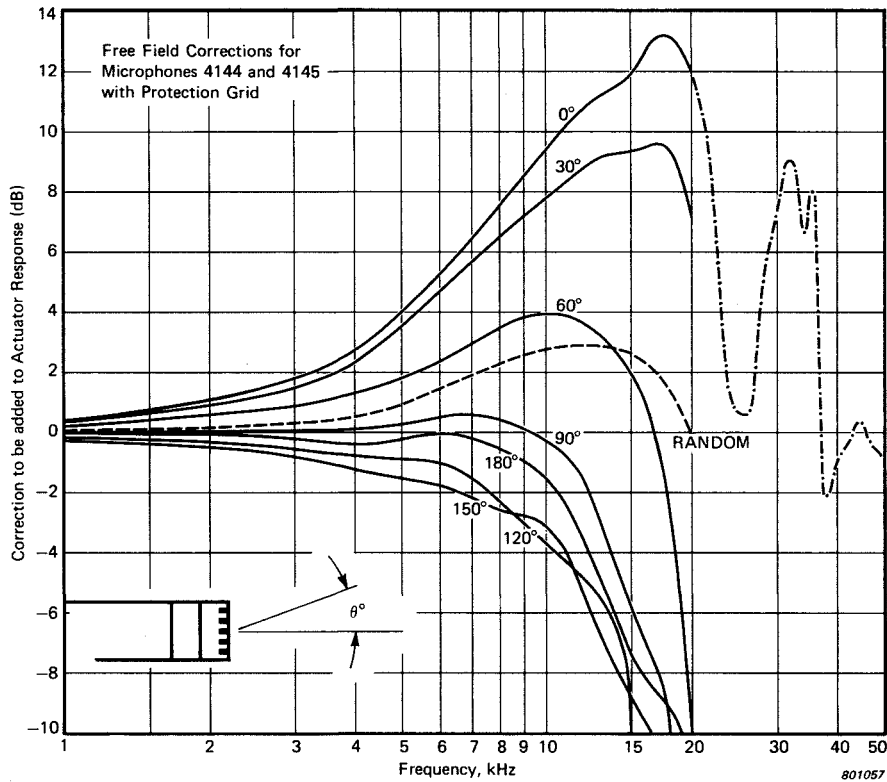

Fig. 6.2. Free-field correction curves for one-inch Condenser Microphones Types 4144 and 4145 fitted with normal protection grid

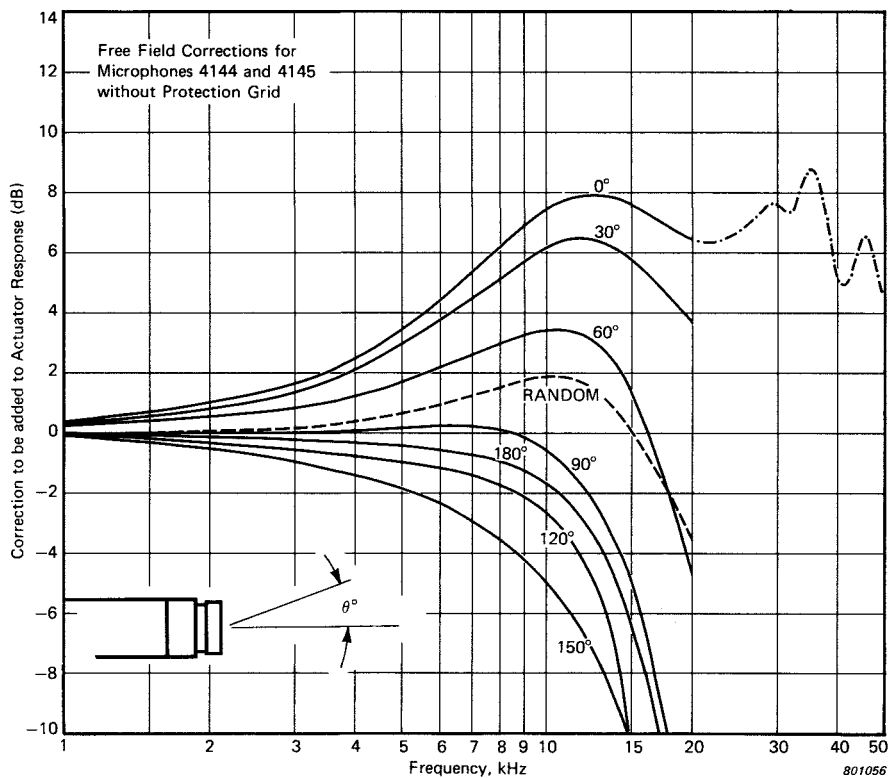

Fig. 6.3. Free-field correction curves for one-inch Condenser Microphones Types 4144 and 4145 without normal protection grid

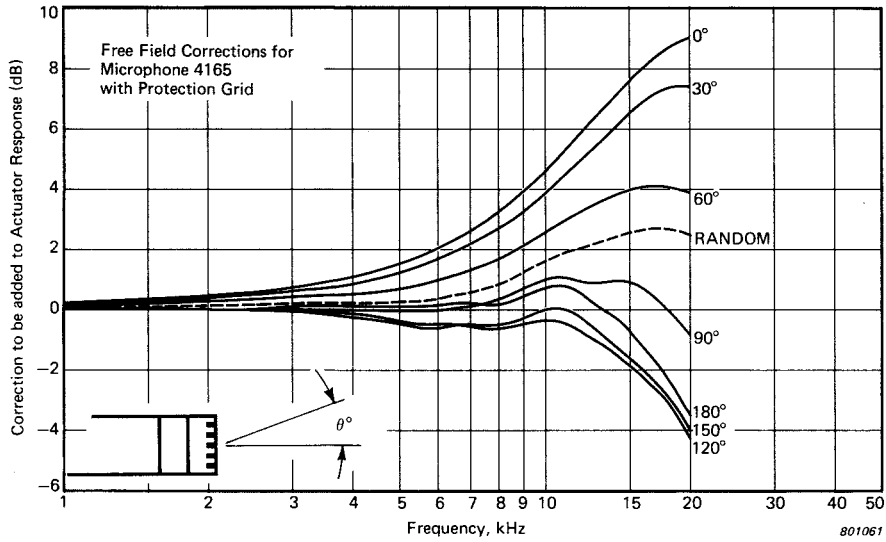

Fig.6.4. Free-field correction curves for half-inch Condenser Microphone Type 4165 fitted with normal protection grid

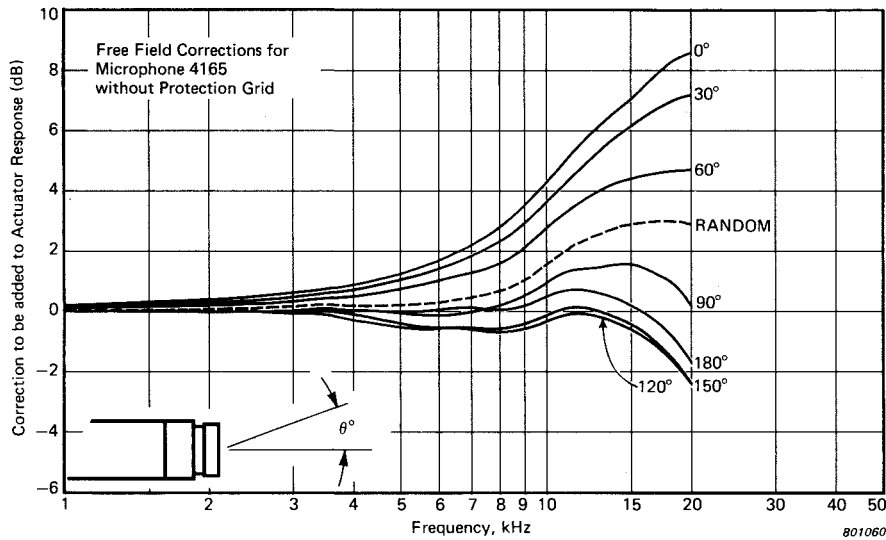

Fig.6.5. Free-field correction curves for half-inch Condenser Microphone Type 4165 without normal protection grid

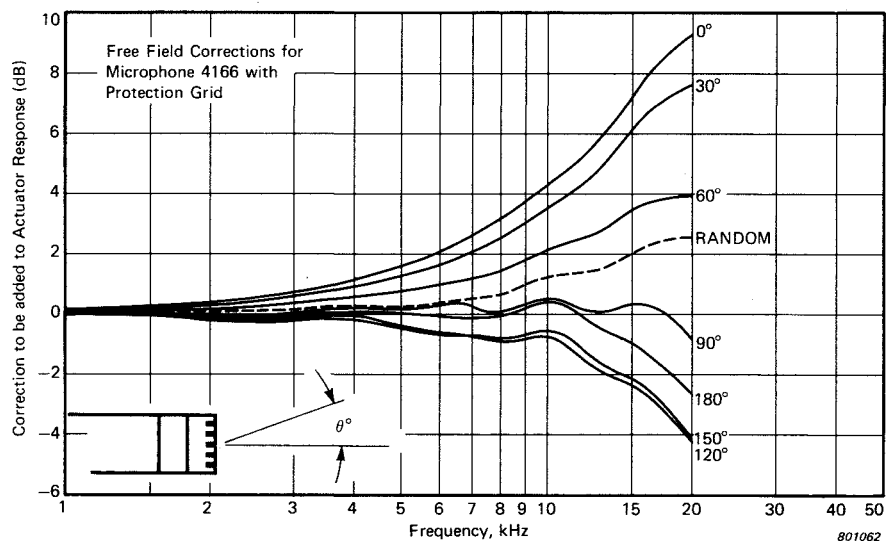

Fig.6.6. Free-field correction curves for half-inch Condenser Microphone Type 4166 fitted with normal protection grid

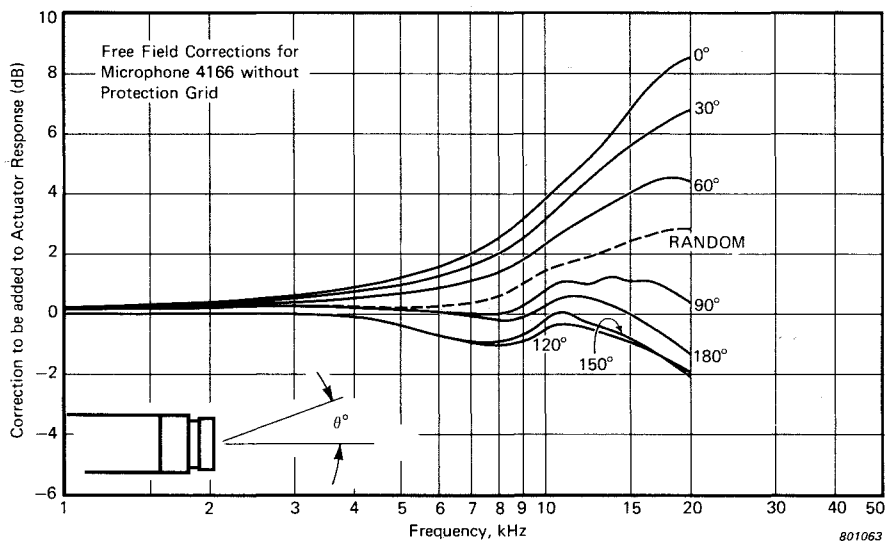

Fig.6.7. Free-field correction curves for half-inch Condenser Microphone Type 4166 without normal protection grid

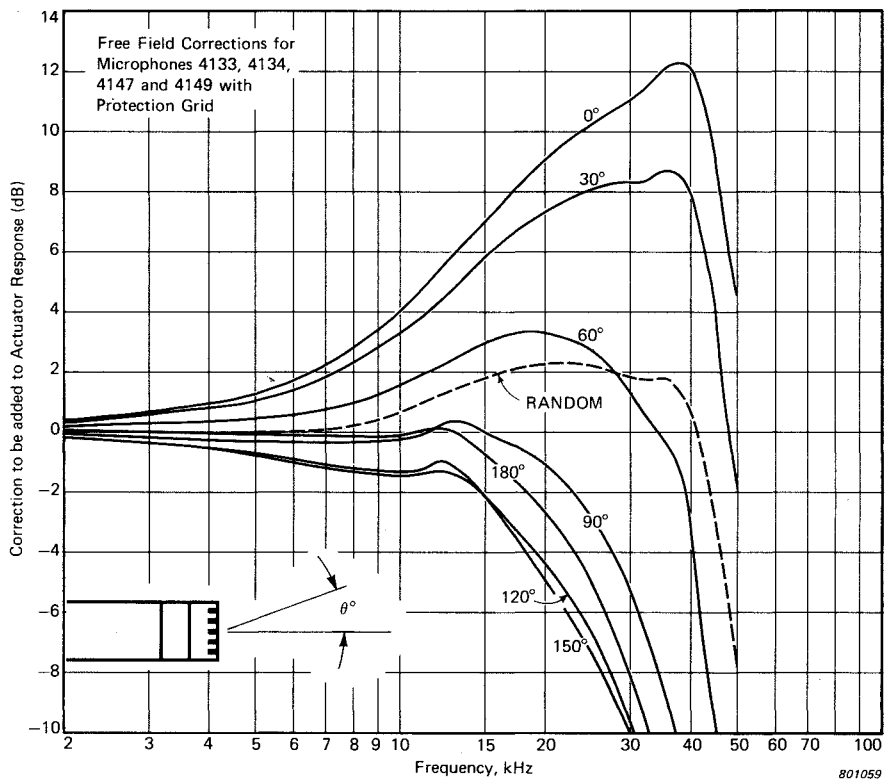

Fig.6.8. Free-field correction curves for half-inch Condenser Microphones Types 4133, 4134, 4147 and 4149 fitted with normal protection grid

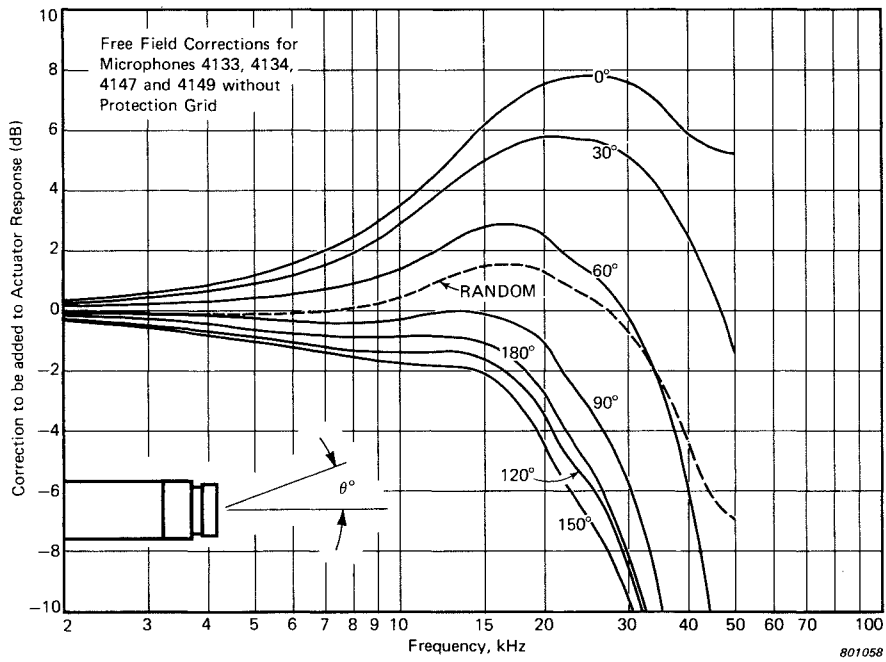

Fig.6.9. Free-field correction curves for half-inch Condenser Microphones Types 4133, 4134, 4147, 4149 without protection grid

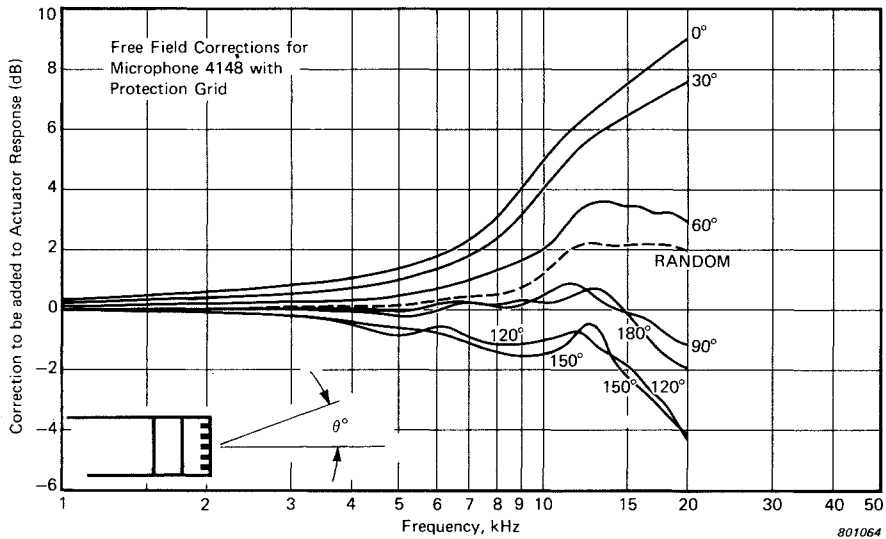

Fig.6.10. Free-field correction curves for half-inch Condenser Microphone Type 4148 fitted with normal protection grid

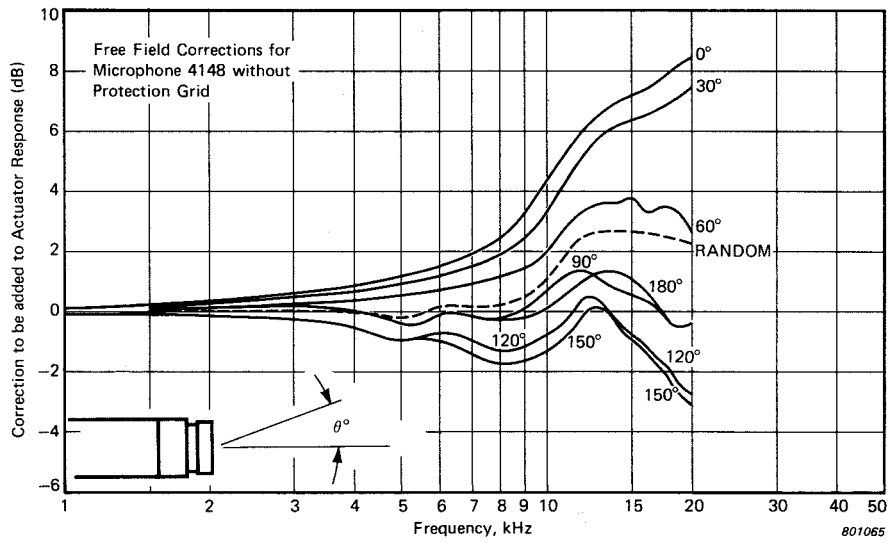

Fig.6.11. Free-field correction curves for half-inch Condenser Microphone Type 4148 without normal protection grid

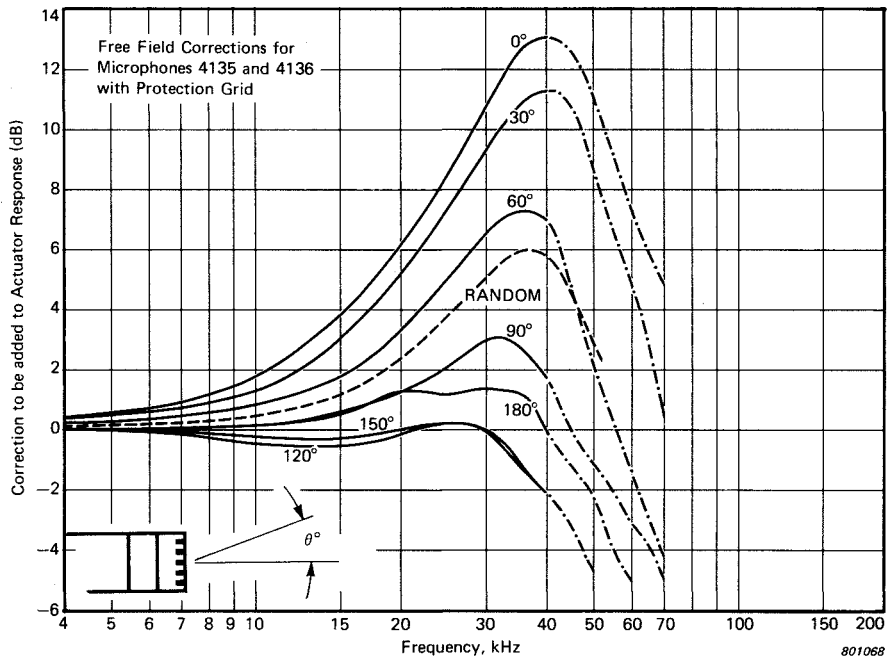

Fig.6.12. Free-field correction curves for quarter-inch Condenser Microphones Types 4135 and 4136 fitted with normal protection grid

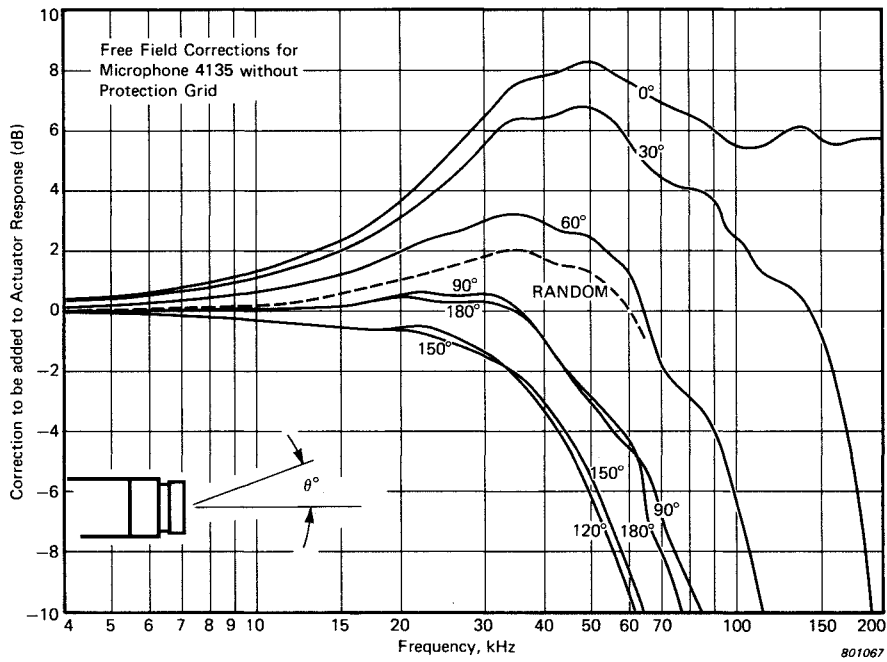

Fig.6.13. Free-field correction curves for quarter-inch Condenser Microphone Type 4135 without normal protection grid

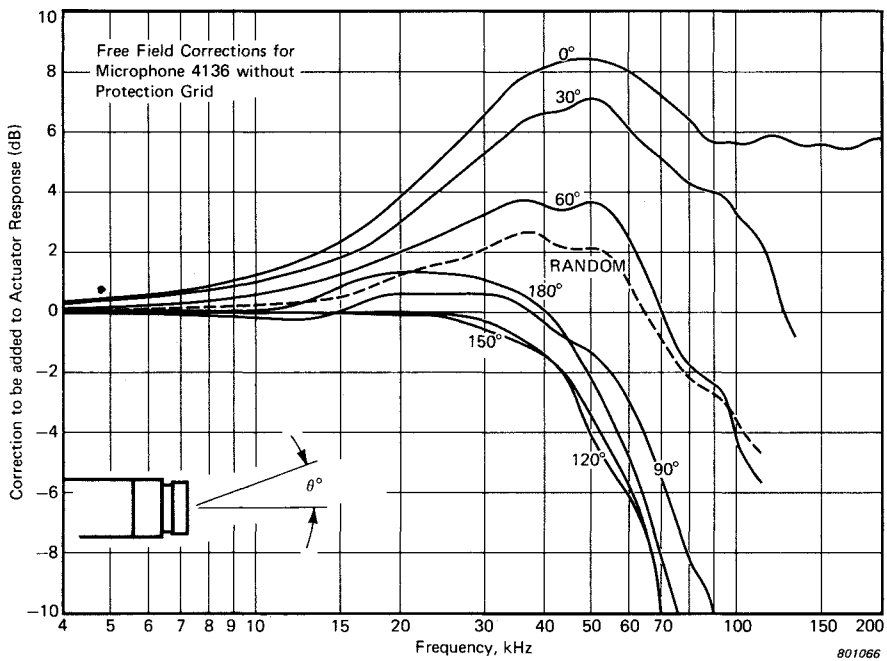

Fig.6.14. Free-field correction curves for quarter-inch Condenser Microphone Type 4136 without normal protection grid

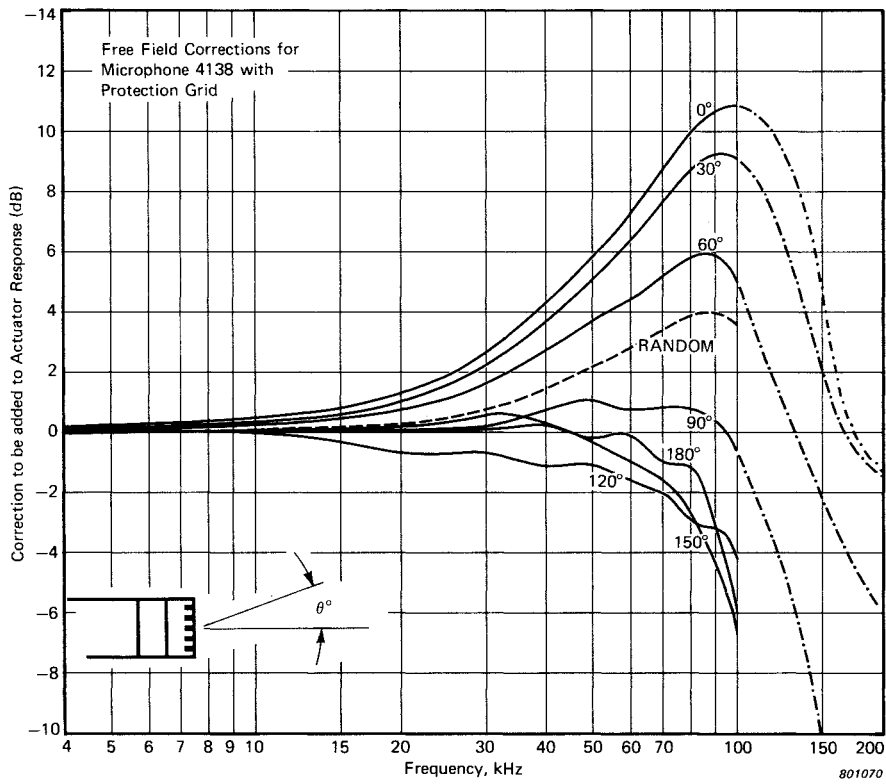

Fig. 6.15. Free-field correction curves for eighth-inch Condenser Microphone Type 4138 fitted with normal protection grid

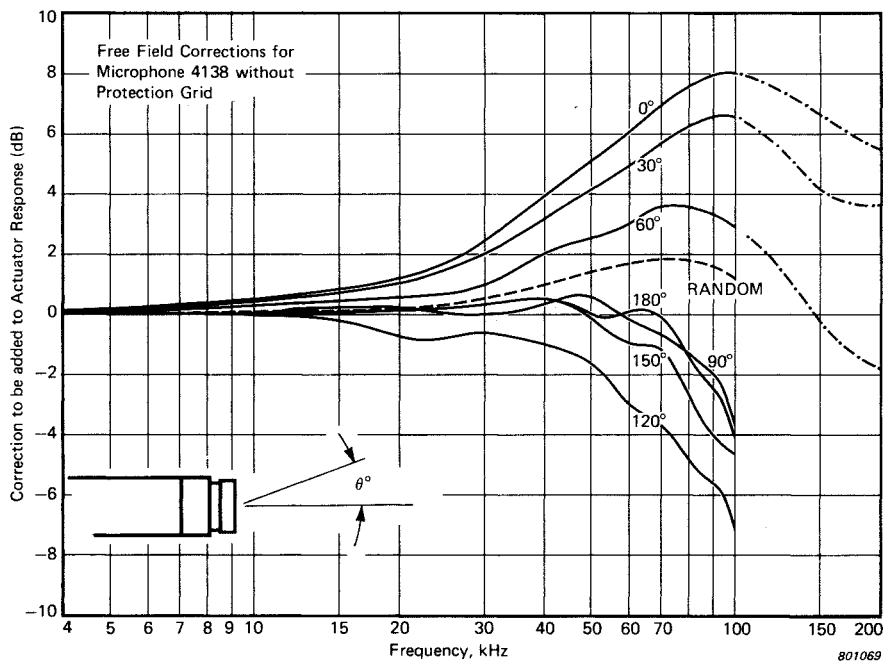

Fig. 6.16. Free-field correction curves for eighth-inch Condenser Microphone Type 4138 without normal protection grid

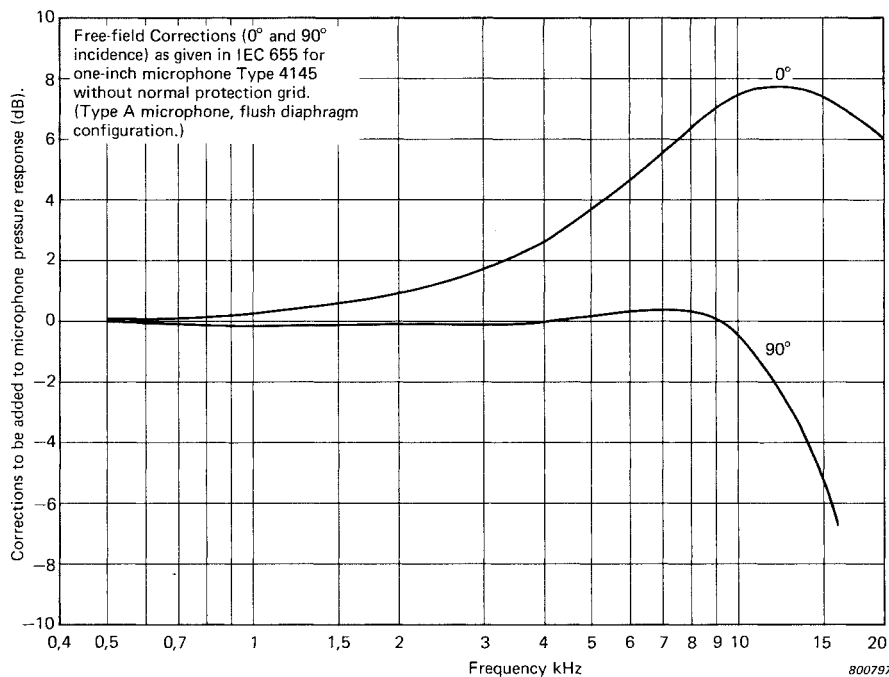

Fig. 6.17. Free-field correction curves for one-inch Condenser Microphone Type 4145 (after IEC 655, Type A microphone) without normal protection grid. Note that corrections apply to microphone pressure response

6.2.4. Pressure Response Microphones

The B & K Pressure Response microphones (Types 4144, 4166, 4134, 4147, 4136, 4138) are designed so that damping of the high frequency response provides a pressure response calibration which is independent of frequency to the highest possible frequency. This means in practice that no correction is required to the nominal pressure response sensitivity of the microphone below 8 kHz for the one-inch microphone 4144, below 9 kHz for the half-inch microphone 4166, below 20 kHz for the half-inch microphone 4134 (below 18 kHz for 4147), below 70 kHz for the quarter-inch microphone 4136, or below 140 kHz for the eighth-inch microphone 4138. These limits are for ± 2 dB on the sensitivity.

The use of pressure response microphones is most advantageous under conditions where the local pressure is of interest, regardless of whether the microphone itself disturbs the sound field. Particular examples are coupler measurements, and measurements at walls or surfaces, where the microphone (possibly without its protection grid) can be mounted with its diaphragm flush with the surrounding surface. Since the one-inch and half-inch pressure response microphones have flatter random incidence responses than the corresponding free-field microphones, these pressure response microphones are best suited for diffuse field measurements. When a one-inch free-field microphone is used for diffuse field measurements, it is recommended that it be used with Random Incidence Corrector UA 0055. With the quarter-inch diameter microphones, however, the situation is reversed and the 4135 is the better random incidence response microphone.

6.2.5. Free-Field Response Microphones

The B & K Free-Field Response microphones (Types 4145, 4165, 4133, 4148, 4149, 4135) are designed so that damping of the high frequency response is such that when the

free-field correction for zero degree incidence (Figs.6.2, 6.4, 6.8, 6.10, 6.12) is added to the electrostatic actuator response characteristic, the resulting free-field response is independent of frequency to the highest possible frequency. This means in practice that sound measurements may be made in a free sound field with the microphone directed at the source with an error of less than ± 2 dB for frequencies below 18,5 kHz for one-inch microphone, below 20 kHz for the half-inch microphone 4165, below 16 kHz for the half-inch microphone 4148, below 40 kHz for 4133 and 4149, below 100 kHz for the quarter-inch microphone 4135. The eighth-inch microphone 4138 has a free-field response which is independent of frequency up to 60 kHz when used at 90° incidence. As a general rule, the error for any incidence is less than 2 dB at the frequency where the diameter of the microphone corresponds to one quarter wavelength. If the incidence of the sound is not well defined, it will always be advantageous to measure with the smallest microphone available.

A fairly flat free-field response is obtained with a pressure response microphone used at 90° incidence, since the free-field correction for this angle is small. It could have advantages when measurements are to be made on sources which move in one plane, since the 90° incidence is independent of source position.

6.2.6. Low Frequency Limit

At frequencies below 20 Hz, the response of the cartridge continues linearly until close to the low frequency limit quoted on the microphone calibration chart. At lower frequencies, the cartridge response is dependent on whether the pressure equalization vent is outside or inside the sound field. The two configurations are shown in Fig.6.18.

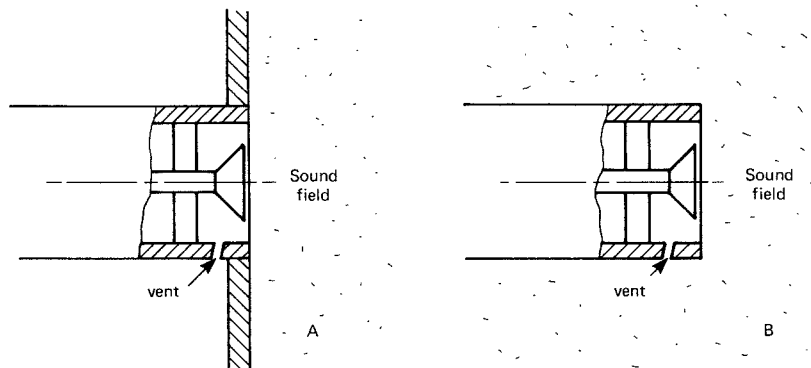

810489

Fig.6.18. Equalization vent outside (A) and inside (B) the sound field

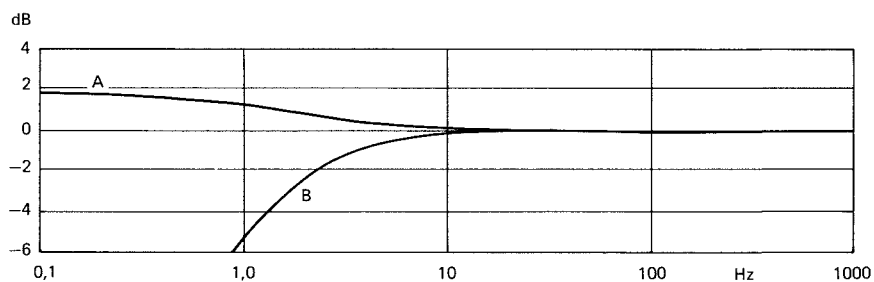

810351

Fig. 6.19. Low frequency response of one-inch microphone Type 4144 (-3 dB point at 1,46 Hz) with static pressure equalization vent outside (curve A) and inside (curve B) the sound field

When the equalization vent is inside the sound field (Fig.6.18.(B)), the cartridge response falls at a rate of approximately 20 dB/decade below the low frequency limit (-3 dB point). An increase in the low frequency response results when the equalization vent is outside the sound field because the exchange of air between the inside and the outside of the cartridge results in a reduction of the total stiffness. In this case the cartridge response theoretically extends to 0 Hz. Fig.6.19 shows the low frequency response for one-inch microphone Type 4144 in both configurations.

6.2.7. Frequency Response in a Helium Atmosphere

When a microphone is placed in a helium atmosphere, a change in the kinetics of the diaphragm motion relative to the normal air atmosphere is inevitable. The resulting changes in the microphone response are shown in Fig.6.20 for one-inch microphones Types 4144 and 4145, and in Fig.6.21 for half-inch microphones Types 4133, 4134, 4147 and 4149.

The parameters which bring about this difference are:

- a) below resonance, the stiffness of the gas in the cavity
- b) at resonance, the viscosity of the gas between diaphragm and backplate
- c) above resonance, the inertia of the gas between diaphragm and backplate.

Figs.6.20 and 6.21 show the changes associated with b) and c), but not the very small change associated with a). The change in stiffness is only of the order 4%.

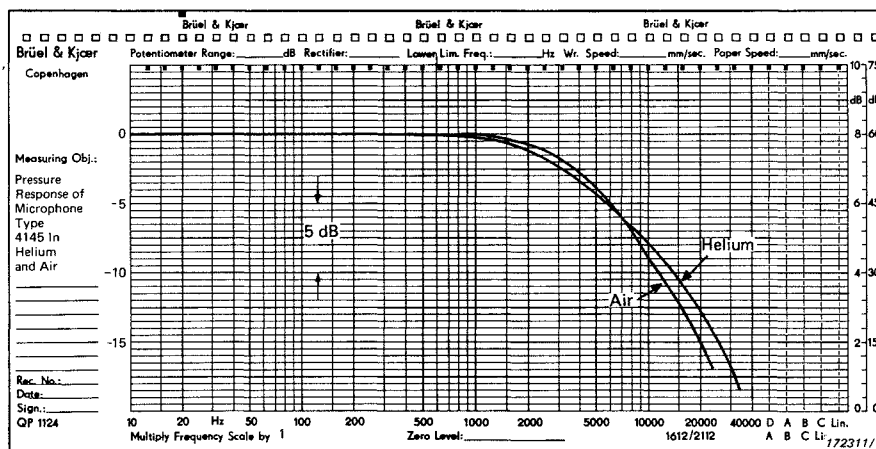
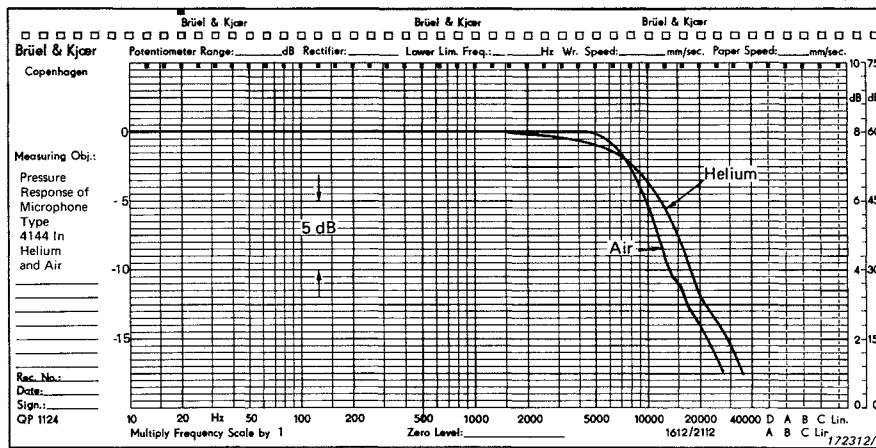

Fig.6.20. Electrostatic actuator frequency response for one-inch microphones in air and helium atmospheres
a) Pressure response microphone Type 4144
b) Free-field response microphone Type 4145

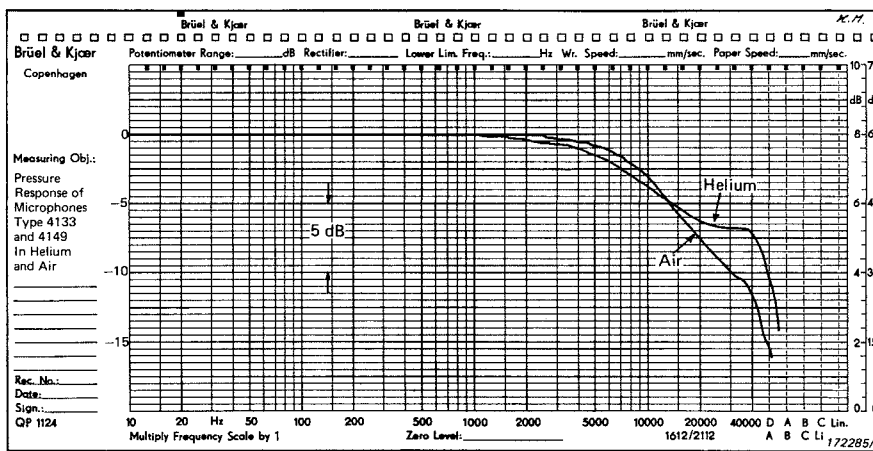
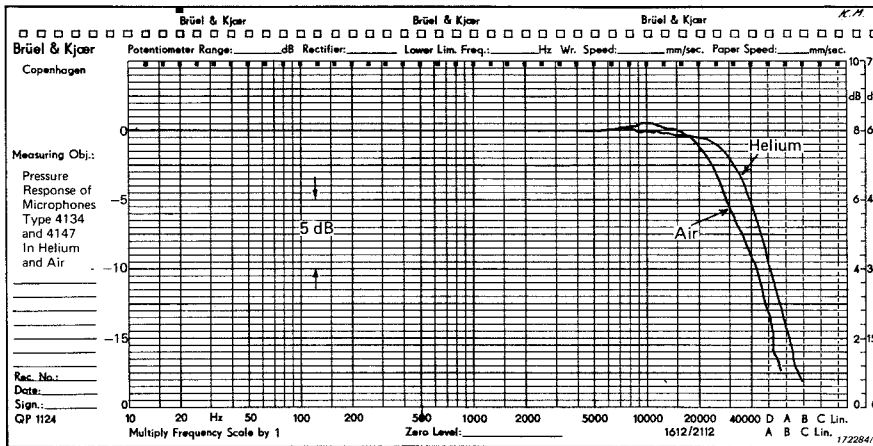

Fig.6.21. Electrostatic actuator frequency response for half-inch microphones Types 4133, 4134, 4147 and 4149 in air and helium atmospheres
a) Pressure response microphones Types 4134 and 4147
b) Free-field response microphones Types 4133 and 4149

6.3. DIRECTIONAL CHARACTERISTICS

Since microphones of similar types have the same mechanical dimensions, the directional characteristics of the microphone and preamplifier combination are similar. The influence of the protecting grid is not well defined at frequencies which are relatively high for the microphone size because of interference of the grid with the sound field at these frequencies.

Typical directional characteristics are given in Figs.6.22 to 6.28. All of these curves are normalised relative to the 0° response and the sensitivity for other angles of incidence can therefore be obtained from these figures together with the individually calibrated frequency response of the microphone.

The omnidirectivity of the one-inch free-field microphone can be improved by fitting the random incidence corrector UA 055 (see section 9.6). More generally, fitting a nose cone to the microphone improves its omnidirectivity; see section 9.4 for details.

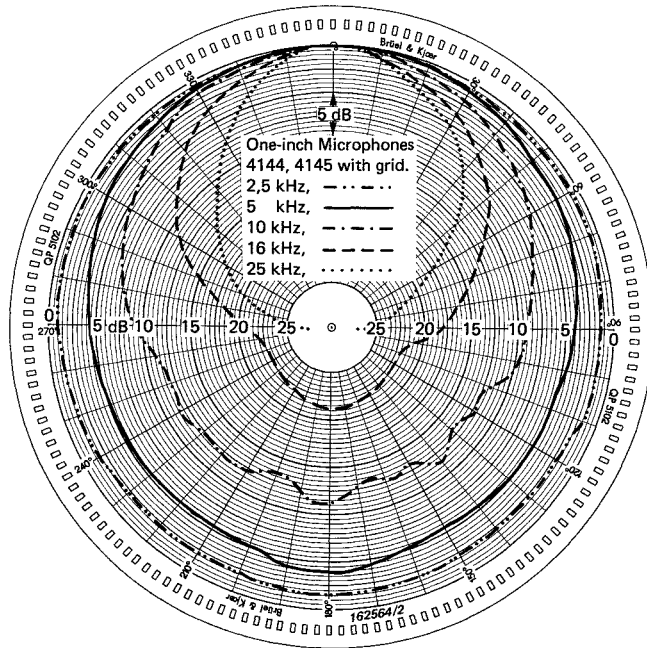

Fig.6.22. Directional characteristics of the one-inch microphones

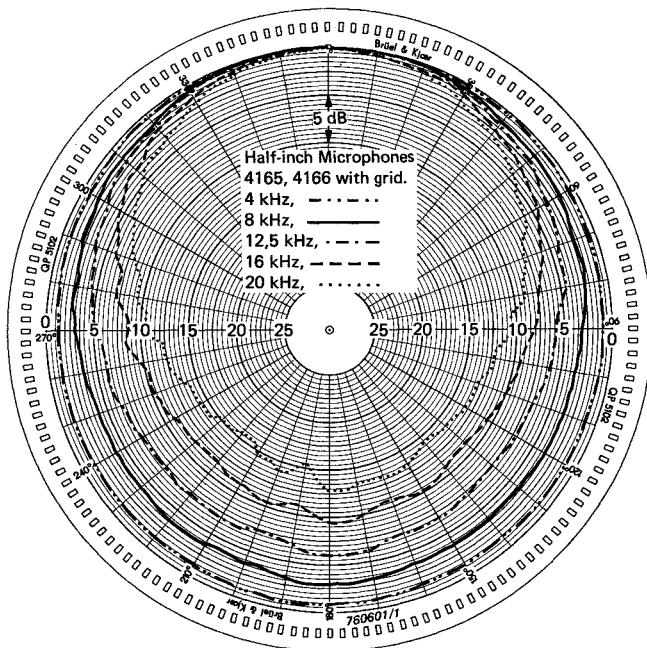

Fig. 6.23. Directional characteristics of half-inch microphones Types 4165 and 4166

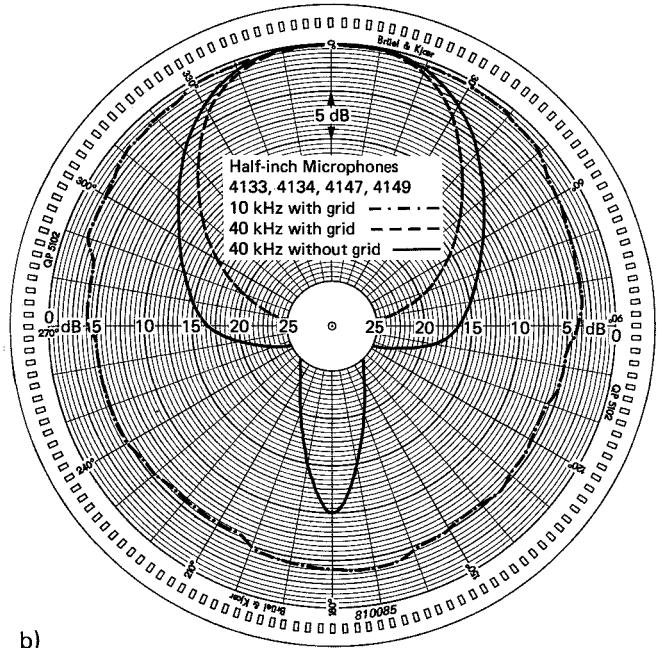
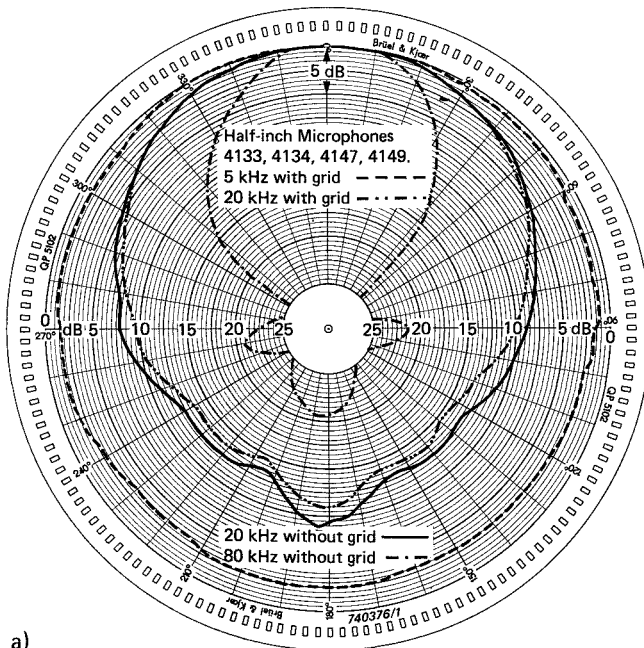

Fig.6.24. Directional characteristics of half-inch microphones Types 4133, 4134, 4147 and 4149
a) 5 kHz, 20 kHz and 80 kHz
b) 10 kHz and 40 kHz

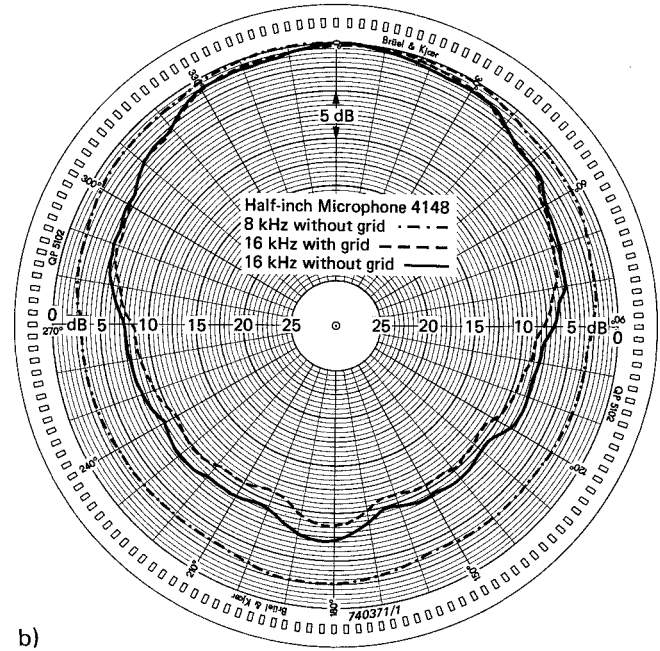
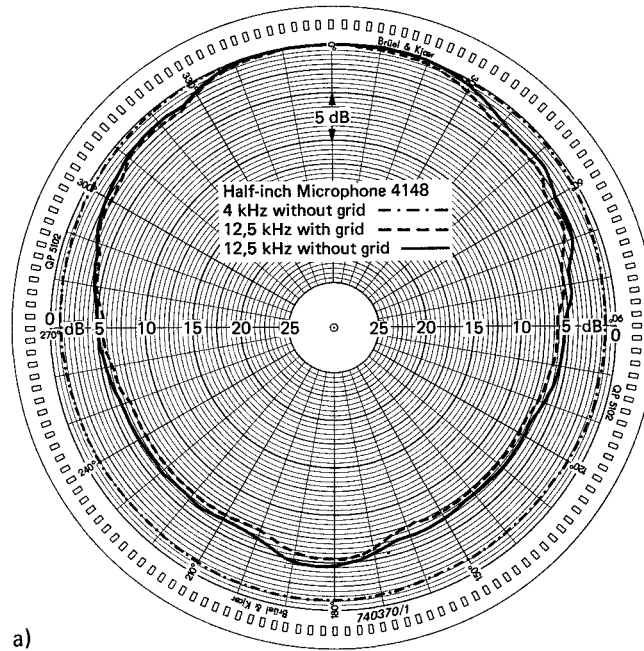
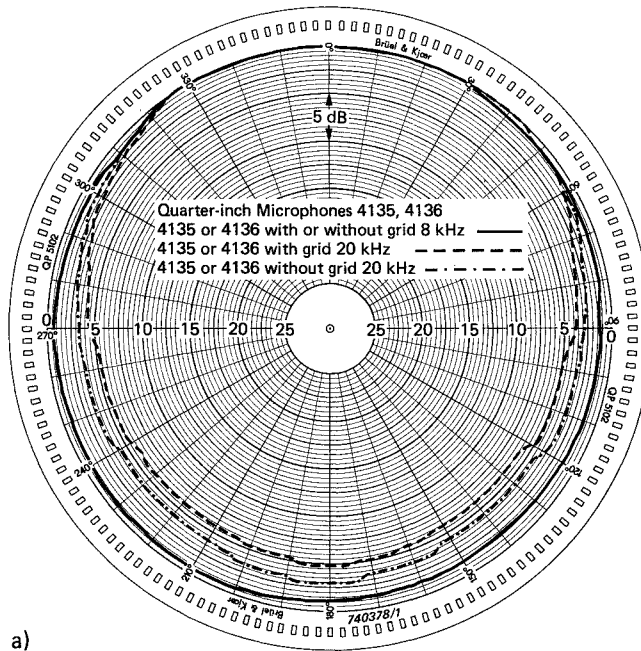
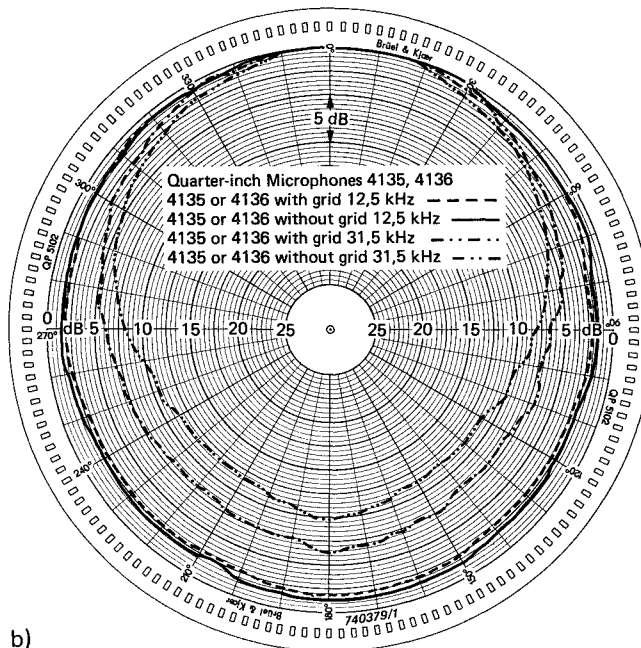

Fig.6.25. Directional characteristics of half-inch microphone Type 4148
a) 4 kHz and 12,5 kHz
b) 8 kHz and 16 kHz



a)



b)

Fig.6.26. Directional characteristics of quarter-inch microphones Types 4135 and 4136 (see also Fig.6.27)

a) 8 kHz and 20 kHz

b) 12,5 kHz and 31,5 kHz

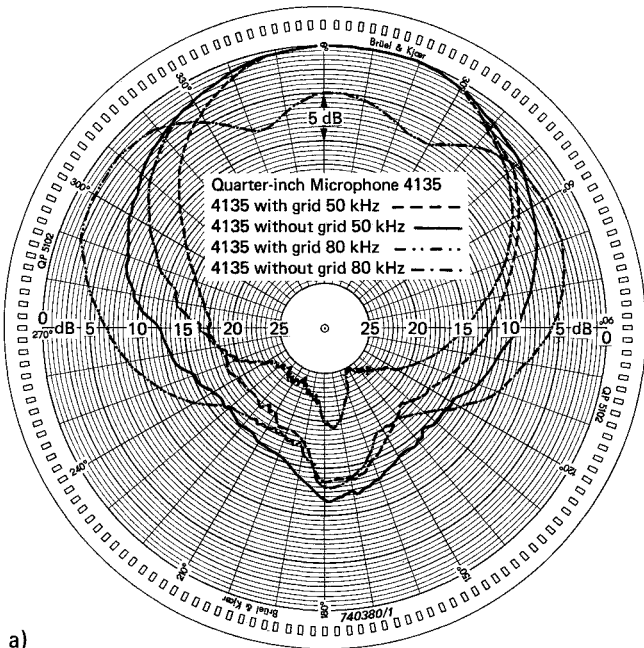

a)

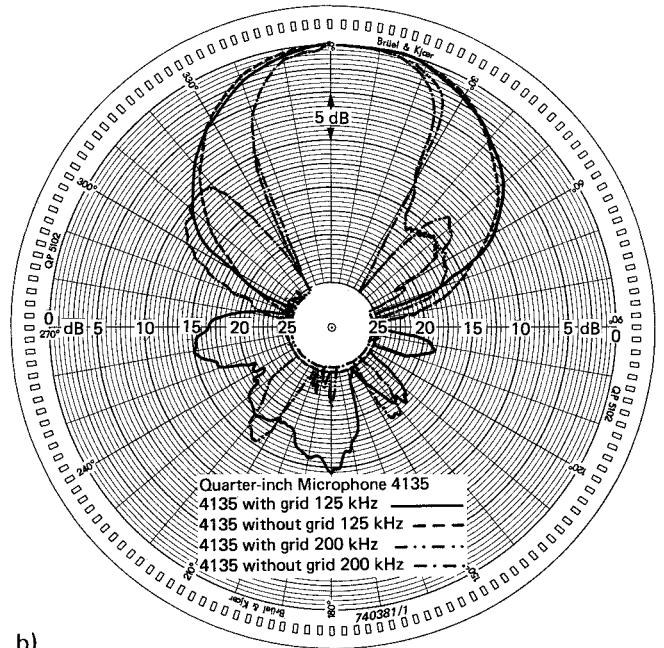

b)

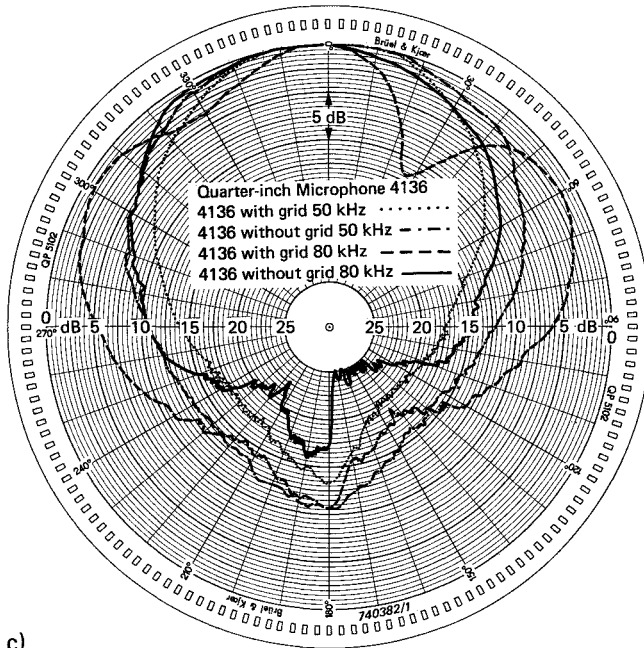

c)

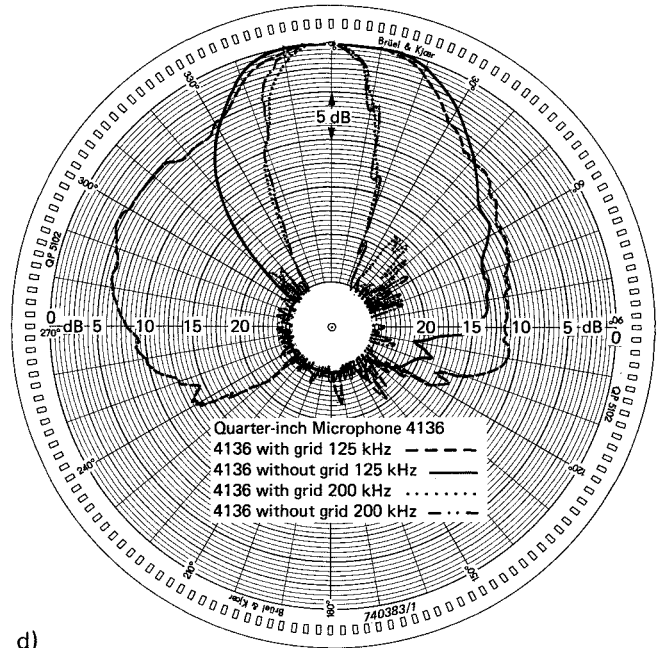

d)

Fig.6.27. Directional characteristics of quarter-inch microphones Types 4135 and 4136 (see also Fig.6.26)

- a) Type 4135 only: 50 kHz and 80 kHz
- b) Type 4135 only: 125 kHz and 200 kHz
- c) Type 4136 only: 50 kHz and 80 kHz
- d) Type 4136 only: 125 kHz and 200 kHz

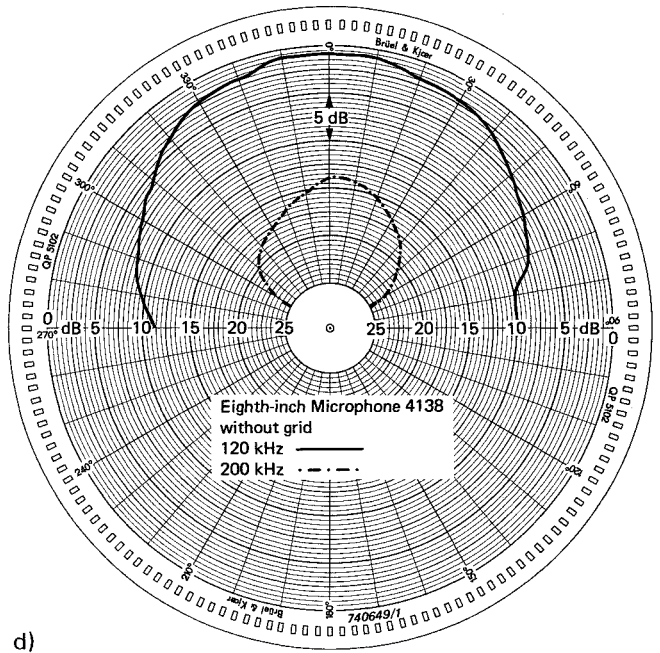
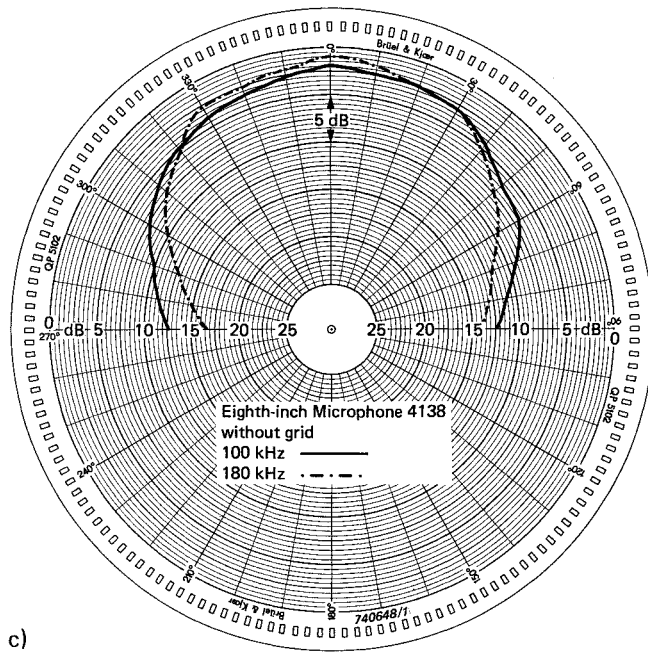
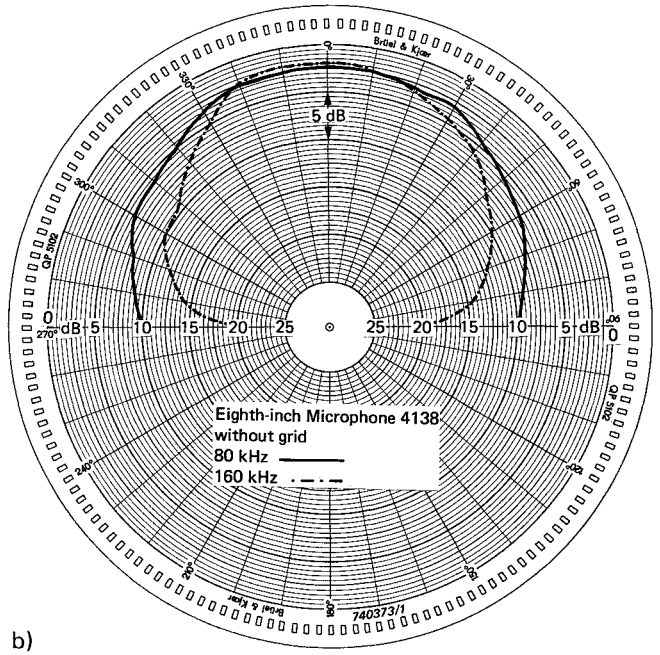
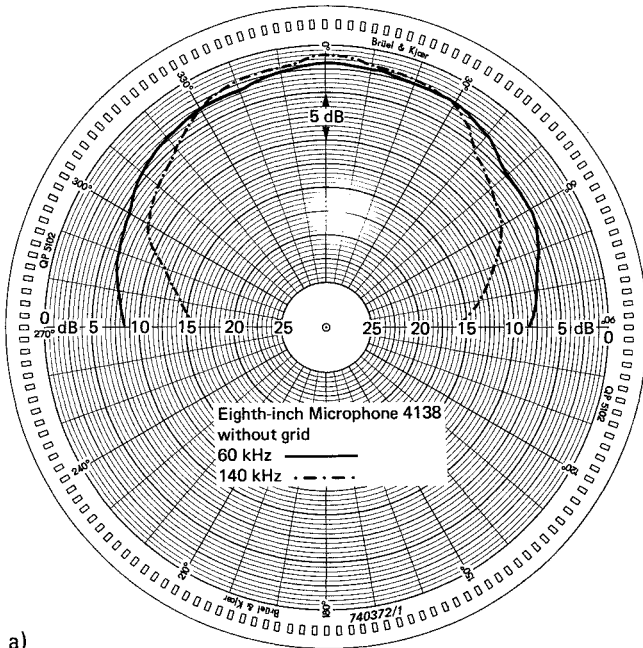

Fig. 6.28. Directional characteristics of eighth-inch microphone Type 4138
 a) 60 kHz and 140 kHz
 b) 80 kHz and 160 kHz
 c) 100 kHz and 180 kHz
 d) 120 kHz and 200 kHz

6.4. DYNAMIC RANGE

The dynamic range of the combined microphone and preamplifier system is characterised by defined upper and lower limits. Upper limits are generally specified for two degrees of distortion (3% and 10%), while the lower limits are given as noise levels for various bandwidths of the associated indicating equipment. The dynamic ranges of the recommended B & K microphone and preamplifier combinations are illustrated in Fig.3.1 and the values given in Table 6.2.

Note the lower limit indicated in Table 6.2 corresponds to the specified maximum noise. Typically, the A-weighted noise limit will be approx. 2 dB below the specified limit. The wide band noise limit will typically be 3 to 4 dB below the specified limit.

Preamplifier Type	Microphone Type		Lower Limit				Upper Limit	
			3,16 Hz at 1 kHz (dB)	1/3 octave at 1 kHz (dB)	A-weighted (dB)	Linear 20 Hz to 20 kHz (dB)	< 3% distortion (dB)	< 10% distortion (dB)
2627	One-Inch	4144	-19	-1	13	22	146	150
		4145		0				
2619	One-Inch	4144	-20	-2	11	18	146	150
		4145	-20	-1				
	Half-Inch	4133	-5	13	26	40*	160	162
		4134				38		
		4148	-6	12	25	38	140	150
		4149	-5	13	26	40	160	162
		4165	-15	4	17	26	146	150
		4166	-16	3				
	Quarter-Inch	4135	12	30	45	56*	164	172
		4136	19	38	53	64*	172	180
	Eighth-Inch	4138	28	47	62	71*	168	178
2633	Quarter-Inch	4135	5	23	39	51*	164	176
		4136	13	32	47	59*	172	180
	Eighth-Inch	4138	23	43	56	68*	168	178
Microphone Carrier System 2631	Half-Inch	4147	30	49	63	73	150	160

* Lin 20 Hz to 200 kHz

810092

Table 6.2. Dynamic ranges of microphone and preamplifier combinations

At normal sound pressure levels the distortion in the microphone is negligible. However, at very high sound pressure levels (> 140 dB for one-inch microphones) appreciable distortion occurs due to the parallel input capacitance of the preamplifier, non-linear motion of the

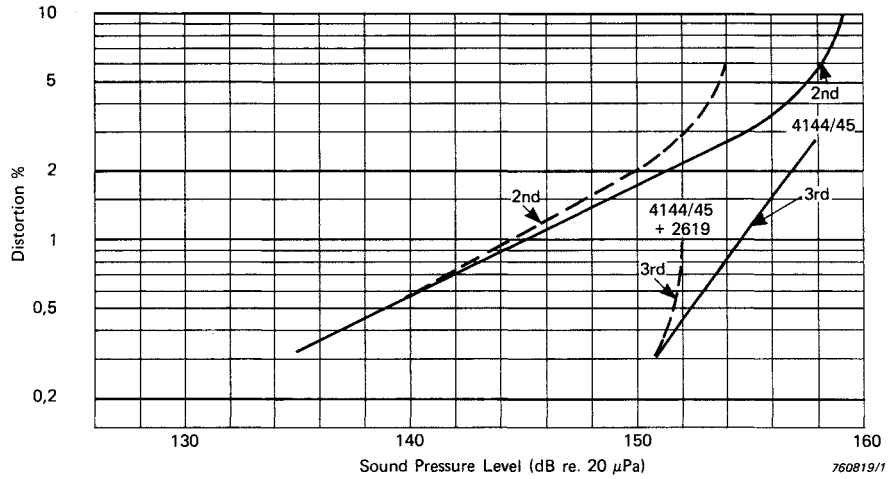

Fig. 6.29. Typical distortion characteristics of the one-inch microphones

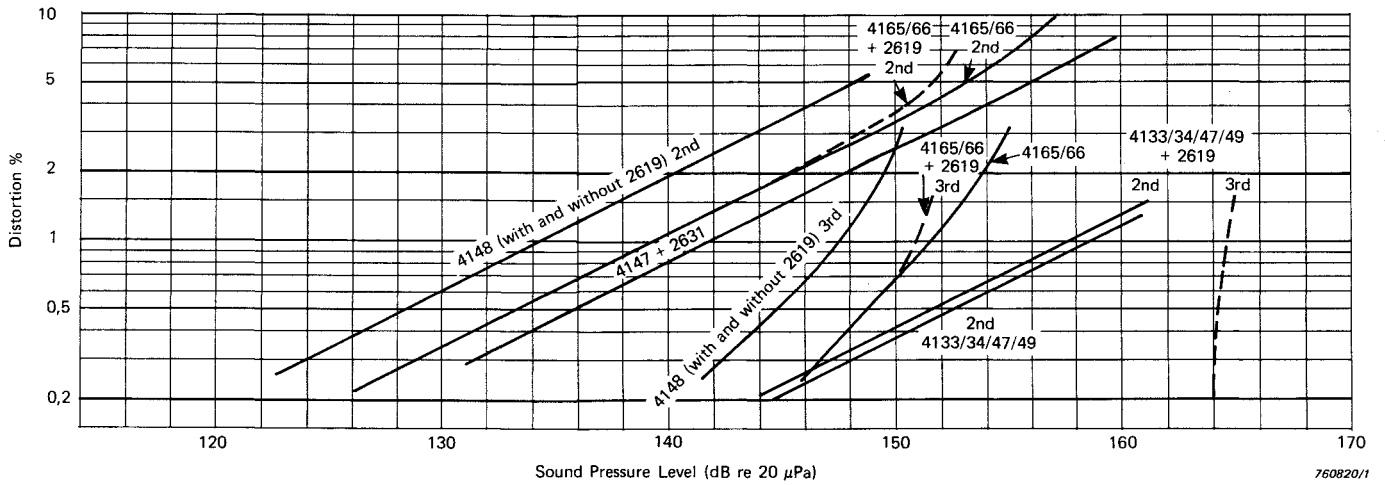

Fig. 6.30. Typical distortion characteristics of the half-inch microphones

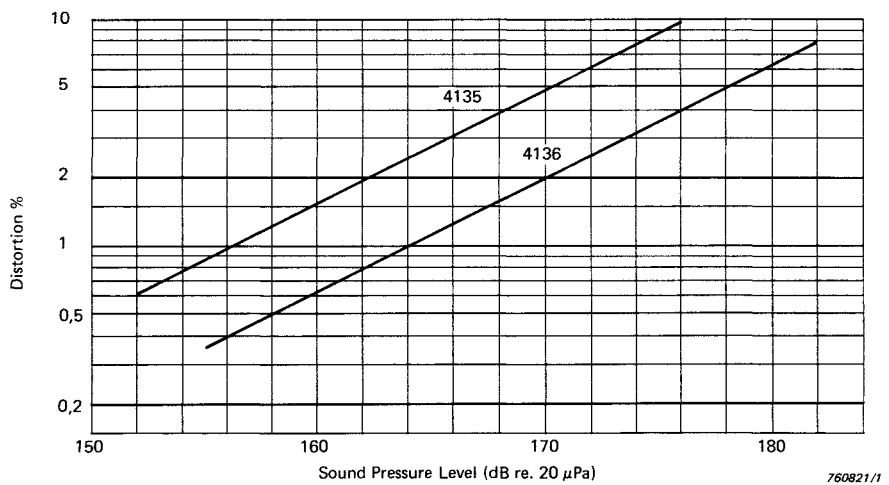

Fig. 6.31. Typical distortion characteristics of the quarter-inch microphones

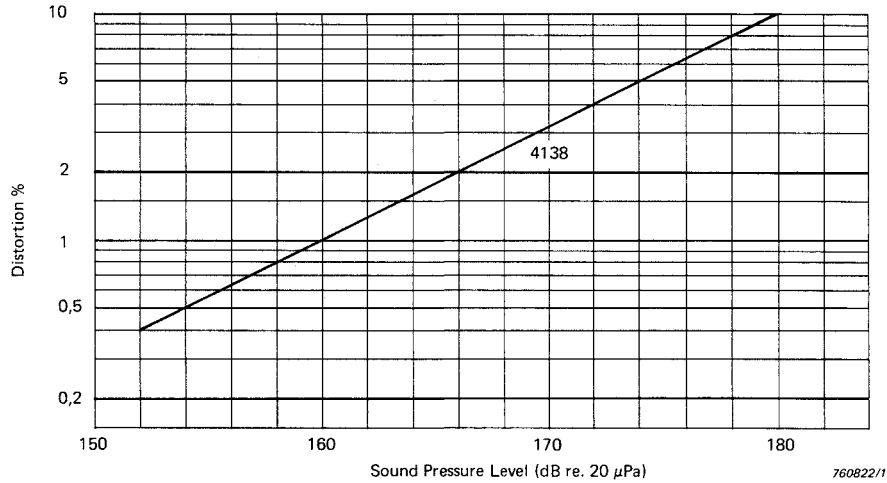

Fig. 6.32. Typical distortion characteristics of the eighth-inch microphone

diaphragm and preamplifier clipping. The upper limit of the useful dynamic range is generally specified as the sound pressure level which produces a 3% harmonic distortion in the combined system output voltage. Distortion levels also depend on the capacitive loading of the preamplifier by extension cables. The distortion characteristics of the microphones are shown in Figs.6.29 to 6.32 for short (2 m) extension cables. The microphones should not be exposed to sound pressure levels greater than the values given in Table 6.3.

In view of the high sensitivity of the microphones and the low inherent noise levels of microphone preamplifiers, the inherent thermal noise of the microphone cartridge itself must be taken into account in determining the lowest level to which the combined system can measure. The lower limit of the dynamic range, therefore, is determined by either the electrical noise of the preamplifier, or the inherent thermal noise of the cartridge. With the most sensitive cartridges, the preamplifier noise component will generally be dominant at low frequencies and the cartridge noise component dominant at high frequencies.

The cartridge thermal noise, which is due to thermal agitation of the diaphragm, may be represented by an effective noise pressure \bar{p} which is a function of the ambient temperature and the measurement bandwidth:

Microphone Type		Maximum Sound Pressure Level dB re 20 μPa
One-Inch	4144, 4145	160
Half-Inch	4133, 4134 4147, 4149	174
	4165, 4166	160
	4148	154
Quarter-Inch	4135	178
	4136	186
Eighth-Inch	4138	178

810074

Table 6.3. Maximum sound pressure level to which the microphones may be exposed

$$\bar{p} = \sqrt{4kTR\Delta f} \quad (6.4)$$

where: k = Boltzmann's constant = $1,38 \times 10^{-23}$ J/K
 T = absolute ambient temperature (Kelvin)
 R = acoustical damping resistance of diaphragm system (Nsm^{-5})
 Δf = measurement bandwidth (Hz).

The noise pressure \bar{p} , which is acting on the diaphragm, results in a noise spectrum corresponding to the cartridge frequency response when measured with a constant bandwidth. An overall measure of the thermal noise of the microphones is given by the Inherent Noise Levels in Table 6.4. This level is the A-weighted effective sound pressure level due to the cartridge noise. The noise voltage present at the microphone output terminals may be found by multiplying the Normalised Noise Pressure value, also given in Table 6.4, by the cartridge sensitivity at the corresponding frequency and the square root of the measurement bandwidth. Figs.6.33 to 6.38 show estimated third-octave analysis inherent noise spectra for one-inch cartridges Types 4144 and 4145, and half-inch cartridges Types 4165, 4166, 4133 and 4134 respectively. Third-octave analysis noise spectra are also shown for the combined microphone and preamplifier (Type 2619) system. The inherent noise levels of the one-inch microphones are very low, permitting signals to be detected down to levels of approximately -19 dB using a 3,16 Hz narrow band filtering. For the cartridge Types shown, the overall system noise is dominated by the preamplifier noise component at low frequency. The cartridge noise component increases at approximately 3 dB per octave and becomes dominant at higher frequencies up to the limit of the cartridge frequency response. For the quarter-inch and eighth-inch microphones the preamplifier noise component is dominant over the entire frequency range. The lower limit of the dynamic range is considerably higher for these microphones due to the smaller cartridge capacitance which increases the preamplifier noise level and the lower sensitivity of the cartridges.

For further details, see B & K Technical Review No.3 1972 "Thermal Noise in Microphones and Preamplifiers".

Microphone Type		Normalised Noise Pressure ($\mu\text{Pa}/\sqrt{\text{Hz}}$)	Inherent Noise Level (dB(A) re 20 μPa)	Broad-Band Noise Level dB re 20 μPa
One-Inch	4144	0,6	9,5	10
	4145	0,9	10	10,5
Half-Inch	4133	2,2	20	21,5
	4134	1,3	18	21,5
	4147			
	4148	1,0	12,5	12,5
	4149	2,2	20	21,5
	4165	1,2	14,5	15,5
	4166	1,1	15	15,5
Quarter-Inch	4135	5,7	29,5	34
	4136		30,5	37,5

810075

Table 6.4. Cartridge inherent noise specifications

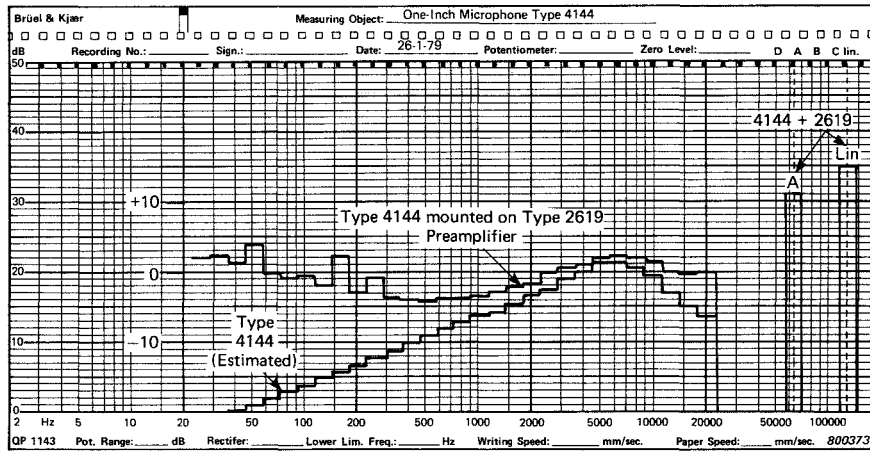

Fig.6.33. Third-octave inherent noise spectrum of one-inch microphone Type 4144

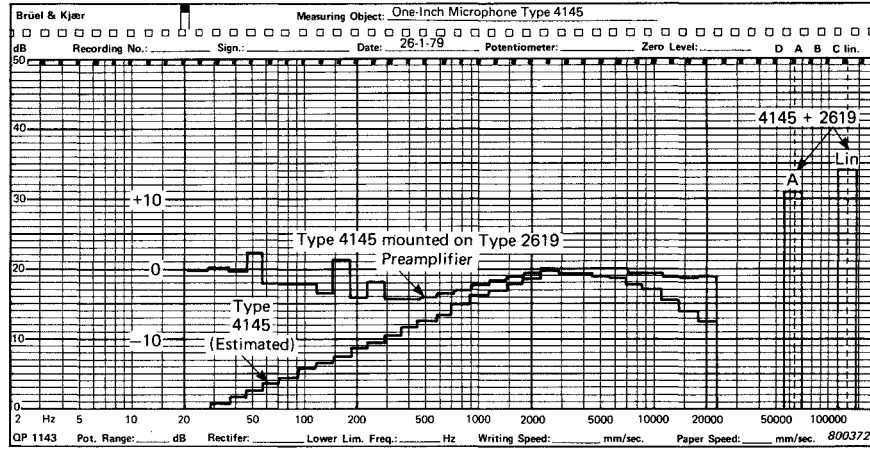

Fig.6.34. Third-octave inherent noise spectrum of one-inch microphone Type 4145

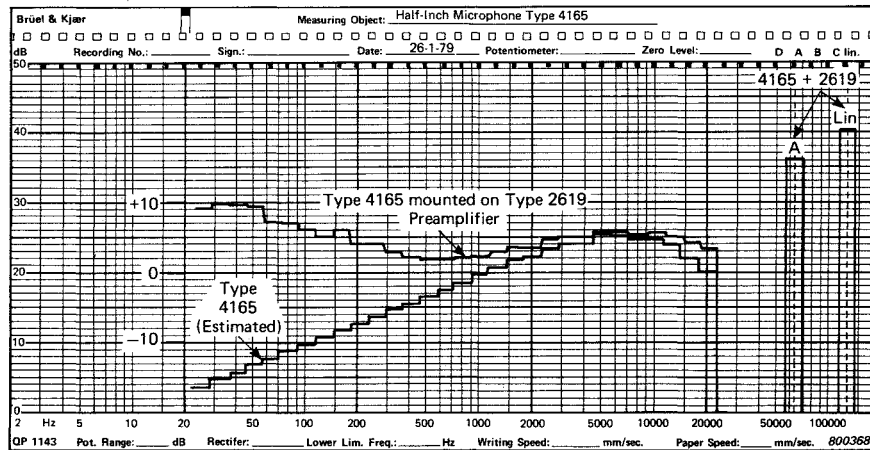

Fig.6.35. Third-octave inherent noise spectrum of half-inch microphone Type 4165

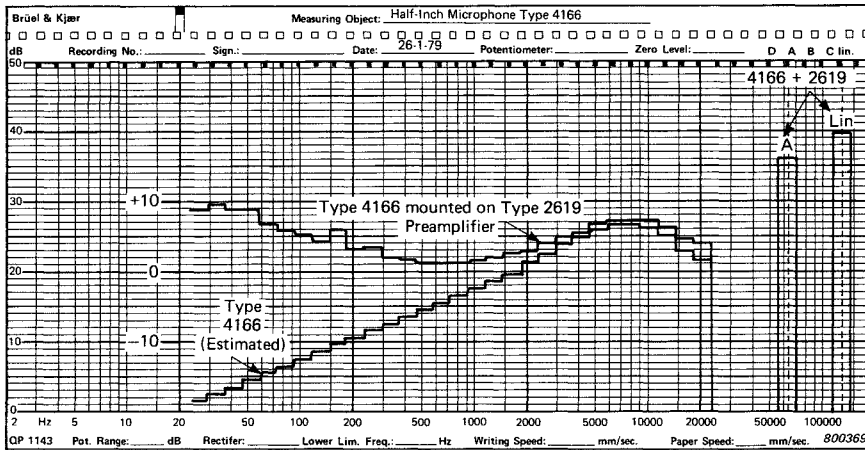

Fig.6.36. Third-octave inherent noise spectrum of half-inch microphone Type 4166

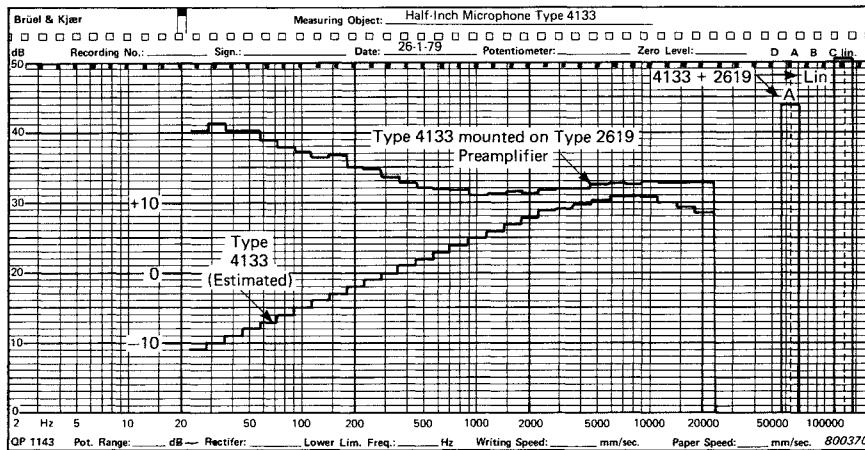

Fig.6.37. Third-octave inherent noise spectrum of half-inch microphone Type 4133

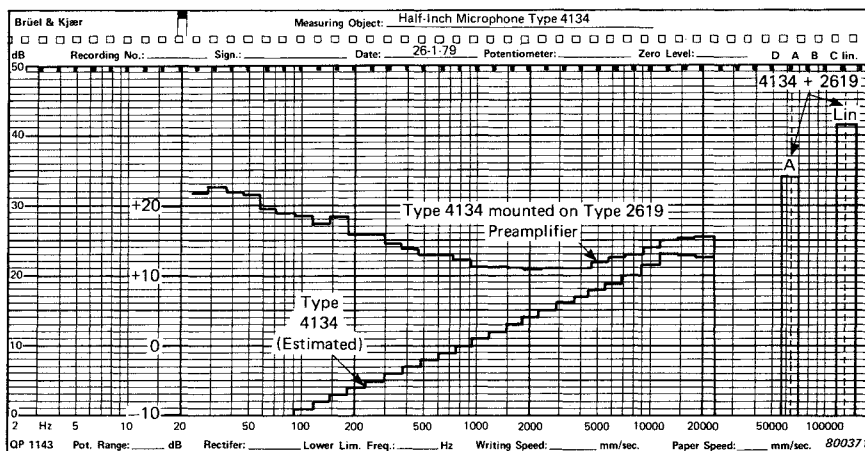
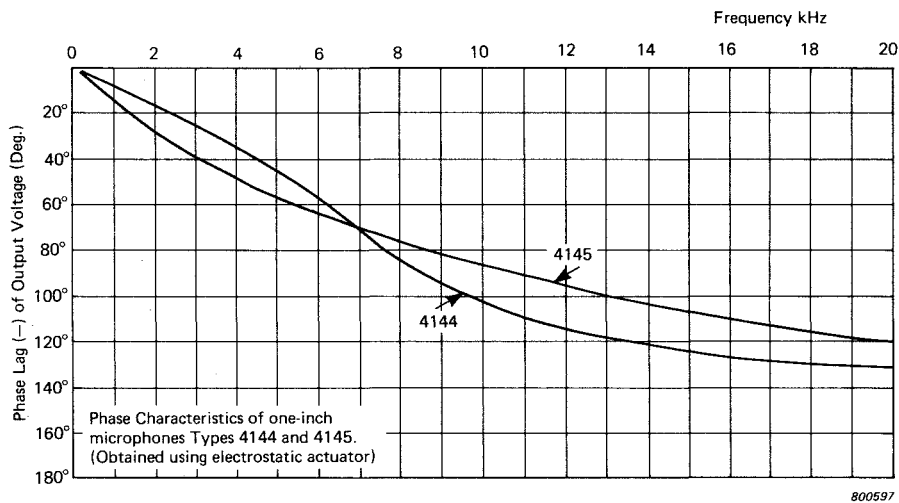

Fig.6.38. Third-octave inherent noise spectrum of half-inch microphone Type 4134

6.5. PHASE CHARACTERISTICS AND PULSE RESPONSE

In operation the microphones use a system of positive polarization on the backplate, and therefore at low frequencies a phase inversion occurs, the preamplifier output voltage being negative going for a positive going incident sound pressure. The phase response characteristics of the microphones, obtained using an electrostatic actuator, are shown in Figs.6.39 to 6.43. For practical purposes the actuator response curve corresponds to the pressure phase response of the microphone. The resonance frequency of the microphone is defined by a phase lag of 90° .

The free-field phase response of the microphones may be obtained for 0° incidence using the actuator phase response curve and the estimated free-field phase correction curve shown in Fig.6.44. An example of this is shown in Fig.6.45 for half-inch microphone Type 4133. At 20 kHz the actuator response curve shows a phase lag of 80° . The corresponding free-field phase correction at this frequency is a phase lead of $16,5^\circ$. The resulting free-field phase response at 20 kHz is therefore an overall phase of $-80^\circ + 16,5^\circ$, i.e. a phase lag of $63,5^\circ$.



800597

Fig.6.39. Pressure phase response of one-inch microphones Types 4144 and 4145

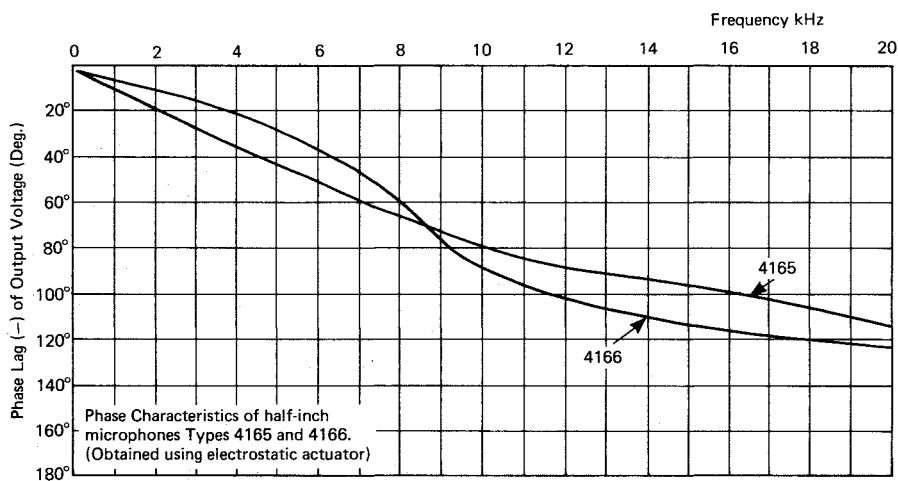

800599

Fig.6.40. Pressure phase response of half-inch microphones Types 4165 and 4166

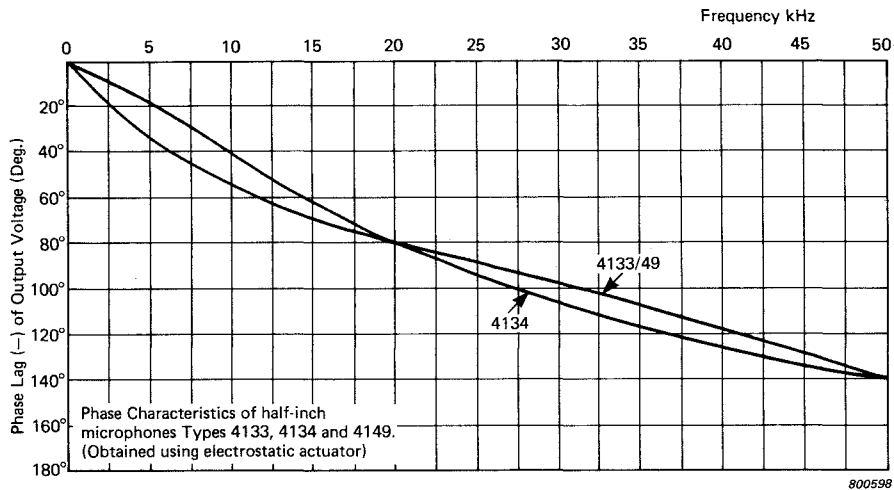

Fig.6.41. Pressure phase response of half-inch microphones Types 4133, 4134 and 4149

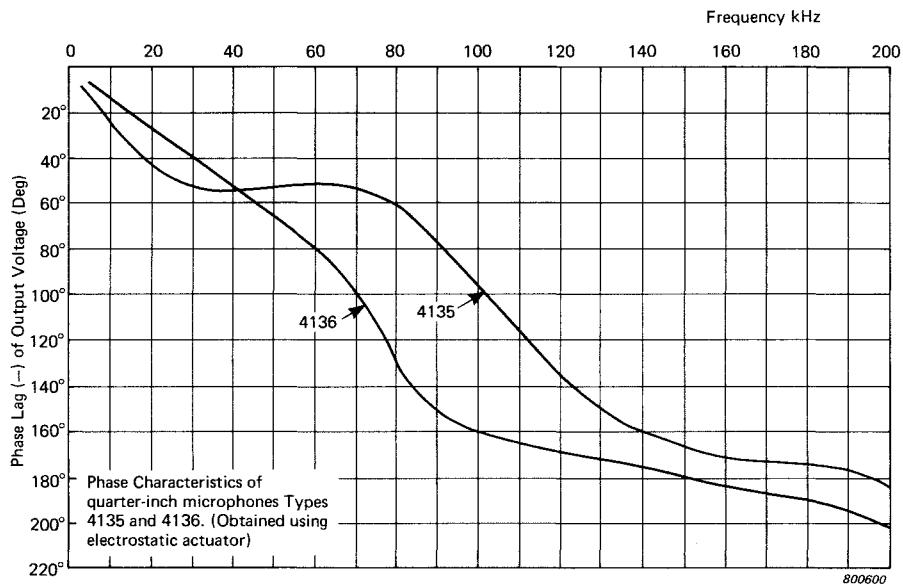

Fig.6.42. Pressure phase response of quarter-inch microphones Types 4135 and 4136

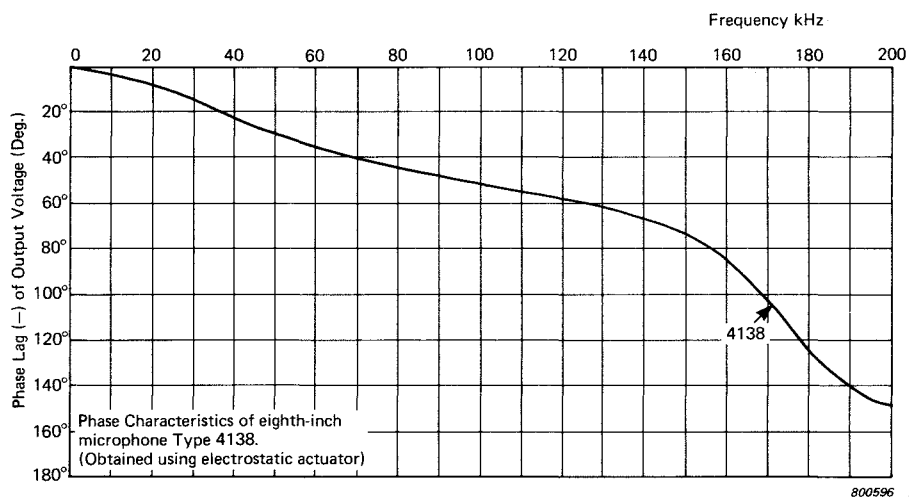

Fig.6.43. Pressure phase response of eighth-inch microphone Type 4138

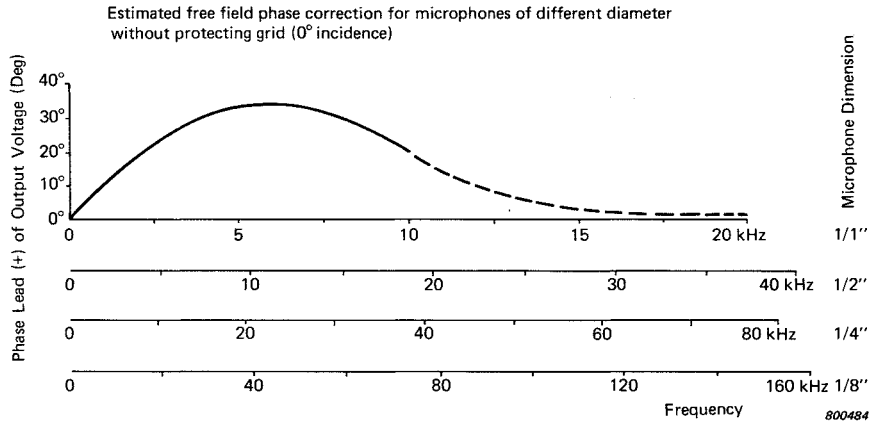

Fig.6.44. Estimated free-field phase correction for all microphone types without normal protection grid

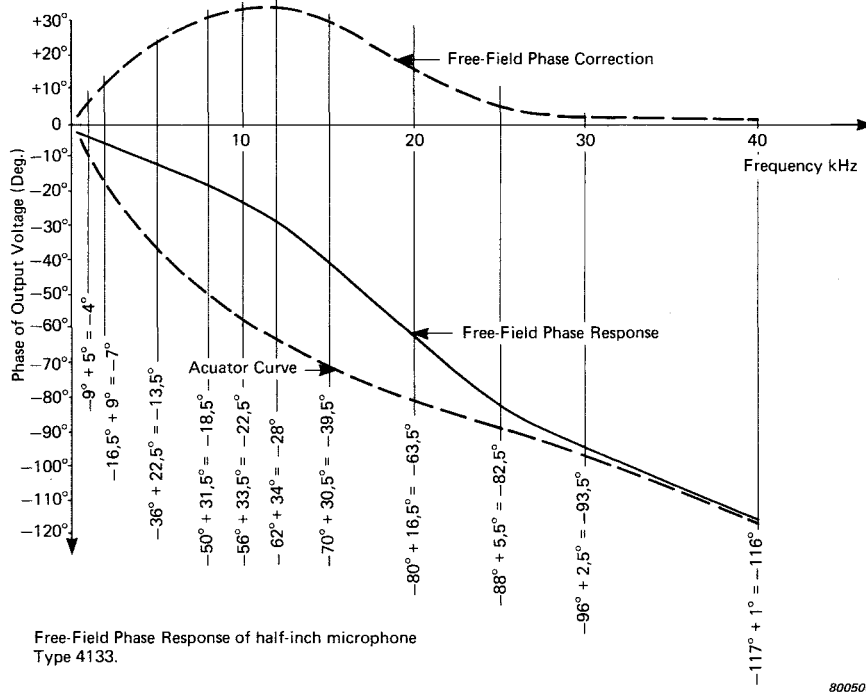

Fig.6.45. Free-field phase response of half-inch microphone Type 4133 obtained using the pressure phase response curve (Fig.6.41) and the estimated free-field phase correction

Microphone pulse responses are compared in Fig.6.46. In Fig.6.46(a) one-inch, half-inch and quarter-inch microphones are excited by a rectangular pulse at a frequency of 2 kHz. The crest factor of the pulse was varied by altering the pulse duration, crest factors of 10, 5, 2, and $\sqrt{2}$ being produced by pulse durations of 5, 19, 100, 250 μ s respectively. The 19 μ s pulse is repeated with an expanded time base, which is also the time base corresponding to the 5 μ s pulse. Fig.6.45(b) compares the response of the two quarter-inch microphones Types 4135 and 4136 and the eighth-inch microphone Type 4138 to a 20 μ s pulse. The marked difference between the responses of Types 4135 and 4136 is due to the difference in diaphragm thickness of the two microphones and the interaction of the two major resonance modes of the diaphragm.

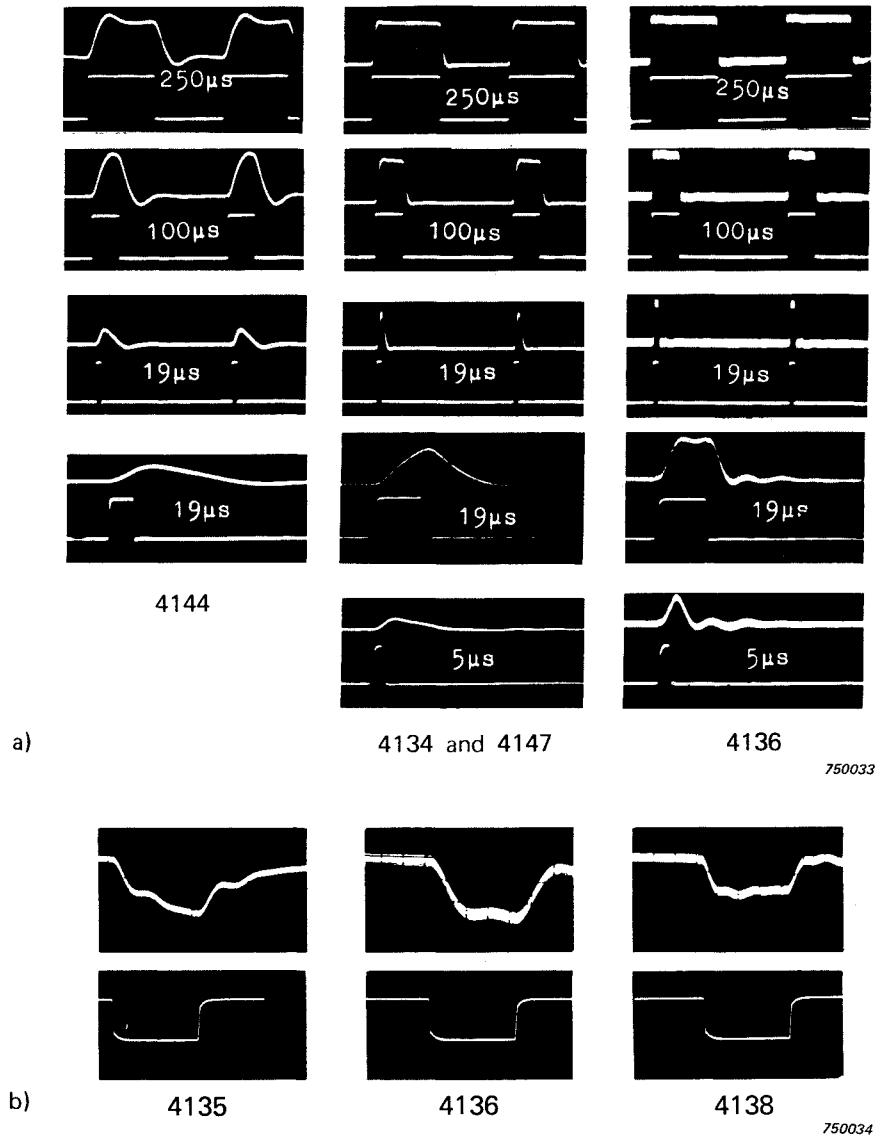

Fig. 6.46. Comparative pulse responses of the microphones
 a) Response of one-inch, half-inch and quarter-inch microphones to pulses of varying duration
 b) Response of quarter-inch and eighth-inch microphones to a 20 μs pulse

6.6. EQUIVALENT VOLUME

When accurate measurements have to be made inside small cavities, the equivalent volume of the microphone must be considered. When the microphone diaphragm forms part of the boundary of a cavity, the diaphragm will not act as a rigid wall, but will move due to the sound pressure. This movement will make the coupler volume appear larger than it really is up to the resonance frequency of the microphone (above which the incremental volume becomes negative). Due to the damping of the diaphragm, the equivalent volume also has an imaginary component, which has its maximum on the frequency range just below the resonance frequency. This increment in cavity volume due to the microphone is known as the equivalent volume of the microphone.

The driving point impedance of the microphone (the ratio of the uniform sound pressure over the diaphragm to the volume velocity of the diaphragm) can be expressed in terms of the equivalent volume, V_e :

$$V_e = \frac{\gamma P}{j\omega Z_a} \quad (6.5)$$

where γ = the ratio of the specific heats of the gas in the coupler
 P = ambient pressure
 Z_a = the acoustic driving point impedance
 ω = the angular frequency (= $2\pi f$)

Note that V_e is a function of ambient pressure.

The method of measuring equivalent volume is given in section 7.5.5. Since it is of importance only for closed cavity measurements, the figures given here are for the one-inch microphones (Figs.6.47 and 6.48) and for the half-inch pressure response microphone 4134 (Fig.6.49). The equivalent volumes of the various microphone types at 250 Hz are of the order shown in Table 6.5.

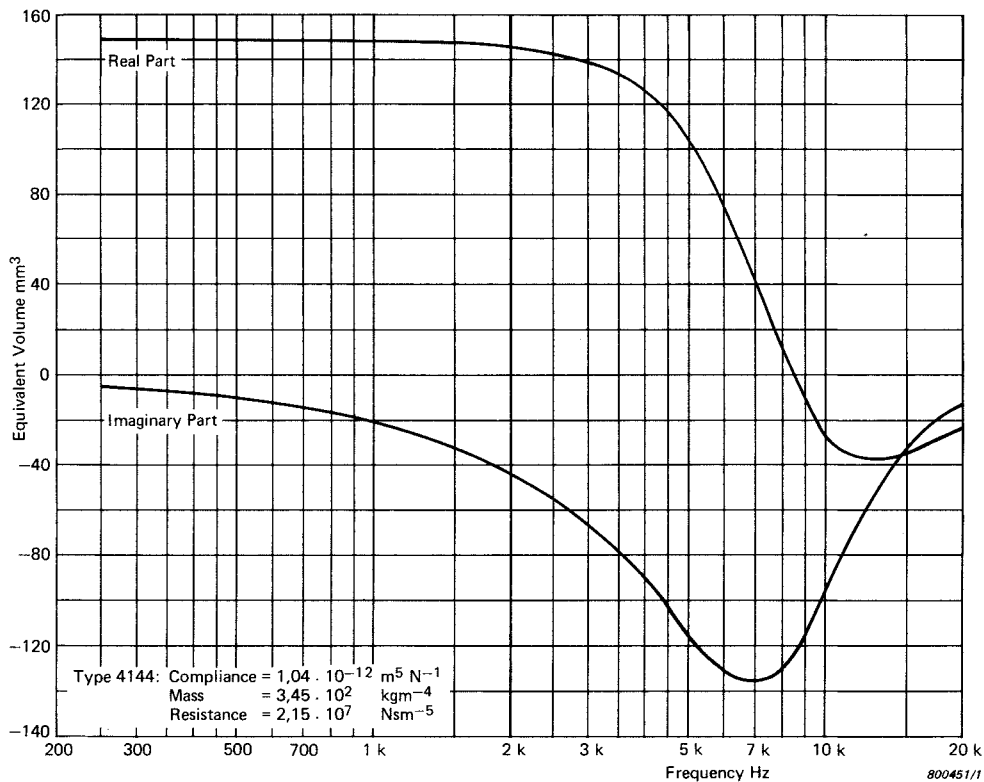

Fig.6.47. Typical equivalent volume of one-inch pressure response microphone Type 4144

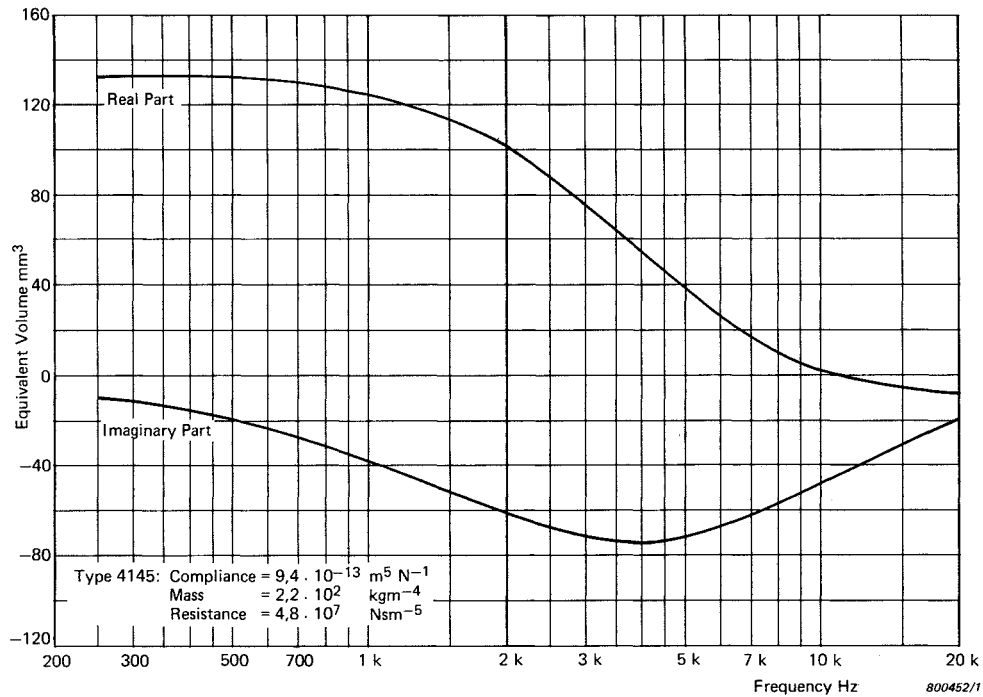

Fig.6.48. Typical equivalent volume of one-inch free-field response microphone Type 4145

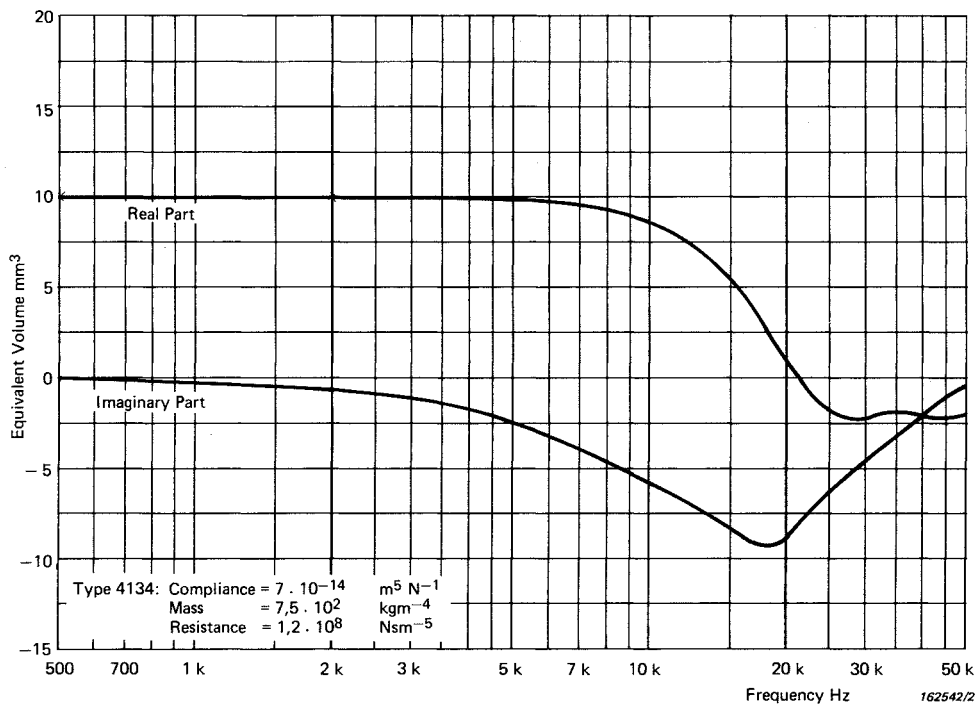

Fig.6.49. Typical equivalent volume of half-inch pressure response microphone Type 4134

Microphone Type		Typical Equivalent Volume at 250 Hz (mm ³)
One-Inch	4144	148
	4145	130
Half-Inch	4148	80
	4165, 4166	40
	4133, 4134 4147, 4149	10
Quarter-Inch	4135	0,6
	4136	0,25
Eighth-Inch	4138	0,1

810076

Table 6.5. Equivalent volumes at 250 Hz

6.7. CAPACITANCE

The microphone cartridge capacitance with 200 V polarization is measured for each individual cartridge at 250 Hz and is quoted on its calibration chart. Nominal values are given in Table 3.1. Owing to the effects of diaphragm movement, however, capacitance of the polarized cartridge is slightly variable with frequency. For the one-inch microphone Types 4144 and 4145 and the half-inch microphones Types 4165 and 4166, the variation is shown for various polarization voltages in Figs.6.50 to 6.53 respectively. For the other half-inch types, variation of capacitance at 200 V polarization is shown in Fig.6.54.

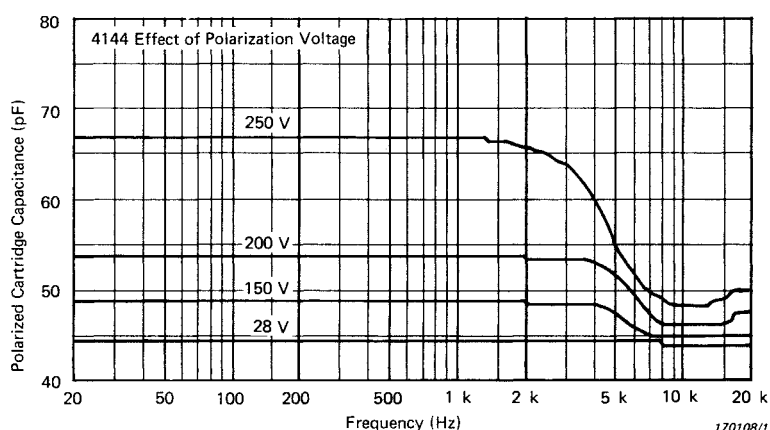

170108/1

Fig.6.50. Variation of cartridge capacitance with polarization voltage and frequency for one-inch pressure response microphone Type 4144

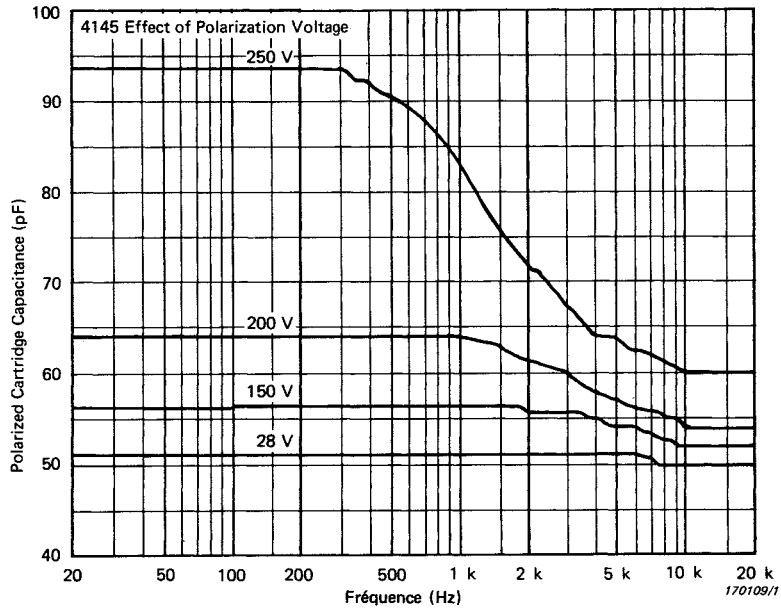

Fig.6.51. Variation of cartridge capacitance with polarization voltage and frequency for one-inch free-field response microphone Type 4145

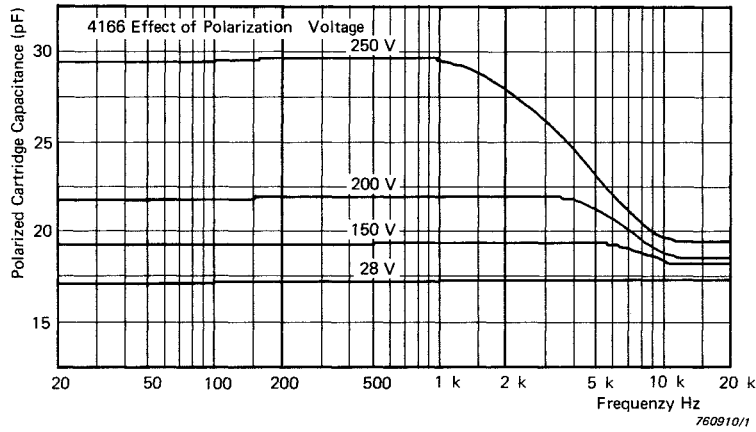

Fig.6.52. Variation of cartridge capacitance with polarization voltage and frequency for half-inch pressure response microphone Type 4166

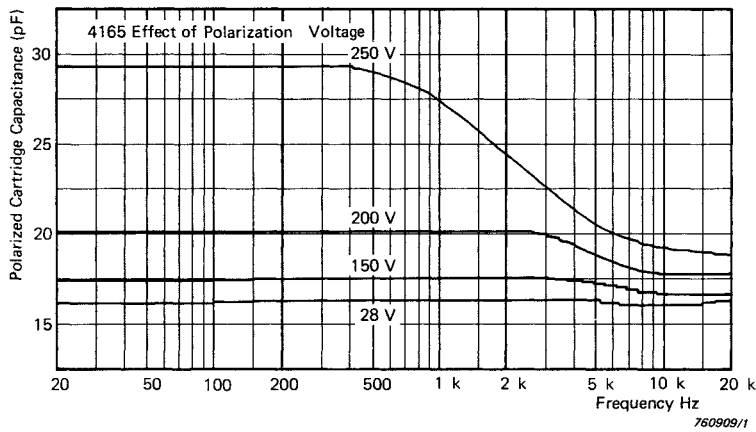

Fig.6.53. Variation of cartridge capacitance with polarization voltage and frequency for half-inch free-field response microphone Type 4165

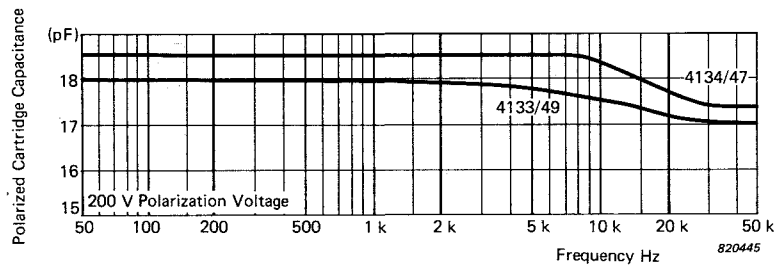

Fig.6.54. Variation of cartridge capacitance of half-inch microphones Types 4133, 4134, 4147 and 4149 at 200 V polarization

If polarization voltage is reduced, so is the degree of electromechanical coupling. This results in the capacitance of the cartridge becoming independent of frequency, as shown in Figs.6.50 to 6.53. For the 4147, cartridge capacitance in pF is given by:

$$C = \frac{18}{1 - 7 \cdot 10^{-5} P} + 1,4 \quad (6.6)$$

where P = pressure difference across the diaphragm (Pa).

6.8. POLARIZATION VOLTAGE

With the exception of the half-inch microphones Types 4147 and 4148, the microphones are designed to operate with a DC polarization voltage of 200 V. The 4147 may be used (with some modification of its frequency response) at 200 V polarization (see Fig.6.65) but it is principally designed for use with the Microphone Carrier System 2631 with which its frequency response is identical to that at 28 V DC polarization. Nominal polarization voltage of the 4148 is 28 V. All the data supplied with the microphone cartridges are for a polarization voltage of 200 V (28 V for 4147 and 4148). The maximum polarization which may be applied is 250 V (120 V for 4148). Any voltage greater than this may damage the microphone.

Sensitivity variation at 250 Hz as a function of polarization voltage is given in Figs.6.55 to 6.58 for the one-inch and half-inch microphones. The quarter-inch microphone sensitivities are directly proportional to polarization voltage (to $\pm 0,20$ dB) over the range of polarization voltages from 150 V to 250 V. Variation in frequency response with polarization voltage is given for the one-inch and half-inch microphone types in Figs.6.59 to 6.66. The variation is due mainly to the change in distance between the diaphragm and backplate of the microphone which affects the damping of the diaphragm motion around resonance.

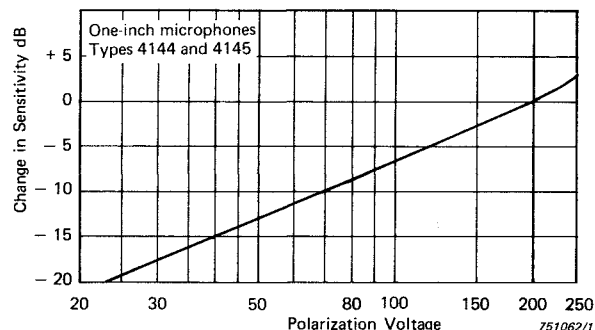

Fig.6.55. Sensitivity variation of one-inch microphones Types 4144 and 4145 at 250 Hz as a function of polarization voltage

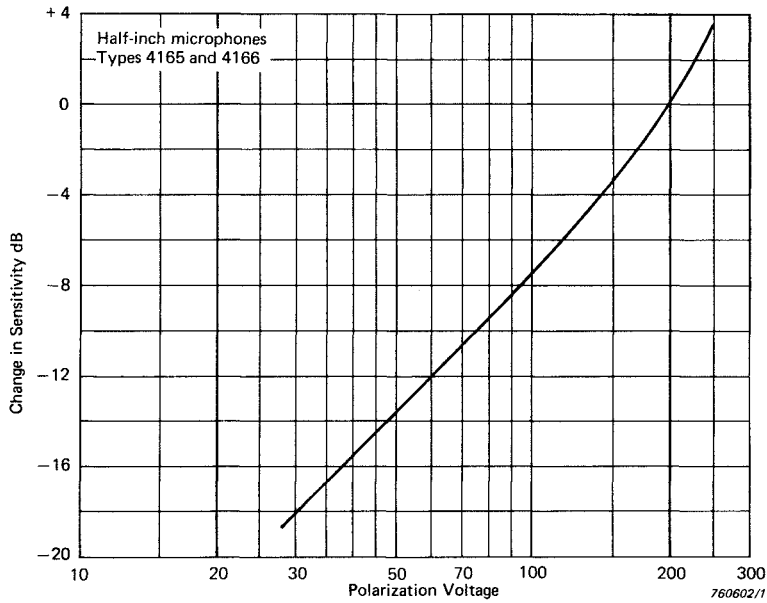

Fig. 6.56. Sensitivity variation of half-inch microphones Types 4165 and 4166 at 250 Hz as a function of polarization voltage

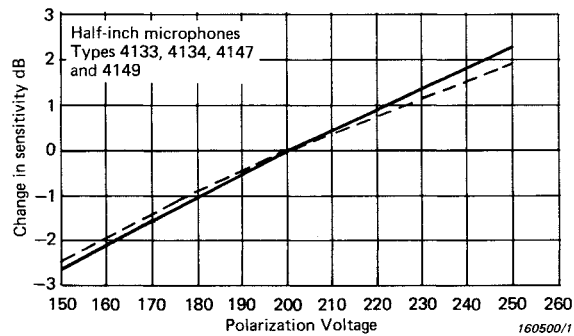

Fig. 6.57. Sensitivity variation of half-inch microphones Types 4133, 4134, 4147 and 4149 at 250 Hz as a function of polarization voltage. The dashed line indicates the theoretical relationship, not allowing for electrostatic attraction

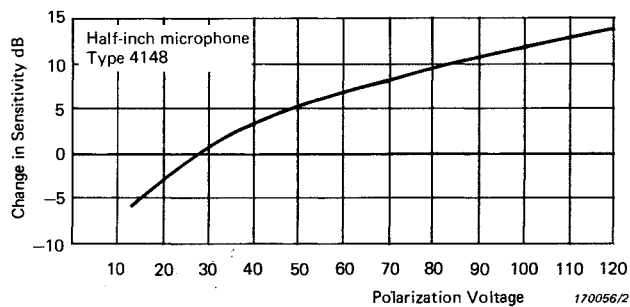

Fig. 6.58. Sensitivity variation of half-inch microphone Type 4148 at 250 Hz as a function of polarization voltage

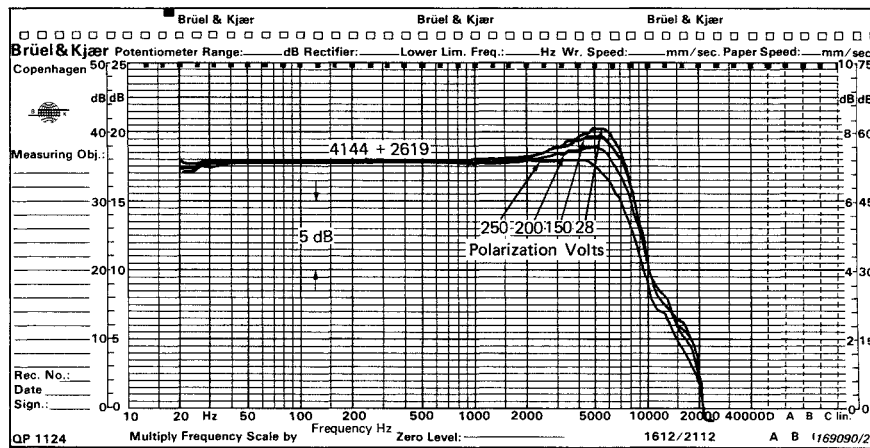

Fig. 6.59. Effect of polarization voltage on frequency response of one-inch microphone Type 4144

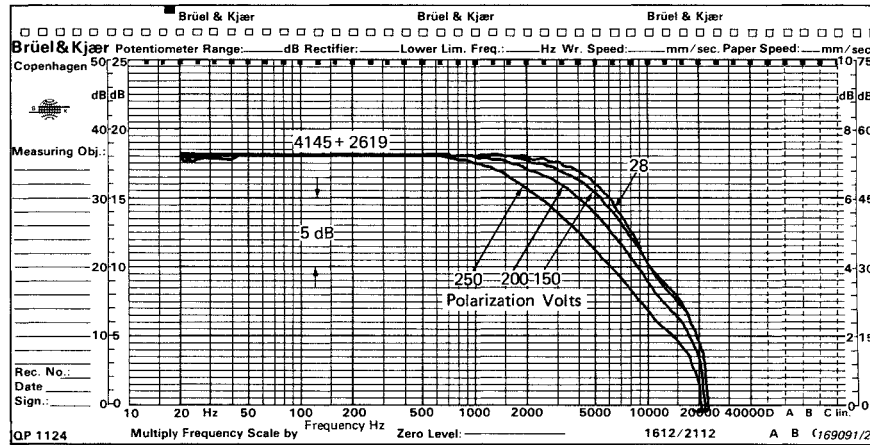

Fig. 6.60. Effect of polarization voltage on frequency response of one-inch microphone Type 4145

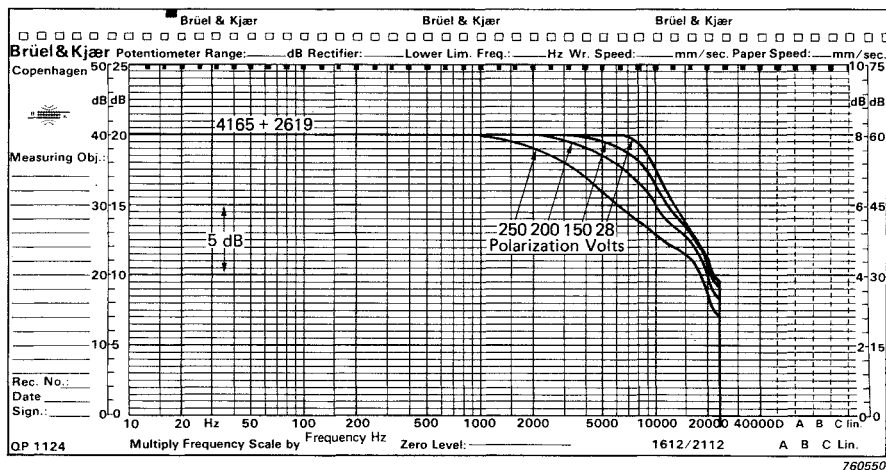

Fig. 6.61. Effect of polarization voltage on frequency response of half-inch microphone Type 4165

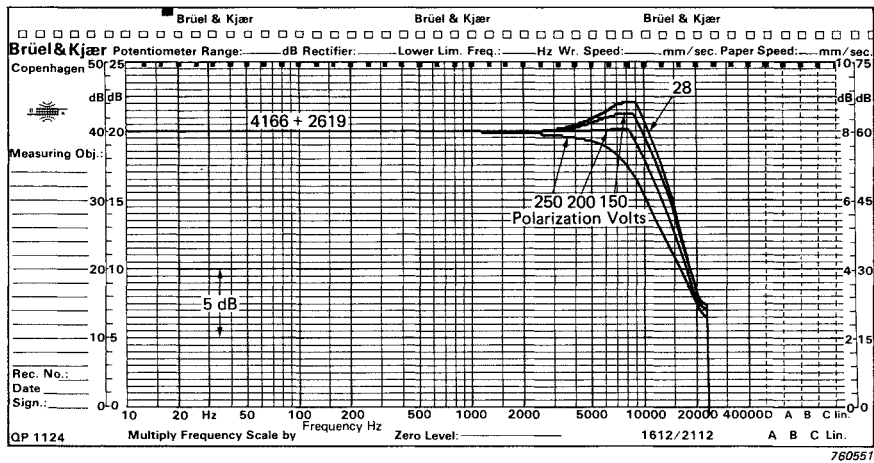

Fig. 6.62. Effect of polarization voltage on frequency response of half-inch microphone Type 4166

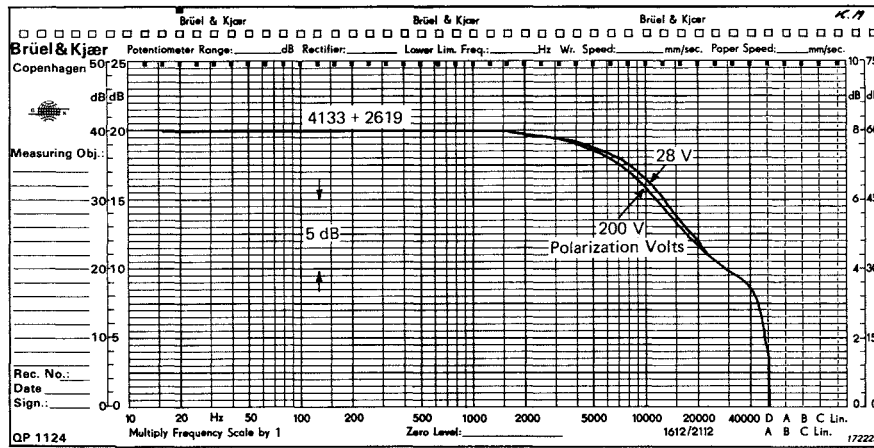

Fig. 6.63. Effect of polarization voltage on frequency response of half-inch microphones Types 4133 and 4149

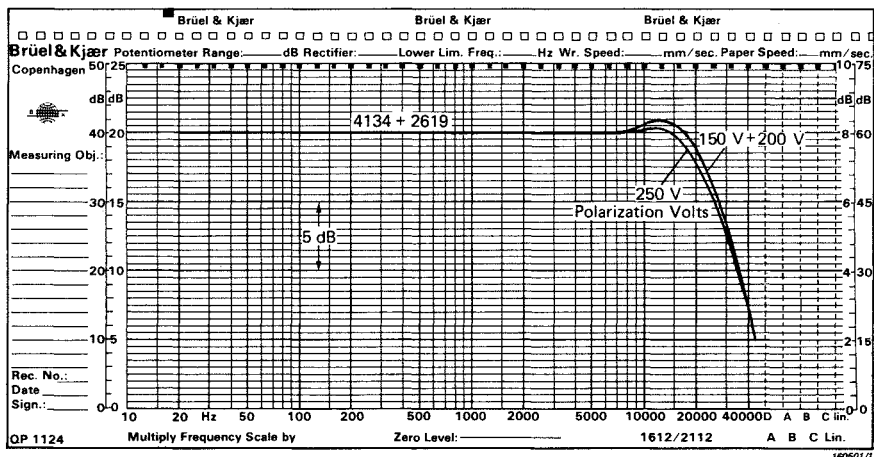

Fig. 6.64. Effect of polarization voltage on frequency response of half-inch microphone Type 4134

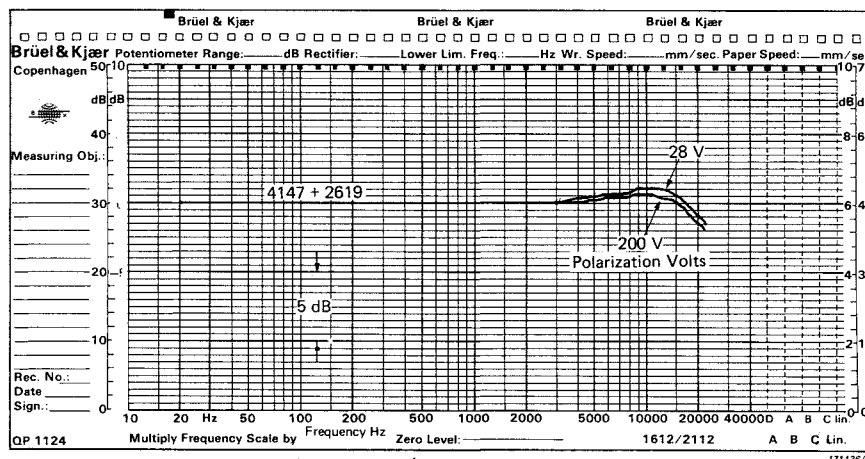

Fig. 6.65. Effect of polarization voltage on frequency response of half-inch microphone Type 4147

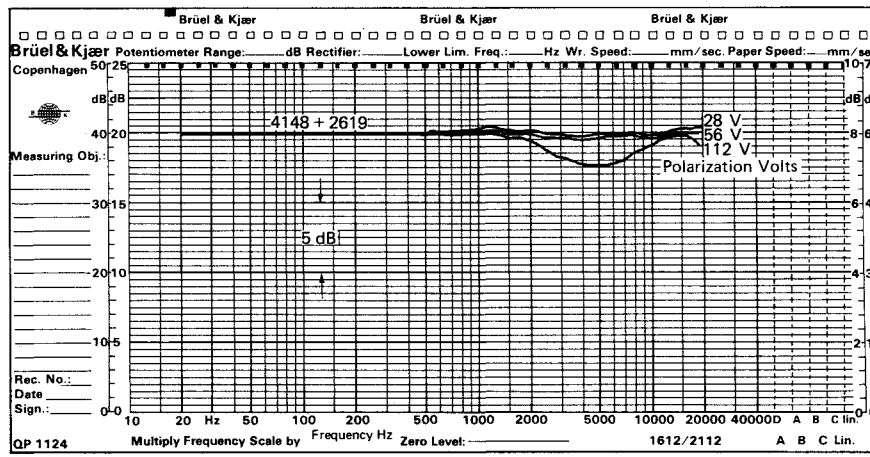

Fig. 6.66. Effect of polarization voltage on frequency response of half-inch microphone Type 4148

6.9. LEAKAGE RESISTANCE

The leakage resistance of a condenser microphone must be at least 1000 times higher than the resistance in the charging circuit of the preamplifier. This is to prevent attenuation of the polarization voltage on the microphone. Usually, the charging resistance is $10^9 \Omega$ or higher, so the leakage resistance of the cartridge must be above $10^{12} \Omega$.

The insulators in the cartridges are from pure quartz, or synthetic ruby or sapphire which has been treated with silicon to eliminate humidity problems. The construction used makes this part of the cartridge non-critical. The main leakage path is normally due to ion current across the air gap between the diaphragm and backplate. Advanced cleaning and polishing techniques used for the electrodes give high leakage resistance. This resistance is verified in the manufacturing process to be higher than $5 \cdot 10^{15} \Omega$ at 86% relative humidity for the one-inch and half-inch microphones ($> 50\%$ for 1/4" and 1/8" microphones).

6.10. LONG-TERM STABILITY

The sensitivity of a microphone will increase slightly over a long period of time even if no mishandling or damage has occurred. This change is due to creep of the diaphragm, so that a reduction of diaphragm tension takes place. The rate of change of sensitivity is greater at elevated temperatures and at 150°C the rate of change is specified to be better than 1 dB per two hours for all one-inch and half-inch microphone types except the quartz coated microphones Types 4165, 4166 and 4149. Variation of the stability as a function of temperature is shown in Fig.6.67. By extrapolation to room temperature, this gives a stability of the order 1 dB per 1000 years for all types except the 4165 and 4166 which is of the order of 1 dB per 600 years and the 4149 which is of the order 1 dB per 200 years. Further details are contained in the B & K Technical Review No.2, 1969.

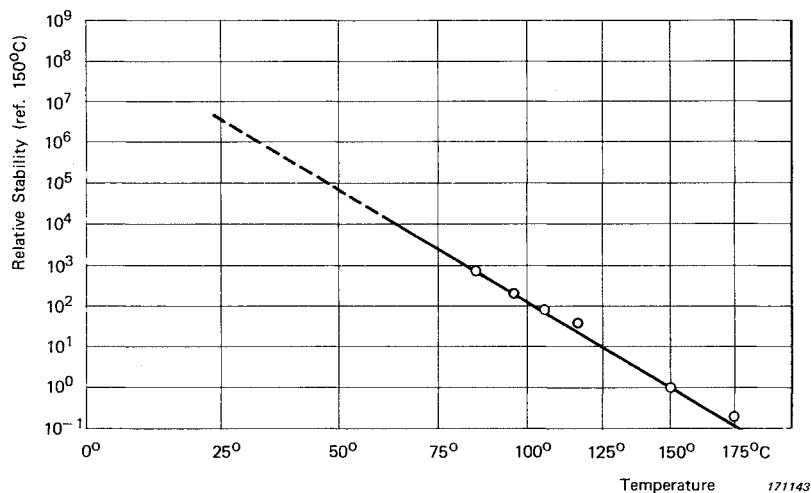

Fig. 6.67. Long-term variation of sensitivity with ambient temperature

External conditions, such as mechanical shocks and temperature transients, can influence the sensitivity of a condenser microphone. The resulting changes in sensitivity are generally very small and their directions are randomly distributed. As a general rule, microphones with high diaphragm tension are the most stable, and should therefore be chosen when laboratory standard microphones are needed. Many years of experience in microphone calibration have shown that calibration reproducibility is better than $\pm 0,02$ dB for Type 4144 when the microphones are kept at room temperature (varying in a range of less than 8 to 10°C); the figure includes both microphone and calibration equipment instability. The one-inch microphones Types 4144, 4145 and 4160 are all well suited for use as laboratory standard microphones. In the half-inch microphone range, Types 4133 and 4134 should be preferred for this purposes.

6.11. EFFECT OF TEMPERATURE

Elevated temperature operation increases the rate of change in sensitivity, as mentioned in section 6.10. The smaller, reversible changes in sensitivity and frequency response which occur in operation at elevated temperatures, are shown in Figs.6.68 to 6.73.

The changes are mainly due to varying diaphragm tension and to changing viscosity and density of air.

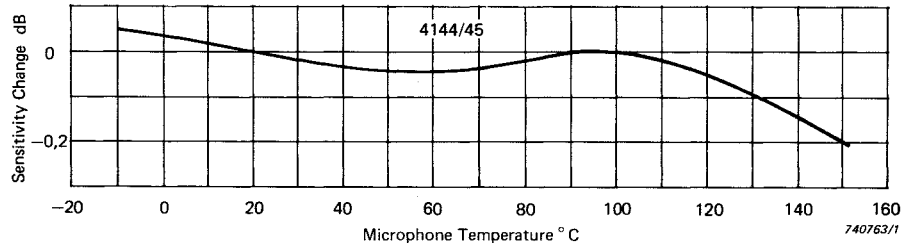
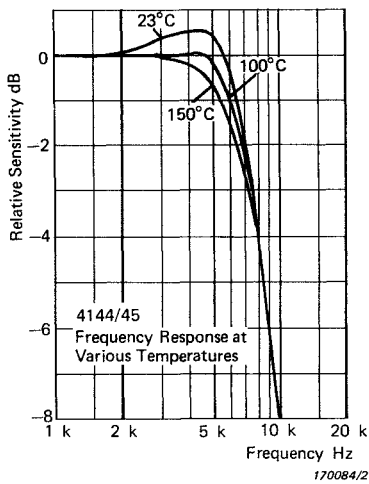

a)

b)

Fig.6.68. Effect of temperature variation on one-inch microphones Types 4144 and 4145

a) Effect on frequency response
b) Typical effect on sensitivity at 250 Hz

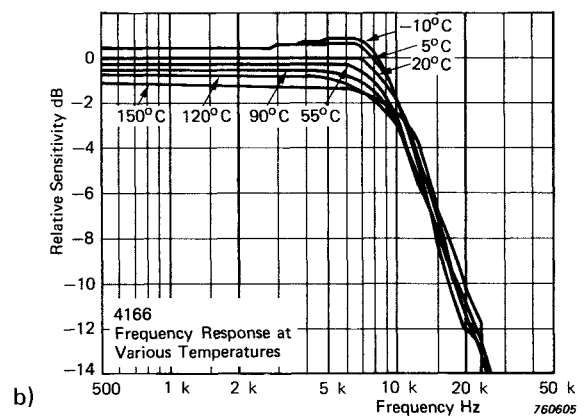
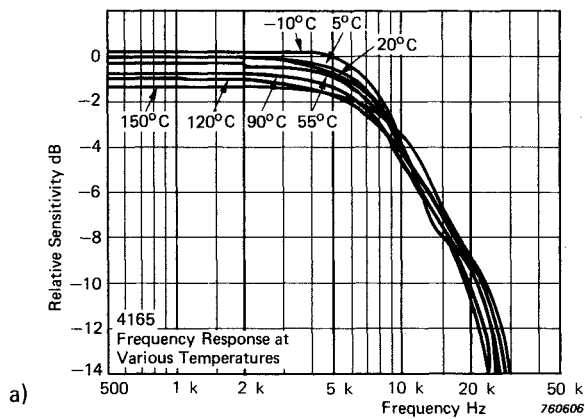

a)

b)

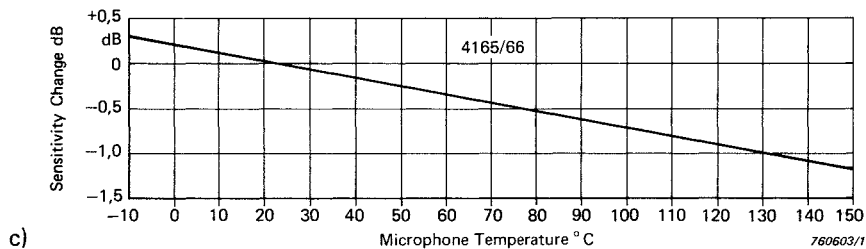

c)

Fig.6.69. Effect of temperature variation on half-inch microphones Types 4165 and 4166

a) Effect on frequency response of Type 4165
b) Effect on frequency response of Type 4166
c) Typical effect on sensitivity at 250 Hz

The materials of the microphones have been chosen to give a thermal matching as close as possible to ideal. At higher frequencies, the air in the gap between the diaphragm and the backplate also has some influence.

The microphones and adaptors to the preamplifiers can be used continuously at temperatures within the range -50°C to $+150^{\circ}\text{C}$ (but not without long-term change in sensitivity, see section 6.10). It is recommended that the microphones should not be used above 150°C , but with intermittent use operation is possible up to 200°C . The insulation of the preamplifier cables should not be exposed to more than 100°C , and the preamplifiers themselves operate within the temperature range -20°C to 60°C (-20°C to 100°C for the 2633).

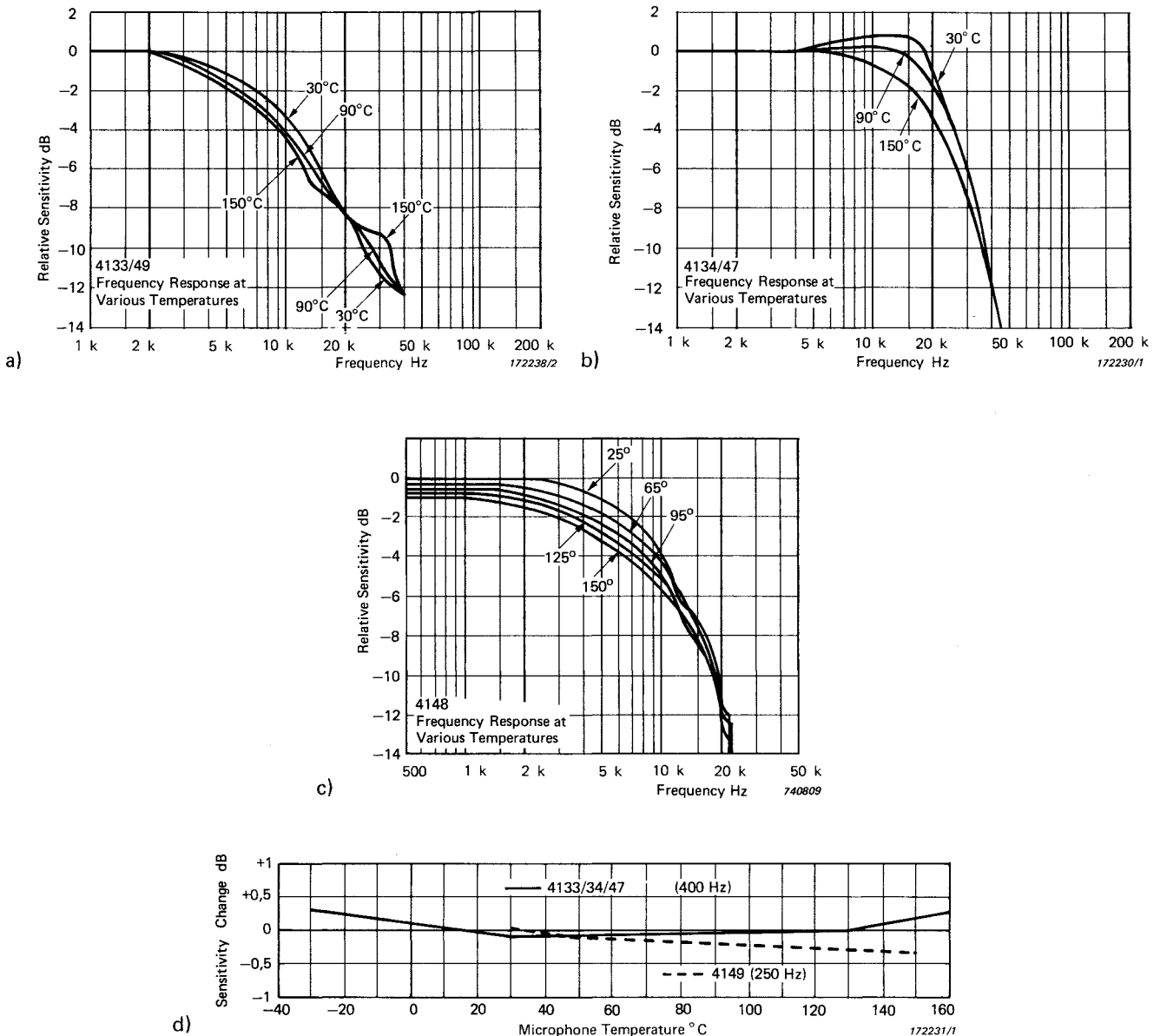

Fig.6.70. Effect of temperature variation on half-inch microphones Types 4133, 4134, 4147, 4148 and 4149

a) Effect on frequency response of Types 4133 and 4149

b) Effect on frequency response of Types 4134 and 4147

c) Effect on frequency response of Type 4148

d) Typical effect on sensitivity at mid-frequency

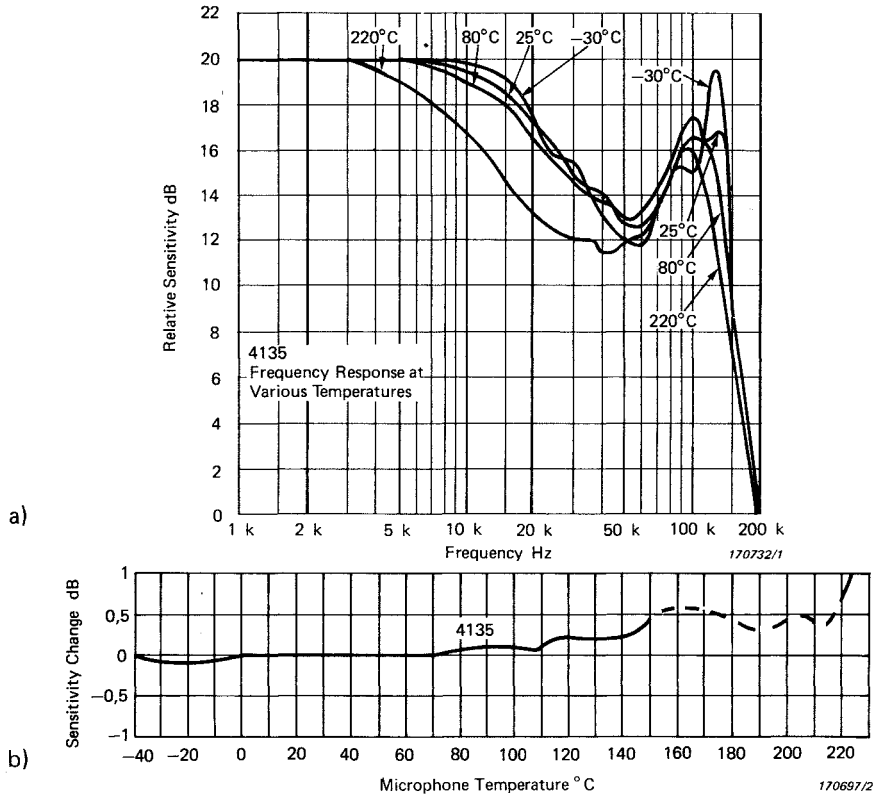

Fig.6.71. Effect of temperature variation on quarter-inch microphone Types 4135
 a) Effect on frequency response
 b) Typical effect on sensitivity at 1 kHz

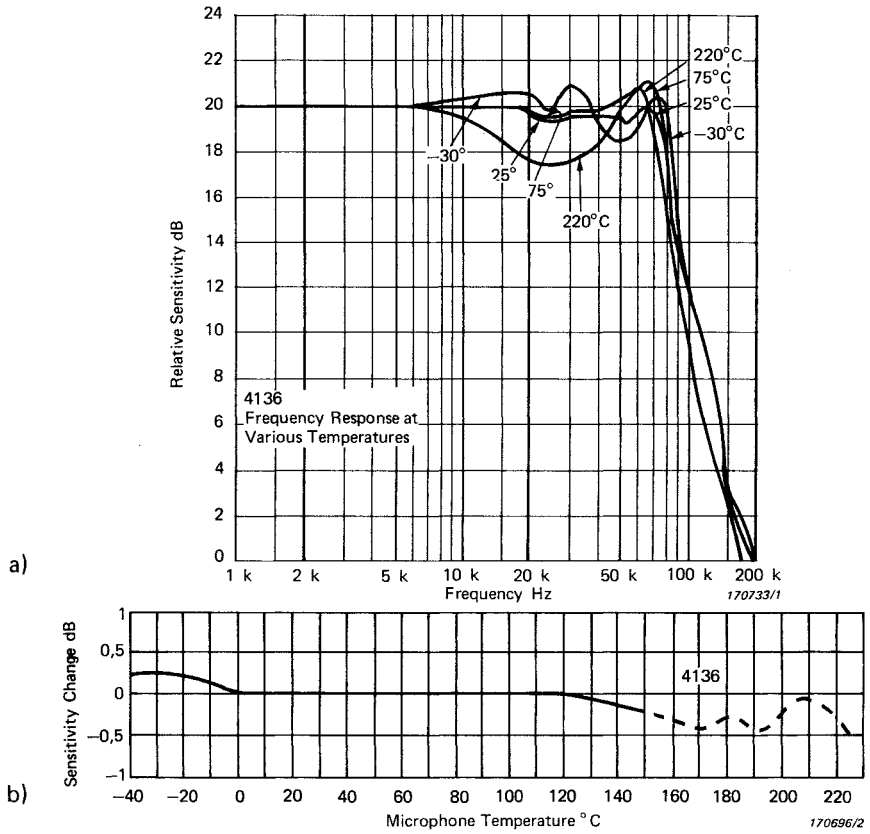

Fig.6.72. Effect of temperature variation on quarter-inch microphone Type 4136
 a) Effect on frequency response
 b) Typical effect on sensitivity at 1 kHz

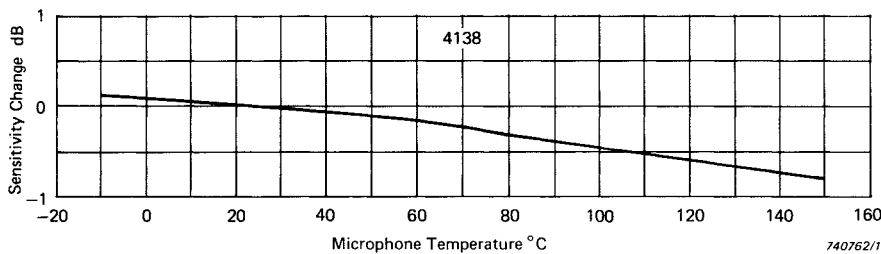
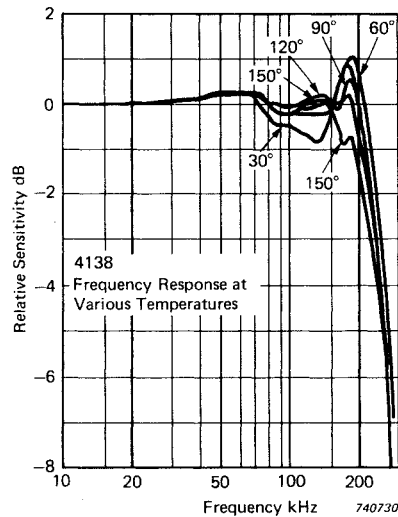

Fig.6.73. Effect of temperature variation on eighth-inch microphone Type 4138
 a) Effect on frequency response
 b) Typical effect on sensitivity at 1 kHz

Because the free-field corrections are primarily a function of wavelength and microphone diameter, they will also be influenced by differences from normal room conditions. A good approximation to the effect of temperature on the free-field correction curves is to change the frequency scale by a factor R which is a function of temperature.

$$R = \sqrt{\frac{273 + t}{296}} \quad (6.7)$$

where R = the factor by which the frequency scale of the free-field correction curves must be multiplied
 t = the temperature of the environment in °C.

Generally, it may be assumed that this influence is insignificant in all but the most precise measurement situations.

6.12. EFFECT OF AMBIENT PRESSURE

One important contributing factor to the stiffness of the vibrating system comes from the air inside the microphone which provides up to 20% (depending on microphone type) of the total stiffness at atmospheric pressure. As the ambient air pressure decreases, so too does the stiffness, with the result that sensitivity of the microphone increases. At low frequencies, the response of the microphone is determined mainly by stiffness. Around the resonance frequency, the response is determined mainly by the energy loss in the vibrating system. This loss is due to air flow in the small gap between the diaph-

ragm and the backplate. The air in the gap also adds to the mass of the diaphragm. This mass changes with static pressure and influences the high frequency response of the microphones.

The effects of static ambient pressure variations on frequency response and sensitivity are shown in Figs.6.74 to 6.78. The variation of sensitivity with static pressure at 250 Hz is given and should not be applied to other frequencies without reference to the corresponding frequency response variations.

For microphones with normal side or back vented static pressure equalization, i.e. all microphones except Type 4147, the effect of varying altitude is very small. A rate of climb of 500 m/s at ground level affects sensitivity by less than 1 dB (see B & K Technical Review No.1, 1960).

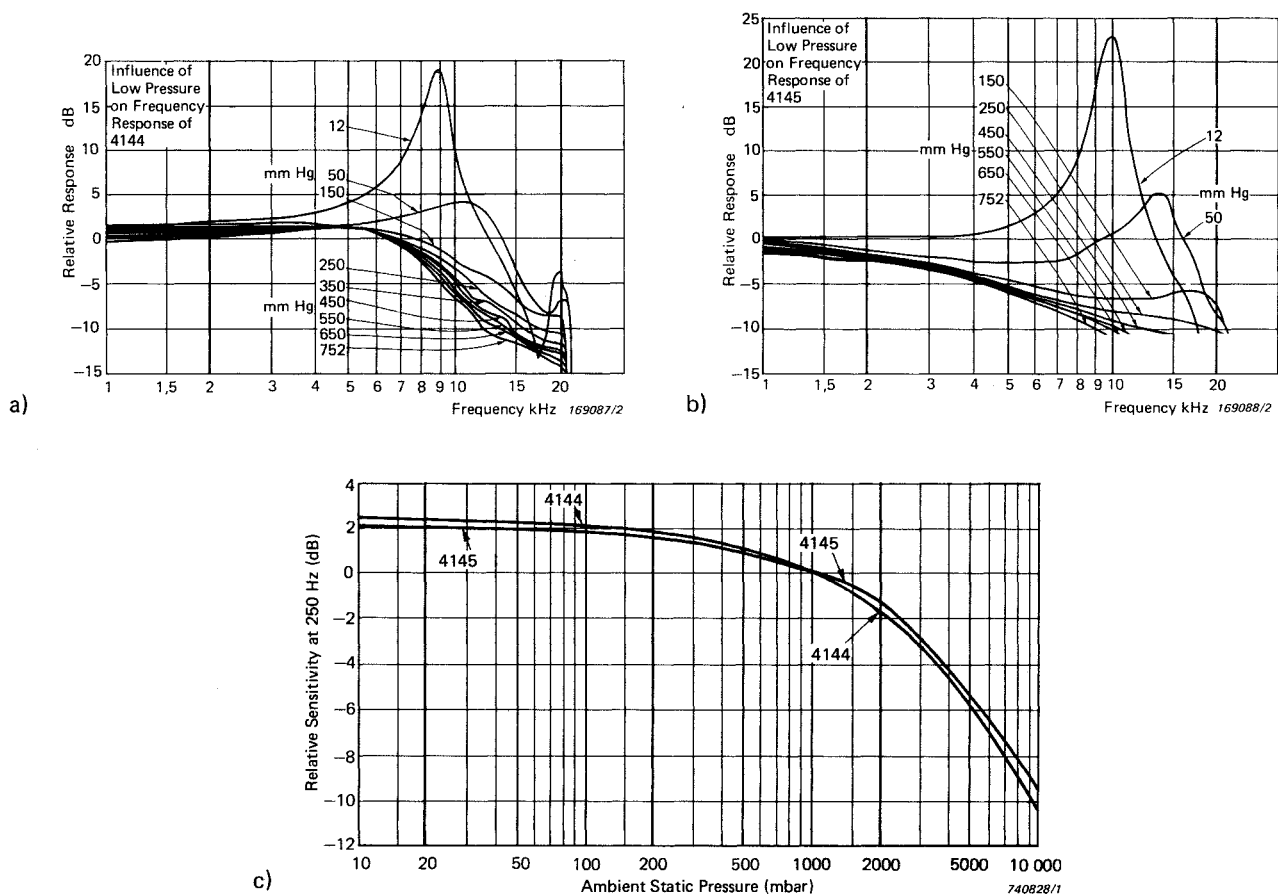
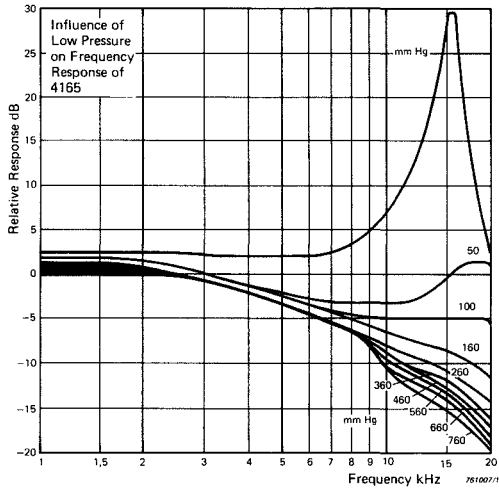
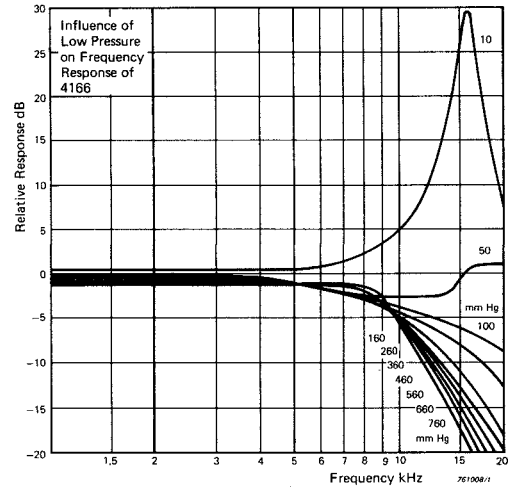

Fig.6.74. Effect of static ambient pressure variation on one-inch microphones Types 4144 and 4145
 a) Effect on frequency response of Type 4144
 b) Effect on frequency response of Type 4145
 c) Variation of sensitivity at 250 Hz

Note that 760 mm Hg = 1013 mbar = 1 atm.



a)



b)

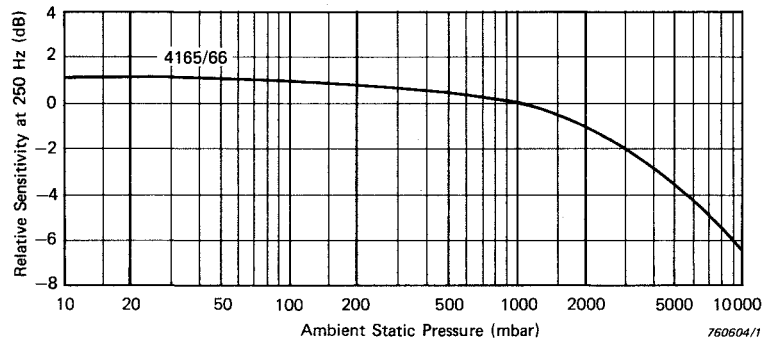

c)

Fig.6.75. Effect of static ambient pressure variation on half-inch microphones Types 4165 and 4166
 a) Effect on frequency response of Type 4165
 b) Effect on frequency response of Type 4166
 c) Variation of sensitivity at 250 Hz

Note that 760 mm Hg = 1013 mbar = 1 atm.

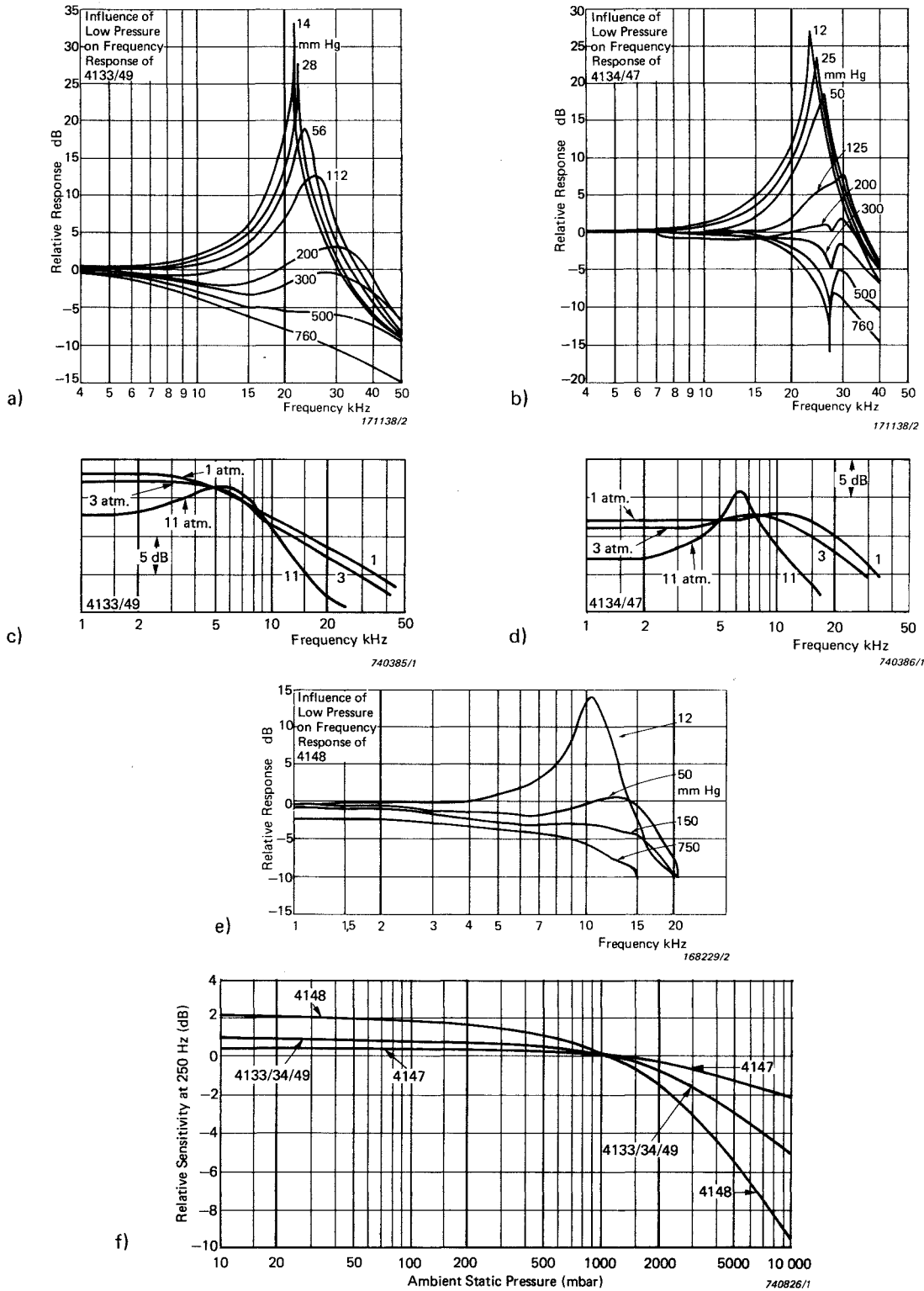

Fig. 6.76. Effect of static ambient pressure variation on half-inch microphones Types 4133, 4134, 4147, 4148 and 4149

- a) Effect on frequency response of Types 4133 and 4149 at low pressure
- b) Effect on frequency response of Types 4134 and 4147 at low pressure
- c) Effect on frequency response of Types 4133 and 4149 at high pressure
- d) Effect on frequency response of Types 4134 and 4147 at high pressure
- e) Effect on frequency response of Type 4148 at low pressure
- f) Variation of sensitivity at 250 Hz

Note that 760 mm Hg = 1013 mbar = 1 atm

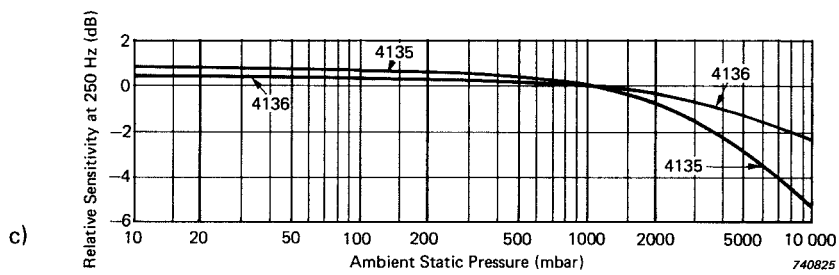
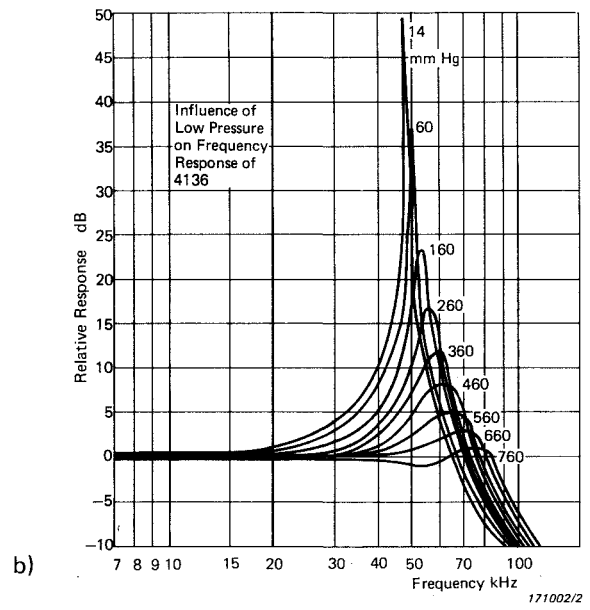
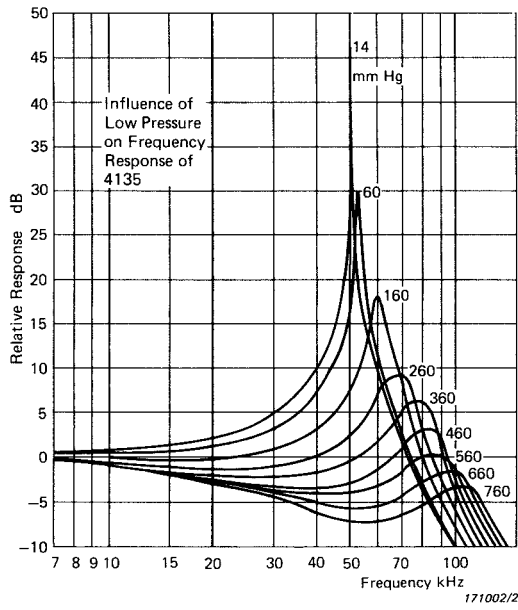

Fig. 6.77. Effect of static ambient pressure variation on quarter-inch microphones Types 4135 and 4136
 a) Effect on frequency response of Type 4135
 b) Effect on frequency response of Type 4136
 c) Variation of sensitivity at 250 Hz

Note that 760 mm Hg = 1013 mbar = 1 atm

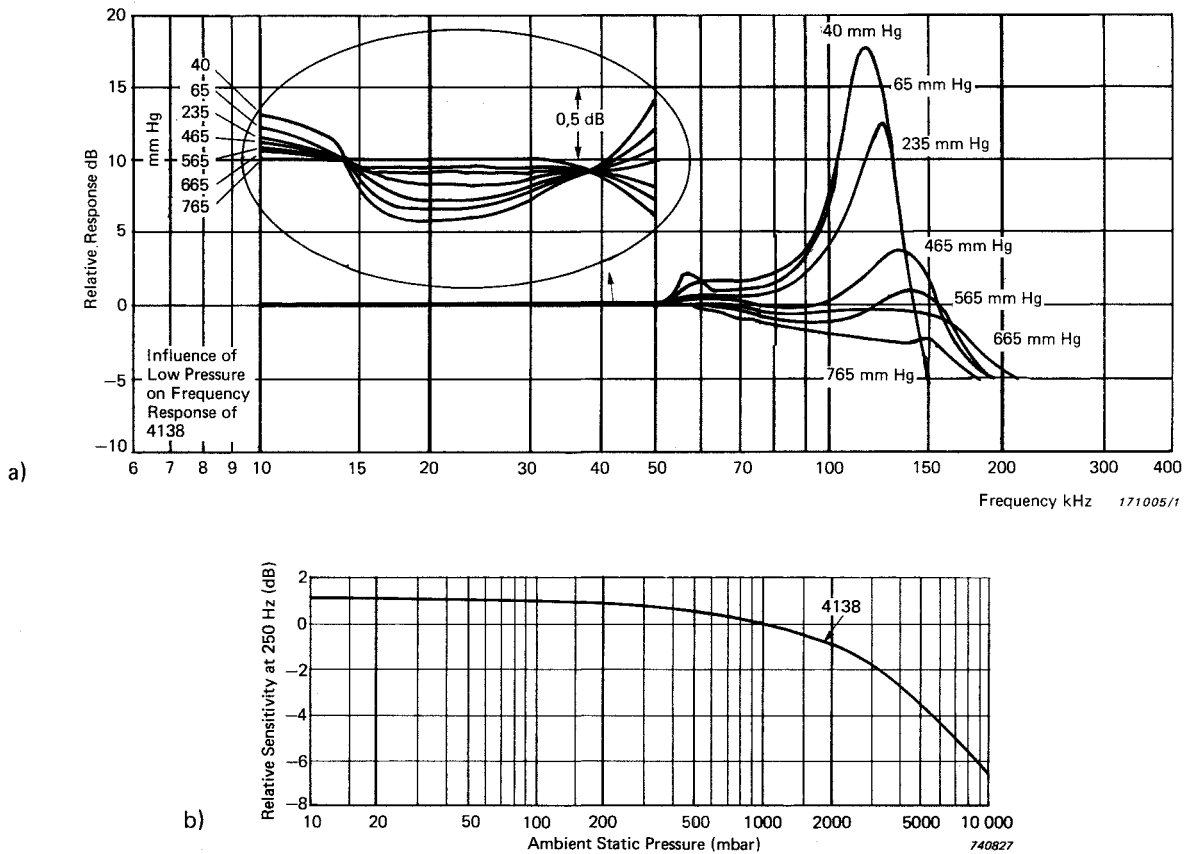

Fig.6.78. Effect of static ambient pressure variation on eighth-inch microphone Type 4138
 a) Effect on frequency response
 b) Variation of sensitivity at 250 Hz

Note that 760 mm Hg = 1013 mbar = 1 atm.

6.13. EFFECT OF HUMIDITY

Providing no condensation occurs, the effect of high humidity on the microphones is generally negligible. Half-inch microphones Types 4165 and 4166, however, exhibit a reversible short term sensitivity change dependent on humidity as shown in Fig.6.79. The change is due to moisture absorption by the protective quartz coating on the diaphragm of these microphones.

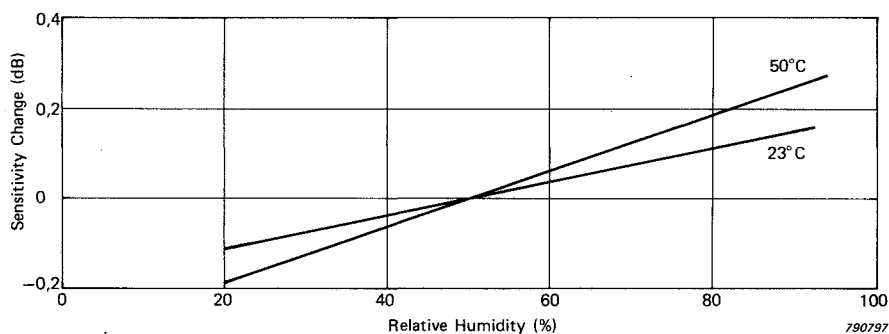

Fig.6.79. Short-term reversible effect of humidity on half-inch microphones Types 4165 and 4166

Once condensation has taken place there is a temporary risk of electrical noise due to intermittent short circuiting of the diaphragm and backplate. It is recommended that the preamplifier power supply is switched off if this occurs. When stable ambient conditions are regained, the condensed water will evaporate through the pressure equalization vent. The possibility of condensation is greatest when changing from an environment which is warm and humid to one which is significantly colder. In general, the use of desiccators during storage is not necessary but the one-inch microphones should be fitted with the silica gel cap. The silica gel should be maintained in its blue (dry) state by placing it in a warm dry environment (not exceeding 135°C) whenever the gel begins to turn pink.

6.14. EFFECT OF VIBRATION

The influence of vibration is a maximum when it is applied perpendicular to the diaphragm. Severity is determined mainly by the mass of the diaphragm. A vibration amplitude of 1 m/s² RMS perpendicular to the diaphragm produces an output equivalent to a sound pressure level as given in Table 6.6.

Microphone Type		Equivalent Sound Pressure Level for 1 m/s ² RMS normal to the diaphragm (dB re 20 µPa)
One-Inch	4144, 4145	67
Half-Inch	4133, 4134 4147, 4149	67
	4148	57
	4165, 4166	60
Quarter-Inch	4135	59
	4136	69
Eighth-Inch	4138	58

810088

Table 6.6. Effect of vibration

6.15. EFFECT OF MAGNETIC FIELDS

The influence of a magnetic field on the microphones is a function of the vector field strength and therefore depends on both the magnitude of the field, and its orientation to the axis of the microphone. The effect can be measured using a field strength of 80 A/m (recommended by IEC and ANSI), and may be expressed as an equivalent sound pressure level. For a field strength of 80 A/m at 50 Hz the field-induced SPL is normally greatest when the field direction is perpendicular to the microphone diaphragm. Higher frequency field components only become dominant at field strengths greater than 500 to 1000 A/m.

When measurements are to be carried out in strong magnetic fields, the influence of the field should be checked using a pistonphone, calibrator or silica gel cap to acoustically shield the microphone. The meter reading should then drop by 10 to 15 dB if the effect due to the magnetic field is to be assumed negligible. If the damping achieved is considerably less than this and moving the microphone results in a variation in the meter reading, the magnetic field will affect the measurement accuracy.

Typical field-induced equivalent SPL's for a magnetic field strength of 80 A/m at 50 Hz in the direction which has most effect on the microphone are given in Table 6.7.

Microphone Type		Equivalent Sound Pressure Level for 80 A/m (50 Hz) magnetic field (dB re 20 μ Pa)	
		Typical value	Range
One-Inch	4144, 4145	18	4 – 24
Half-Inch	4133, 4134 4147, 4149	20	6 – 34
	4148	28	10 – 38
	4165, 4166	30	10 – 40
Quarter-Inch	4135	30	10 – 42
	4136	38	18 – 46
Eighth-Inch	4138	40	30 – 50

810089

Table 6.7. Effect of a magnetic field of 80 A/m (1 oersted) at 50 Hz

A survey was carried out at Brüel & Kjær in order to estimate the order of magnitude of the magnetic fields around typical machines. The maximum values measured 25 cm away from the machine were found to lie typically between 1 and 32,5 A/m. An exception was a point-soldering machine where a maximum of 3750 A/m was measured.

Typical magnetic fields measured in a power plant are given in Table 6.8.

Measurement Location	Max. Magnetic Field Strength (A/m)
13 kV to 120 kV transformer 1, at 1 m	110
1 m from 120 kV output cable, transformer 1	200
13 kV to 5 kV transformer at 1 m	14
2 m from coils of 30 kV output	350
1 m from generator 1, machine room	56
1 m from 13 kV output cable of generator 1	1250

820008

Table 6.8. Example of magnetic fields measured in a power plant

6.16. EFFECT OF SOLAR RADIATION

Under very special measuring conditions where solar radiation strikes directly on to the diaphragm, the heat received could be expected to have a small influence on the characteristics of the microphone. Measurements have shown that the influence is far below 0,1 dB. When the microphone is fitted with its normal protecting grid, the influence becomes extremely small. A full report is contained in the B & K Technical Review No.1, 1974, "Influence of Sunbeams striking the Diaphragms of Measuring Microphones".

7. CALIBRATION

7.1. GENERAL

The microphone cartridges are calibrated at the factory and this calibration will normally be valid indefinitely (see section 6.10). Recalibration may be desirable after special applications, however, for example after operation at high temperatures for long periods of time, or to check that no permanent change has occurred after a particularly arduous application. For such a thorough calibration, both sensitivity at a fixed frequency and relative frequency response of the microphone must be calibrated, and therefore a combination of techniques is usually required to obtain a complete calibration. However, for general routine calibration a simple check of sensitivity is adequate, since as long as the low frequency (250 Hz to 1 kHz) sensitivity remains unchanged there are no good reasons for expecting an alteration in frequency characteristics.

Microphone calibration methods may be divided into two groups: the laboratory methods and the field calibration methods. The latter have already been described in section 4.3 where the following methods are mentioned:

- a) Pistonphone Type 4220
- b) Sound Level Calibrator Type 4230
- c) Measuring Amplifier reference voltage — Microphone K-factor
- d) Insert Voltage Calibration
- e) Electrostatic Actuator

This chapter will therefore deal mainly with laboratory calibration methods, i.e. reciprocity calibration, use of an electrostatic actuator and high pressure calibration. In conclusion, the calibration performed at the B & K Factory will be briefly discussed.

7.2. RECIPROCAL CALIBRATION

This is an absolute calibration method based on the Reciprocity Principle. The calibrated microphones are used both as transmitters and receivers. The Reciprocity Calibration Apparatus Type 4143 provides calibration facilities for condenser microphones to the strictest laboratory standards, such as IEC Publication 327. Further details on the method and its practical application may be found in the Instruction Manual for the 4143. However, it should be noted that the method is only applicable in practice at fixed frequencies and does not allow swept frequency response measurements.

7.3. ELECTROSTATIC ACTUATOR

With condenser microphones having a plane, metallic diaphragm (which is the case with the B & K condenser microphones), the diaphragm may be influenced by electrostatic forces in a way which is similar to the action of sound waves. This is done by placing a rigid metallic grid in close proximity to the diaphragm and applying an alternating test voltage between them.



Fig.7.1. Electrostatic Actuators UA 0023 (one-inch) and UA 0033 (half-inch)

This is a very convenient way to establish an accurate "sound field" which is much easier to produce than the equivalent acoustical field.

The B & K Electrostatic Actuators UA 0023 for one-inch microphones and UA 0033 for half-inch, and smaller microphones fitted with a suitable adaptor, are available for investigation of frequency response (see Fig.7.1). They are also included with the Reciprocity Calibration Apparatus 4143.

The Actuator is placed on the microphone cartridge which should be held with its diaphragm horizontal. The Actuator has three glass studs which contact the periphery of the cartridge and provide spacing of approx. 0,5 mm between the Actuator grid and the diaphragm of the cartridge. The Actuator is either used directly on the microphone cartridge or the microphone must be fitted with an adaptor, as shown in Table 7.1.

As the influence of the distance between the Actuator grid and the microphone diaphragm is critical for the electrostatic attraction force, absolute calibration is very difficult and the method will be useful only for relative measurements such as frequency response measurements.

The curves obtained by the electrostatic actuator method represent the microphone pressure response over a wide frequency range. The curves are used to find the microphone free-field or random response by adding the relevant correction to the actuator response (see section 6.2). However, the actuator response differs from the coupler response at the high frequencies and, at low frequencies the method does not account for the influence of the pressure equalization system of the microphone and should therefore not be used below approx. 5 times the microphone lower limiting frequency (see section 6.2.2).

Microphone Size	Adaptor to UA 0023	Adaptor to UA 0033
One-inch	none required (DB 0225) * *	none required DB 0264 DB 0900
Half-inch		
Quarter-inch		
Eighth-inch		

* Not recommended

740773/1

Table 7.1. Adaptors required for microphones when using Electrostatic Actuators UA 0023 and UA 0033. Parentheses indicate that a more suitable alternative exists

With the Reciprocity Calibration Apparatus Type 4143, the signal from the generator is amplified by 20 dB and is applied to the Actuator together with an 800 V DC polarization voltage. With a generator voltage of 10 V RMS (i.e. an AC component of 100 V RMS applied to the Actuator), the equivalent sound pressure level experienced by the microphone diaphragm will be approx. 104 dB SPL at the generator frequency.

When no DC component is used, the excitation frequency is twice the tuned frequency.

Besides standard frequency response measurements, the 4143 also allows the response curve to be plotted with great resolution (better than 0,005 dB) using the built-in precision comparator. For details reference should be made to the 4143 Instruction Manual.

The Rain Cover UA 0393 is designed to be mounted on B & K half-inch condenser microphones for outdoor use. A built-in electrostatic actuator allows calibration checks. The Rain Cover can be delivered calibrated at the factory together with a half-inch microphone. Application of 215 V AC will give an equivalent SPL of 90 ± 1 dB. In this case, it is important that the Rain Cover is not removed from the microphone, since the calibration spacing between the microphone diaphragm and the actuator grid would be lost. This will result in an error of up to $\pm 0,3$ dB compared with the factory calibration.

7.4. HIGH PRESSURE CALIBRATION

The behaviour of condenser microphones at very high dynamic pressure as regards linearity, distortion, etc., may be of interest for special applications. The High Pressure Microphone Calibrator Type 4221 allows measurements at levels up to 162 dB re $20 \mu\text{Pa}$ in continuous operation. In conjunction with the Gating System Type 4440, levels of up to 172 dB may be reached (max. pulse length 15% of repetition period). In addition, a low frequency coupler allows measurements down to 0,01 Hz. The 4221 is factory calibrated and delivered with all necessary calibration data. Full details may be found in the 4221 Instruction Manual.

7.5. FACTORY CALIBRATION

B & K now has more than 30 years' experience in calibrating microphones. During this time, the accuracy and reproducibility have been proved, and today the IEC Recommendations 327 is complied with. This states an absolute accuracy better than $\pm 0,05$ dB for B & K's factory standard microphones. Reproducibility better than $\pm 0,02$ dB, and for several years there has been a very good agreement with international calibration laboratories, such as the Danish Technical University and the American National Bureau of Standards.

Before leaving the factory, the microphone cartridges are submitted to an extensive ageing and calibration procedure. Before starting the ageing procedure, the microphone sensitivity is checked and adjusted to a lower value than the nominal sensitivity, since sensitivity will be increased by the ageing procedure. The microphone is then submitted to a full calibration procedure. All important parameters are individually measured and indicated on the calibration chart together with the frequency response (Fig.4.4).

7.5.1. Sensitivity

The open circuit sensitivity, which is the sensitivity when the microphone is not loaded by any preamplifier, stray capacitance, etc., is measured at 250 Hz by comparison with a standard microphone using insert voltage calibration techniques and a specially deve-

loped pistonphone. In order to minimize the effect of production variations in microphone equivalent volume and the volume between the grid and the diaphragm, the internal volume of the pistonphone is twice that of the Type 4220 Pistonphone. Since other dimensions of the calibration pistonphone are similar to those of the 4220, the calibration level is 118 dB.

The microphones used as standards for the calibration are calibrated once a year using the reciprocity calibration method in agreement with IEC Publication 327 (accuracy better than 0,05 dB). They are also checked by external authorities.

7.5.2. Cartridge Capacitance

The capacitance indicated on the calibration chart is measured at 250 Hz with the nominal polarization voltage.

7.5.3. Frequency Response

The individual frequency response curves are measured by an electrostatic actuator method. For free-field microphones, the free-field response is obtained individually by adding the free-field correction to the actuator response. For microphones best suited for diffuse field measurements, the diffuse field response, obtained in the same way, is also added.

7.5.4. Low Frequency Limit (−3 dB point)

All microphones except 4147

The lower limiting frequency of each microphone is checked to be within the specified limits and, for some types, is given on the calibration chart. This is made (except for Type 4147) using the High Pressure Microphone Calibrator Type 4221. The electrostatic actuator is not suitable for this purpose.

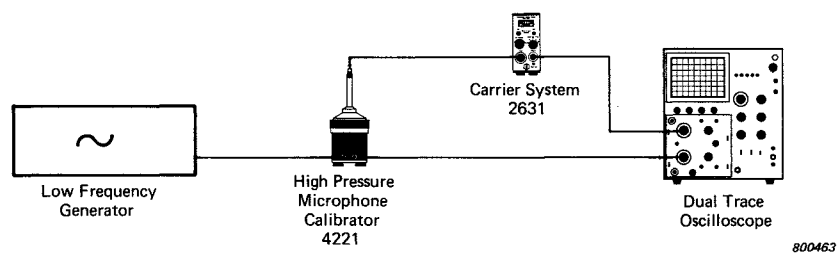

Fig.7.2. Factory calibration of lower limiting frequency for all microphone types except Type 4147

The system used in the factory calibration of lower limiting frequency is shown in Fig.7.2. The microphone is placed inside the low frequency coupler of the High Pressure Microphone Calibrator Type 4221. A low frequency generator provides the excitation voltage and the VOLTMETER output of the 4221 is monitored on a dual-trace oscilloscope to ensure constant sound pressure in the coupler. The output of the Carrier System Type 2631 is fed to the other channel of the oscilloscope. The test frequency is reduced until the oscilloscope indicates a level drop of 3 dB from the high frequency output.

Low frequency microphone 4147

Type 4147 has a lower limiting frequency in the range 10^{-3} Hz to 5×10^{-3} Hz. Since direct measurements at such lower frequencies are extremely difficult and would take considerable time, the time constant of the pressure equalization system (which determines the low frequency limit) is measured. Assuming that pressure is the same on both sides of the diaphragm, the external pressure is suddenly increased by ΔP_0 at time $t = 0$ to become P_0 . The internal pressure P_i will tend exponentially to P_0 .

$$P_i = P_0 - \Delta P_0 \exp. (-t/\tau) \quad (7.1)$$

where τ is the time constant of the microphone's static pressure equalization system. Hence, the pressure difference across the diaphragm, ΔP , is:

$$\Delta P = \Delta P_0 \exp. (-t/\tau) \quad (7.2)$$

Since the output voltage of the microphone when connected to the Carrier System is proportional to the pressure difference:

$$\Delta E = E_0 \exp. (-t/\tau) \quad (7.3)$$

where E_0 is the output voltage at $t = 0$, just after the application of the pressure increment.

Hence:

$$\frac{\Delta E}{E_0} = \exp. (-t/\tau) \quad (7.4)$$

$$20 \log_{10} \left(\frac{\Delta E}{E_0} \right) = \frac{-20 t}{\tau} \log_{10} e$$

$$\therefore \frac{\Delta E}{E_0} \text{ in dB} = -8,686 \frac{t}{\tau}$$

The slope v (dB/s) of the 2631 output plotted on a logarithmic scale is:

$$v = 20 \log_{10} \left(\frac{\Delta E}{E_0} \right) \frac{1}{t} \quad (7.5)$$

Hence:

$$\tau = \frac{-8,686}{v} \text{ S} \quad (7.6)$$

The lower limiting frequency —3 dB point (f_L) can then be obtained as in an equivalent electrical circuit as:

$$f_L = \frac{1}{2\pi\tau} \text{ Hz} \quad (7.7)$$

The principle of the factory calibration method used for the Type 4147 microphone is shown in Fig.7.3. The microphone is fitted to the 2631 Microphone Carrier System via the Adaptor UA 0271 and the output of the Carrier System taken to a Level Recorder with 10 dB Range Potentiometer and set for DC response. Coupler volume is approx. 6 cm^3 . A manometer is used to give a direct reading of the pressure change (where this is required) but principally to ensure that the pressure during the test remains constant. It provides the additional benefits

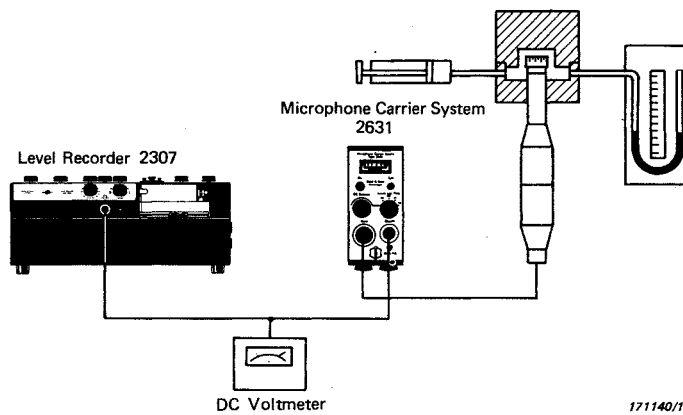

Fig.7.3. Calibration of lower limiting frequency of half-inch microphone Type 4147

of increasing the equivalent volume of the system and suppressing the effect of heat conduction between the enclosed air and the inside walls of the coupler after the increment has been applied.

Before the pressure increment is applied, the DC level of the 2631 must be carefully balanced to zero in order to ensure that a linear decay curve results. The resulting decay curve is shown in Fig.7.4 from which the microphone's lower limiting frequency can be verified as $1,02 \cdot 10^{-3}$ Hz from its time constant of approx. 156 s. Specifications for the 4147 demand a time constant for static pressure equalization between 30 s and 160 s.

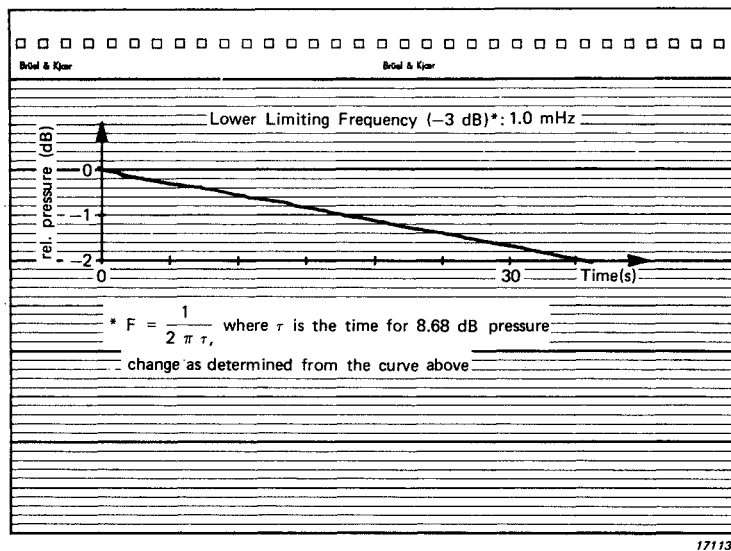

Fig.7.4. Lower limiting frequency calibration chart of half-inch microphone Type 4147

7.5.5. Measurement of Equivalent Volume

An individual calibration of equivalent volume is given for Type 4144 and 4160 Microphones. The equivalent volume is measured by means of a tuned acoustical circuit. When the Type 4144 cartridge is to be used in coupler measurements, it should normally be fitted with the Adaptor Ring DB 0111. This ring forms the standardized cavity in front of the microphone diaphragm, whose diameter is 18,6 mm and depth 1,95 mm.

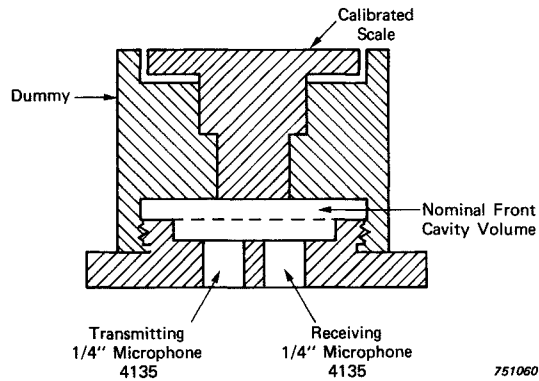

Fig.7.5. Coupler for equivalent volume measurement

Such an adaptor ring is used in the calibration of microphone equivalent volume, and the volume quoted on the calibration chart is the total equivalent volume below the front plane of the coupler ring minus the nominal volume of the cavity (530 mm^3).

Measurement is made using a special coupler as shown in Fig.7.5. A quarter-inch Condenser Microphone Type 4135 is used as a sound source while the resulting sound pressure is measured by another 4135. The 4144 (fitted with Adaptor Ring DB 0111) is first placed onto the top of the coupler and the excitation signal (250 Hz frequency) is adjusted until the output of the receiver microphone is equal to a chosen reference value.

The 4144 is then replaced by an adjustable dummy. The calibrated centre screw is adjusted until the output of the receiver microphone is again equal to the reference value. From the reading on the calibrated scale of the dummy, the equivalent volume of the microphone is derived, taking into account heat conduction so that the equivalent volume indicated on the calibration chart refers to purely adiabatic conditions.

8. PREAMPLIFIERS

This chapter deals with the characteristics of the B & K preamplifiers which are intended for use with the condenser microphone cartridges. The three preamplifiers discussed here are the quarter-inch Preamplifier Type 2633, the half-inch Preamplifier Type 2619 and the one-inch Insert Voltage Preamplifier Type 2627.

The Microphone Carrier System Type 2631 has some advantageous features, particularly when low frequency measurements are considered, but since the principle of operation with a condenser microphone is quite different, the 2631 is treated separately in its own Instruction Manual.

8.1. DESCRIPTIONS

8.1.1. General

The preamplifiers are delivered in a mahogany case which contains the adaptors listed in the specifications in section 1.2 (Note that half-inch preamplifier Type 2619 can also be delivered without accessories, see section 8.1.3). The preamplifiers may be connected directly to the PREAMP. INPUT socket of any of the B & K Measuring Amplifiers or Analyzers. Table 8.1 shows the connections to the preamplifiers viewed from the soldering side of the pins (external view of mating socket). The mating socket is JJ 0703 (panel mounting) or JJ 0704 (cable mounting).

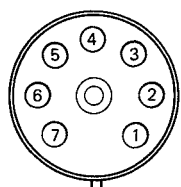

800250

Connection of pin no.	Preamplifier Type		
	2633	2619	2627
1	Ground	Heater ground	Heater and signal ground
2	200 V DC	200 V DC	200 V DC
3	Not connected	Ground	Microphone Thread
4	Signal	Signal	Signal
5	120 V DC	120 V DC	120 V DC
6	Not connected	28 V DC	Not connected
7	Not connected	Heater 12 V DC	Heater 12 V DC
casing	Outer Screen	Outer Screen	Outer Screen

740770/2

Table 8.1. Pin designations. External view of matching socket JJ 0703 or JJ 0704

8.1.2. Quarter-inch Preamplifier Type 2633

Dimensions of the Quarter-inch Preamplifier are shown in Fig.8.1. The input impedance of the preamplifier is $> 50 \text{ G } \Omega$ in parallel with $0,25 \text{ pF}$ up to 60°C , falling to approximately $5 \text{ G } \Omega$ in parallel with $0,25 \text{ pF}$ at 100°C . The output impedance is less than $100 \text{ } \Omega$ and nominal gain is $-0,06 \text{ dB}$. The maximum output current of the 2633 is $1,4 \text{ mA}$ peak. For full specifications, see section 1.2.

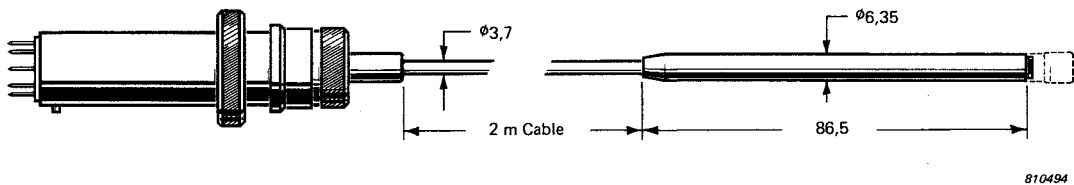

Fig.8.1. Principal dimensions (in mm) of quarter-inch Microphone Preamplifier Type 2633

8.1.3. Half-inch Preamplifier Type 2619

Dimensions of the preamplifier head of the 2619 are shown in Fig.8.2. Details of the circuit are given in the Service Instructions for the 2619.

The 2619 can be delivered as Type 2619 S in a mahogany case containing a one-inch Adaptor DB 0375, an Input Adaptor JJ 2615 and a half-inch diameter Flexible Extension Rod UA 0196. Alternatively, it can be delivered in a plastic case without accessories as Type 2619 T.

The 2619 is designed for use with either 120 V DC or 28 V supply, with or without the heater (see section 8.6). As delivered, it is connected for 120 V supply and the heater is connected. To adapt to 28 V supply, the only alteration required is to connect pins 5 and 6, 28 V then being supplied via either pin. If 28 V polarization is required, this can be provided via pin 6 of the standard B & K Measuring Amplifier, PREAMP. INPUT socket, connecting pin 6 to pin 2 of the connecting socket. If the heater is not required, the connection to pin 7 can be cut inside the 2619 plug.

The input and output characteristics of the 2619 are different according to whether 120 V or 28 V supply is used (see Table 8.2). For full specifications, see section 1.2.

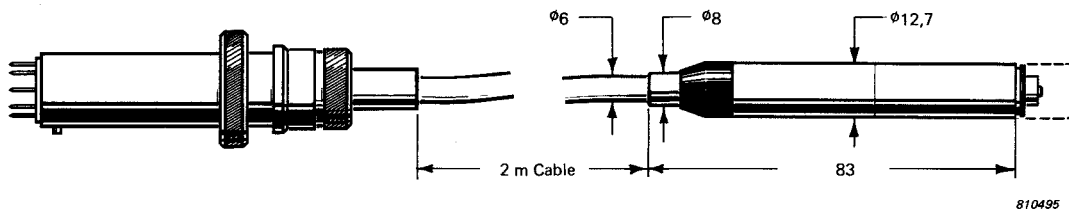

Fig.8.2. Principal dimensions (in mm) of half-inch Microphone Preamplifier Type 2619

	PREAMPLIFIER TYPE 2619	
	120 V supply	28 V supply
Input resistance 20° C	> 10 G Ω	> 7 G Ω
Output resistance	< 25 Ω	< 70 Ω
Input Capacitance, C _i	< 0,8 pF	< 1 pF
Nominal Attenuation (-g)	< 0,03 dB	< 0,1 dB
Maximum Output Voltage	45 V peak	5,6 V peak
Maximum Output Current	1,5 mA peak	0,5 mA peak

740771/2

Table 8.2. Input and output characteristics of Half-inch Microphone Preamplifier Type 2619

8.1.4. One-inch Insert Voltage Preamplifier Type 2627

Dimensions of the 2627 are shown in Fig.8.3. The input configuration is in accordance with IEC Recommendation 327. The particular purpose of this preamplifier is for insert voltage calibration of one-inch microphones. Since it also has a low inherent noise level, it finds other applications in low level measurements.

As an insert voltage preamplifier, the 2627 is delivered with the Reciprocity Calibration Apparatus Type 4143. It can also be used together with any B & K Measuring Amplifier or Analyzer having insert voltage calibration facilities. If the Measuring Amplifier has not this facility (as for example Measuring Amplifiers Types 2610 and 2636), the 2627 can be used as a conventional preamplifier, and insert voltage calibration can be made using the Insert Voltage Junction Box ZH 0007 and an external oscillator inserted between the preamplifier and the measuring instrument.

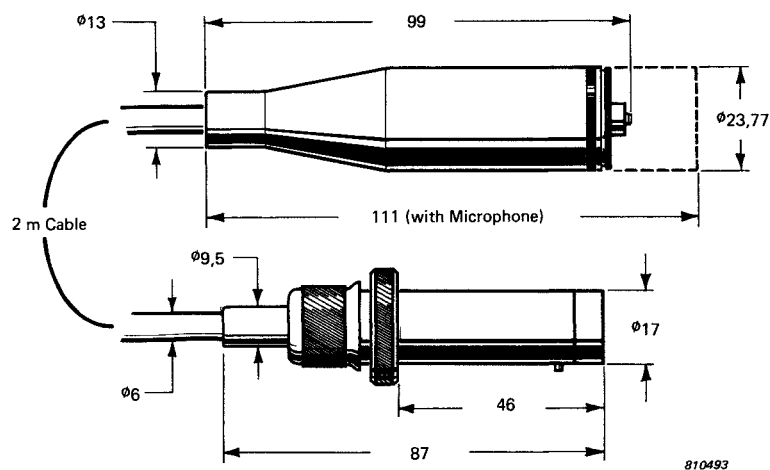

810493

Fig.8.3. Principal dimensions (in mm) of one-inch Insert Voltage Microphone Preamplifier Type 2627

A heating element (180 Ω resistor) is built into the preamplifier. This element raises the temperature slightly above the ambient and reduces condensation of water vapour when the preamplifier is used in a humid environment. The element can be disconnected by a small switch on the printed circuit board, see Fig.8.4. This enables calibration to be made without any temperature influence from the preamplifier.

The shield around the input contact can be connected to ground or to the output of the preamplifier by means of another switch, also shown in Fig.8.4. This allows the use of

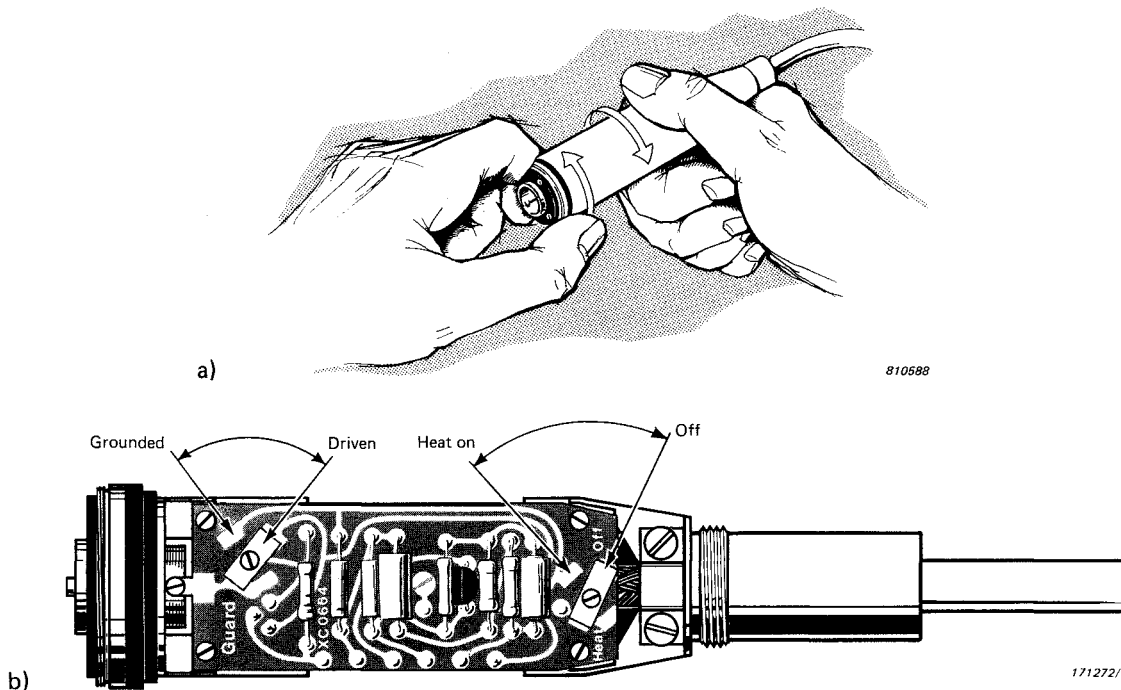

Fig.8.4. a) Removal of Type 2627 case
b) Heater and shield switches

either a driven or a grounded shield. The driven shield will minimize the stray capacitance, and hence reduce the input capacitance of the preamplifier. If the driven shield arrangement is used, the open circuit voltage produced from a microphone by a known sound pressure level differs by less than 0,02 dB from the open circuit voltage which would be obtained if the shield were grounded (ANSI S1.10-1966). The choice of configuration is necessary to be in agreement with different methods used in standards laboratories.

When the preamplifier is dispatched from the factory, the switches are set with the heating element disconnected, and the shield around the input contact in the driven position.

Access to the switches is gained by unscrewing the housing of the preamplifier, see Fig.8.4. The switches are then operated by loosening the small screw with the screwdriver provided, and resetting the link to the position required, see Fig.8.4. The screw is then retightened, taking care not to move the link from its desired position.

Note: The supplies to the preamplifier should be disconnected before the housing is removed and before a transducer is connected to the preamplifier.

The construction of the preamplifier is such that stray capacitances and leakage resistance are kept to a minimum. A double screening ensures a very low crosstalk between insert voltage line and preamplifier. The input contact is spring loaded and gold plated to ensure the best possible electrical connection and low contact noise level. Circuit details are given in the Service Instructions for 2627.

The polarization voltage for a condenser microphone cartridge is supplied through a long time constant charging circuit. After switching on, or after changing cartridges, several seconds should be allowed for the cartridge to charge up.

Input impedance of the 2627 is $> 10 \text{ G}\Omega$ and output impedance $< 50 \Omega$. Input capacitance (C_i in equation 4.1, section 4.3.3) is $< 0,5 \text{ pF}$ with driven shield and $< 5 \text{ pF}$ with

grounded shield. Nominal gain, g , is $-0,08$ dB. Maximum output voltage is 45 V peak and maximum output current 1,4 mA peak. For full specifications, see section 1.2.

8.2. FREQUENCY RESPONSE

The high frequency response of a preamplifier is determined primarily by the output impedance of the preamplifier and the capacitive output load. There is also a secondary effect due to the feedback used in the preamplifier design to reduce input capacitance. This feedback causes phase changes at the output due to the capacitive load which are fed back to the input and result in increased attenuation, especially for low transducer capacitances.

Frequency responses of the preamplifiers without additional extension cables are given in Figs.9 to 11 of section 1.2. To these responses must be added the effect of additional capacitive loads from any extension cable used. These effects are shown in Figs.12 to 14 of section 1.2.

8.3. NOISE

Inherent noise of the preamplifiers is also mainly a function of input capacitive load. Third-octave noise spectra are given for the recommended input loads in Figs.8.5 to 8.8.

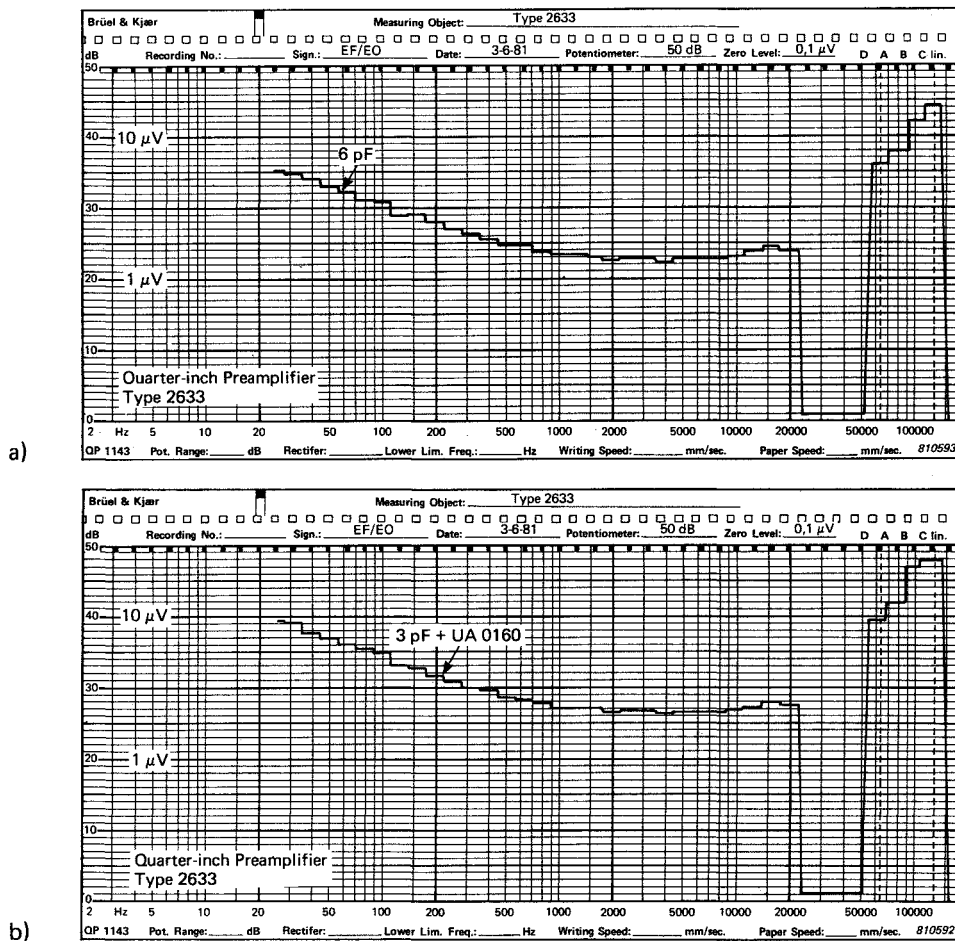

Fig.8.5. Inherent noise of Preamplifier Type 2633 (third-octave analysis) with input capacitance equivalent to:
a) quarter-inch microphone
b) eighth-inch microphone

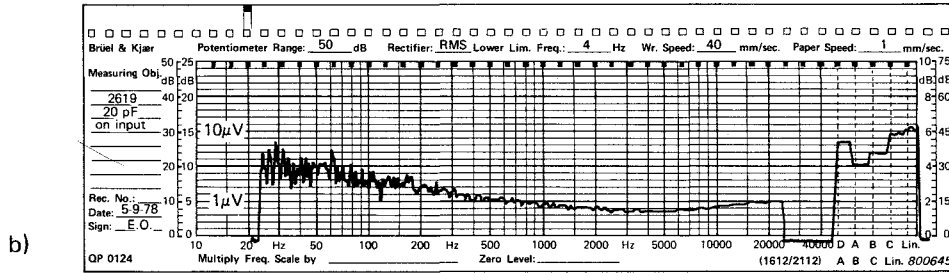
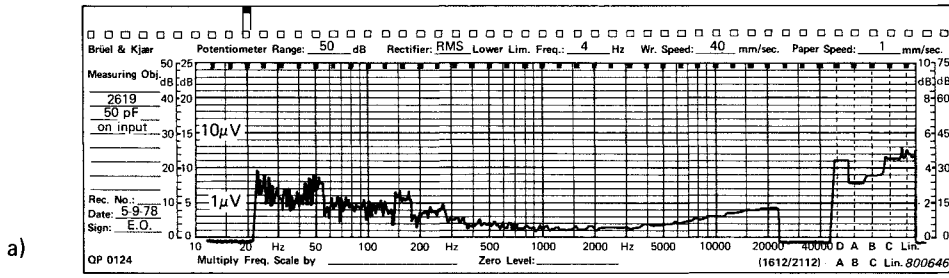

Fig.8.6. *Inherent noise of Preamplifier Type 2619 (third-octave analysis) with input capacitance equivalent to:*
a) one-inch microphone
b) half-inch microphone

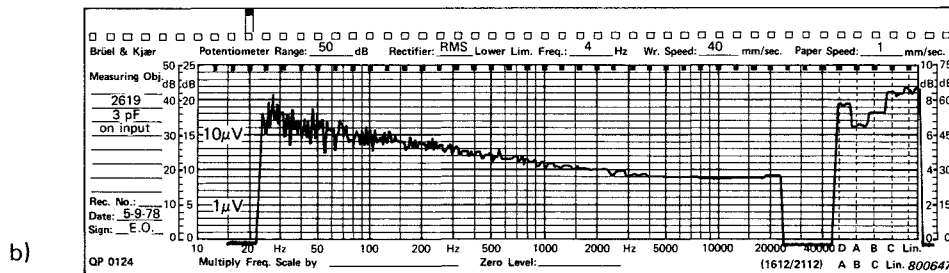
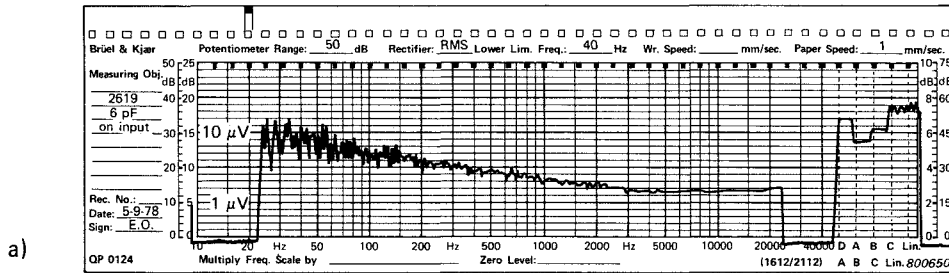

Fig.8.7. *Inherent noise of Preamplifier Type 2619 (third-octave analysis) with input capacitance equivalent to:*
a) quarter-inch microphone
b) eighth-inch microphone

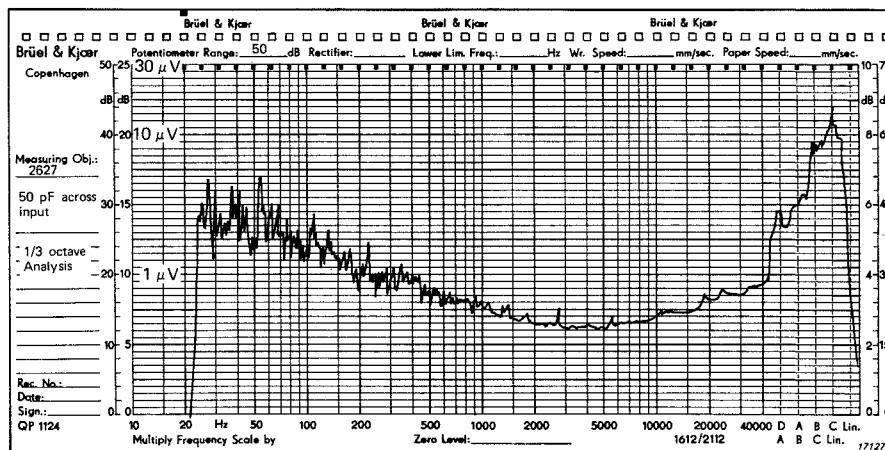

Fig.8.8. *Inherent noise of Preamplifier Type 2627 (third-octave analysis) with input capacitance equivalent to one-inch microphone*

8.4. DISTORTION

The upper limit on the dynamic range of the preamplifier is imposed by maximum available output current or maximum output voltage. Once this is exceeded, output signal distortion will increase. The 4% distortion limit as a function of output capacitive load is given in Figs.15 to 17 of section 1.2.

8.5. PHASE RESPONSE

The phase response of the preamplifiers is shown in Figs.8.9 to 8.11 for input capacitances equivalent to the capacitances of the microphones. In general, the overall phase response of the microphone and preamplifier combination is dominated by the phase response of the microphone (see section 6.5).

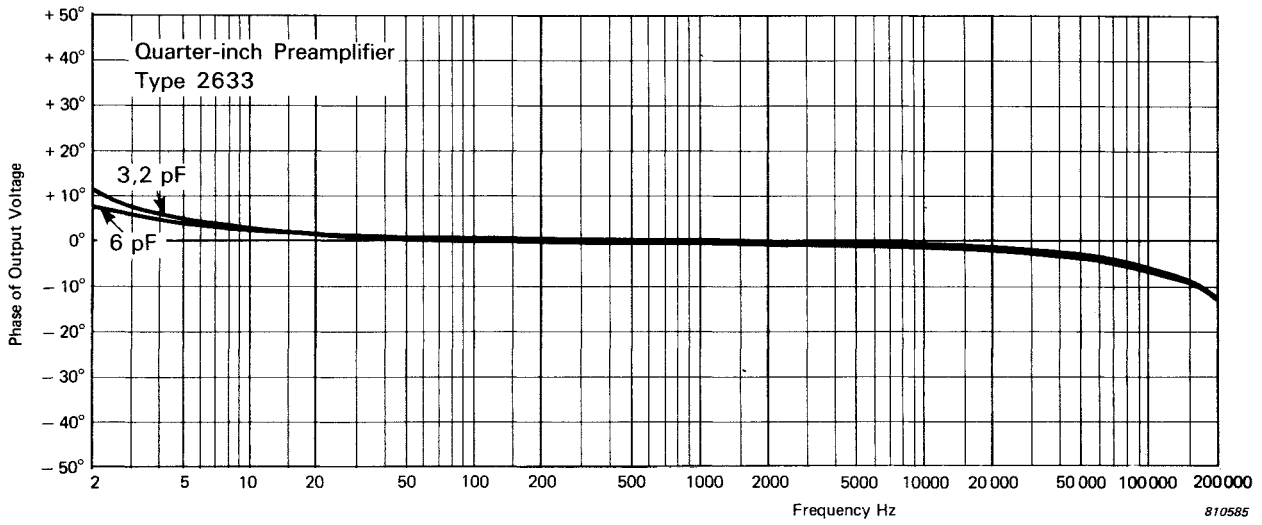

Fig. 8.9. Phase response of Preamplifier Type 2633 with input capacitance equivalent to:
a) quarter-inch microphone
b) eighth-inch microphone

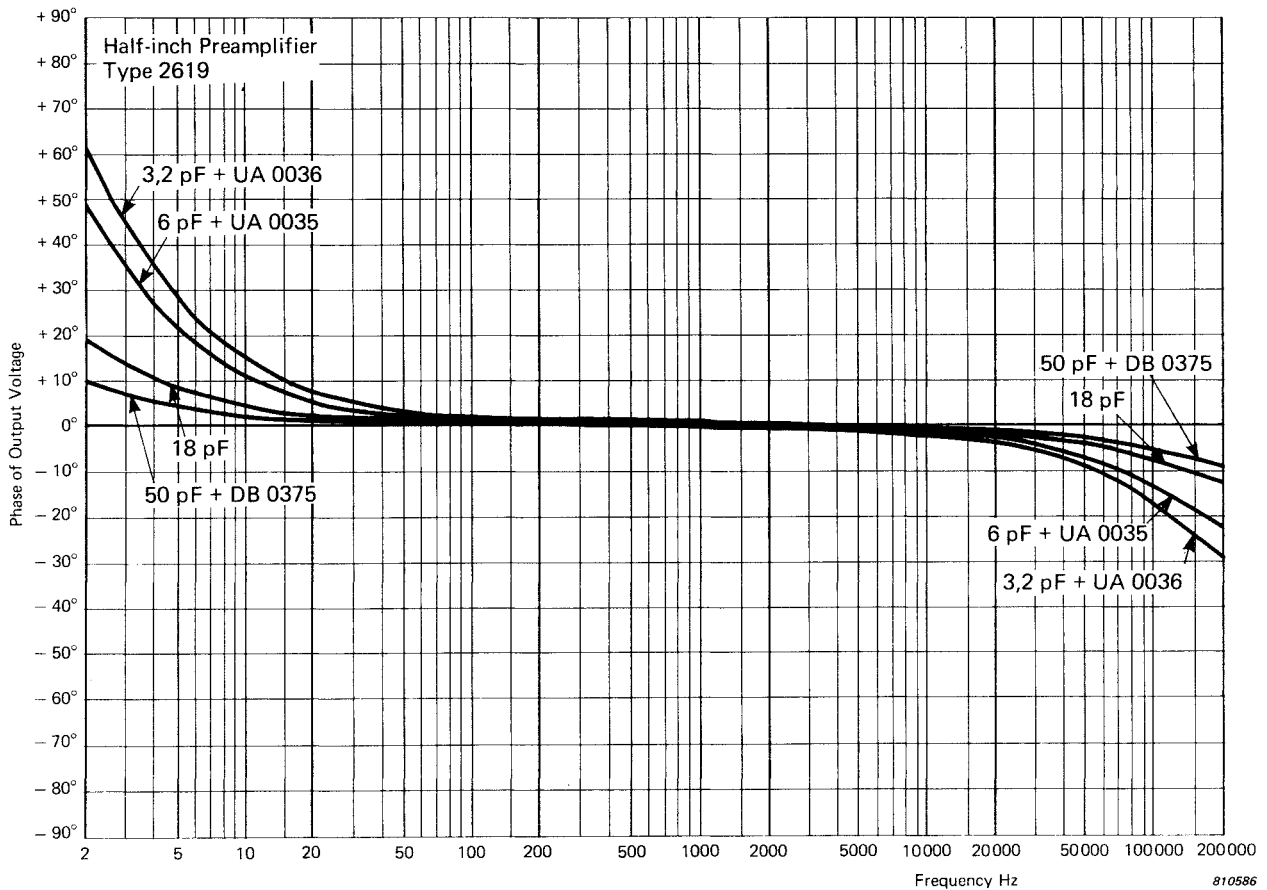

Fig. 8.10. Phase response of Preamplifier Type 2619 with input capacitance equivalent to the different microphones

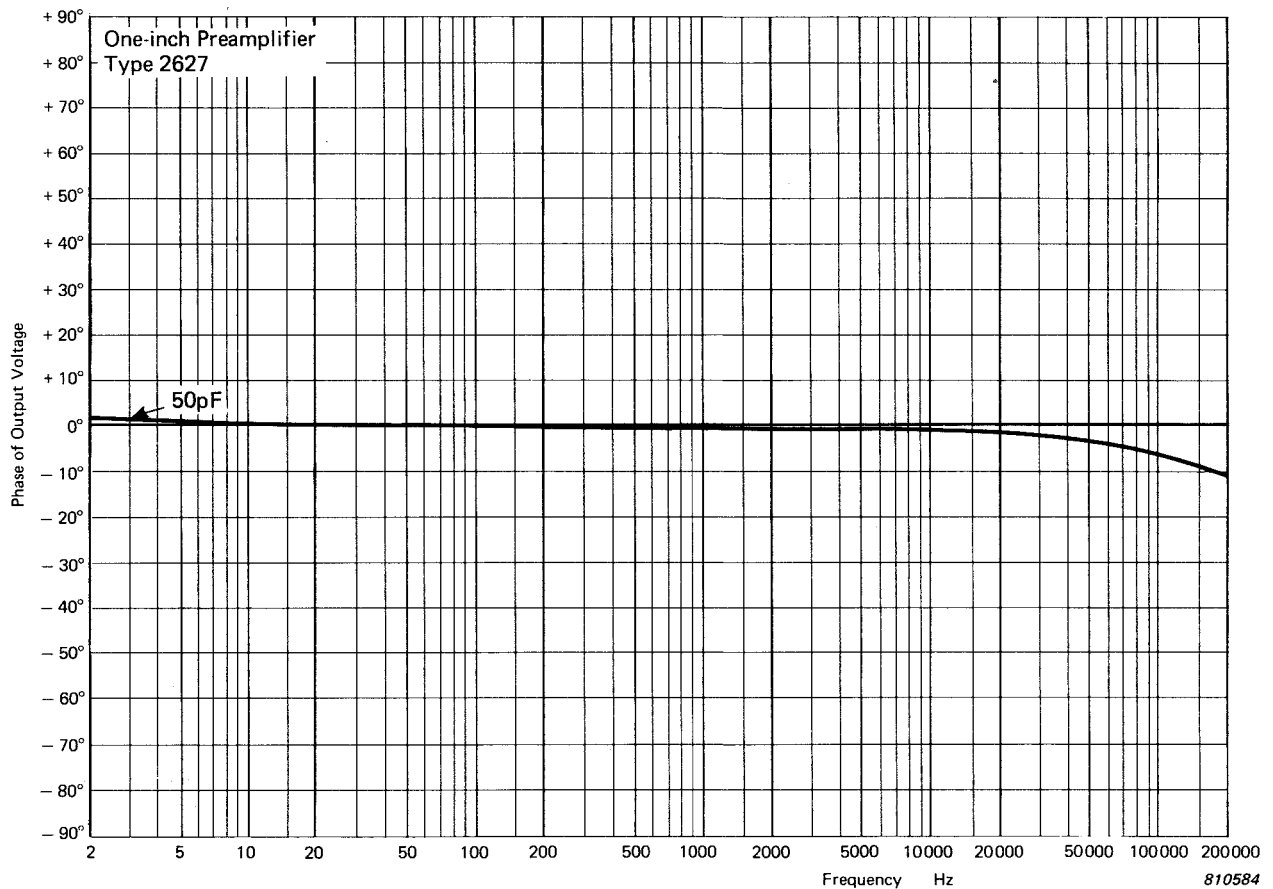

Fig.8.11. Phase response of Preamplifier Type 2627 with input capacitance equivalent to one-inch microphone

8.6. EFFECT OF HUMIDITY

Humid atmospheres have little influence on the preamplifier, and microphone noise problems only arise in the presence of condensation. To discourage condensation, heating elements are built into the 2619 and 2627 preamplifiers (see sections 8.1.3 and 8.1.4). The 2633, however, has no heater but the power dissipated is approx. 250 mW and the preamplifier temperature is approx. 30°C in an environment at room temperature.

8.7. EFFECT OF TEMPERATURE

The preamplifiers operate within the stated specifications (section 1.2) over a range of ambient temperatures from -20°C to + 60°C (-4°F to 140°F). Type 2633 can be used up to 100°C with reduced specifications (see section 1.2). However, by using the available input extensions, the preamplifier may be removed to a cooler environment than the microphone which can continuously operate at temperatures up to 150°C (302°F).

8.8. EFFECT OF SOUND FIELD

The response of the preamplifier itself to an intense sound field is so low that it can for all practical purposes be neglected. This has been confirmed in tests with dummy microphones.

8.9. EFFECT OF VIBRATION

The effect of vibration on the preamplifiers can be seen in Table 8.3 where the vibration-induced voltages and corresponding equivalent sound pressure levels for different microphone and preamplifier combinations are given. The preamplifiers are vibrated in the direction of greatest sensitivity and the highest voltage obtained during a frequency sweep from 10 Hz to 2 kHz was noted. Dummy microphones (and adaptors, where necessary) were fitted to the preamplifiers, and the complete assembly clamped to the vibration table to give well defined conditions.

Preamplifier Type	Dummy Microphone Size	Vibration-Induced Voltage*	Equivalent Sound Pressure Level (dB re 20 μ Pa)
2627	one-inch (50pF)	4 mV	72
2619	DB 0375 + one-inch (50pF)	400 μ V	52
	half-inch (20pF)	50 μ V	34 (50 mV/Pa sensitivity)
			46 (12,5 mV/Pa sensitivity)
	UA 0035 + quarter-inch (6pF)	400 μ V	74 (4 mV/Pa sensitivity)
			82 (1,6 mV/Pa sensitivity)
UA 0036 + eighth-inch (3pF)	1 mV	94	
2633	quarter-inch (6pF)	40 μ V	54 (4 mV/Pa sensitivity)
			62 (1,6 mV/Pa sensitivity)
	UA 0160 + eighth-inch (3pF)	250 μ V	82

* Vibration level of 1 m/s² applied in the direction of greatest sensitivity

810090

Table 8.3. Vibration sensitivity of preamplifiers

8.10. EFFECT OF MAGNETIC FIELDS

The preamplifiers will operate satisfactorily without deviation from specifications in a magnetic field of strength up to at least 100 A/m at 50 Hz. The sensitivity to the preamplifiers to magnetic fields is greatest when the field direction is perpendicular to the preamplifier axis. The field-induced voltages at 50 Hz for an 80 A/m magnetic field applied in the direction of greatest sensitivity are given in Table 8.4 for various preamplifier and dummy microphone combinations.

Preamplifier Type	Dummy Microphone Size	Induced Voltage (μV)	Equivalent Sound Pressure Level (dB re 20 μPa)
2627	one-inch (50pF)	5	14
2619	DB 0375 + one-inch (50pF)	3	10
	half-inch (20pF)	4	12 (50 mV/Pa sensitivity)
			24 (12,5 mV/Pa sensitivity)
	UA 0035 + quarter-inch (6pF)	5	36 (4 mV/Pa sensitivity)
			44 (1,6 mV/Pa sensitivity)
UA 0036 + eighth-inch (3pF)	8	52	
2633	quarter-inch (6pF)	4	34 (4 mV/Pa sensitivity)
			42 (1,6 mV/Pa sensitivity)
	UA 0160 + eighth-inch (3pF)	4	46

810091

Table 8.4. Sensitivity to magnetic field of 80 A/m at 50 Hz

9. ACCESSORIES

9.1. INTRODUCTION

A survey of the accessories available for B & K microphones is given in section 1.1. Many of the accessories referred to are discussed in adequate detail in section 1.1, and there is no useful purpose to be served by repetition in this chapter. However, a summary list here will serve to provide proper reference to where the fullest information about an accessory is to be found.

9.1.1. Accessories Providing Immunity from the Environment

UA 0570	Permanent Outdoor Windscreen	Section 9.2
UA 0207	Foam windscreen, one-inch	Section 9.2
UA 0237	Foam windscreen, half-inch	Section 9.2
UA 0459	Foam Windscreen, half-inch	Section 1.1
UA 0393	Rain Cover	Section 9.3
UA 0387	Nose Cone, one-inch	Section 9.4
UA 0386	Nose Cone, half-inch	Section 9.4
UA 0385	Nose Cone, quarter-inch	Section 9.4
UA 0355	Nose Cone, eighth-inch	Section 9.4
UA 0308	Dehumidifier, half-inch	Sections 1.1 and 9.7
UA 0436	Turbulence Screen	Section 9.5
4921	Outdoor Microphone Unit	Section 1.1 and Manual 4921

9.1.2. Accessories for Achieving Special Characteristics

UA 0055	Random Incidence Corrector	Section 9.6
UA 0240	Microphone Sealing Kit, one-inch	Sections 1.1 and 5.3
4152	Artificial Ear IEC R 126, ANSI Z24.9-1949	4152 Manual
4153	Artificial Ear IEC R 318	4153 Manual
DB 0138	Coupler IEC R 126 (2 cm ³)	4152 Manual
DB 0161	Coupler ANSI Type 1 (6 cm ³)	4152 Manual
DB 0909	Coupler NBS (6 cm ³)	4152 Manual

9.1.3. Adaptors and Cables

DB 0111	Coupler adaptor ring, one-inch	4143 Manual
DB 0225	Coupler adaptor, half-inch to one-inch	4143 Manual
DB 0264	Coupler adaptor, quarter-inch to half-inch	4143 Manual
DB 0900	Coupler adaptor, eighth-inch to half-inch	4143 Manual
UA 0271	Special one-inch to half-inch adaptor for 2631 to 4147	2631 Manual
UA 0030	One-inch to half-inch adaptor	Section 1.1

DB 0375	Half-inch to one-inch adaptor	Section 1.1
DB 0962	Half-inch to one-inch adaptor	Section 1.1
UA 0035	Half-inch to quarter-inch adaptor	Section 1.1
UA 0036	Half-inch to eighth-inch adaptor	Section 1.1
UA 0160	Quarter-inch to eighth-inch adaptor	Section 1.1
UA 0196	Flexible rod, half-inch to half-inch	Section 1.1
UA 0122	Flexible connector	Section 1.1
UA 0123	Flexible connector	Section 1.1
UA 0587	Portable Floor Stand	Section 1.1
UA 0588	Tripod Adaptor	Section 1.1
AO 0063	Extension Cable — preamp. input — 3 m	Section 1.1
AO 0027	Microphone Extension Cable, 3 m	Section 1.1
AO 0028	Microphone Extension Cable, 10 m	Section 1.1
AO 0029	Microphone Extension Cable, 30 m	Section 1.1
AR 0001	Tape Microphone Cable	Section 1.1

9.1.4. Calibration Equipment

UA 0023	Electrostatic Actuator, one-inch	4143 Manual
UA 0033	Electrostatic Actuator, half-inch	4143 Manual
4143	Reciprocity Calibration Apparatus	4143 Manual
4220	Pistonphone	4220 Manual
4221	High Pressure Microphone Calibrator	4221 Manual
4230	Sound Level Calibrator	4230 Manual

9.2. WINDSCREENS

9.2.1. Permanent Outdoor Windscreen UA 0570

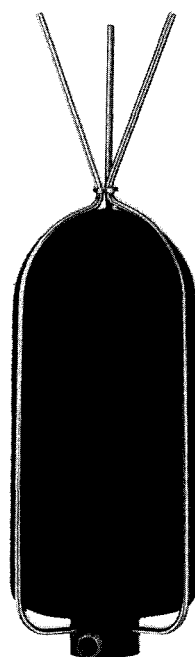

Fig.9.1. Windscreen UA 0570

The Windscreen UA 0570, shown in Fig.9.1., is designed for use in unattended outdoor monitoring applications using a half-inch microphone. The Windscreen is made from a specially prepared porous polyurethane foam which is resistant to humid and corrosive atmospheres and is supported by three stainless steel rods which protrude as spikes preventing interference from birds. The design of the foam screen and stainless steel frame provides excellent long term mechanical stability.

The recommended system for use with the Windscreen consists of a half-inch condenser microphone, Rain Cover UA 0393, Dehumidifier UA 0308 and microphone preamplifier which are inserted into the hard plastic (P.O.M.) conical ring at the base of the Windscreen and secured with a nylon screw, as shown in Fig.9.2.

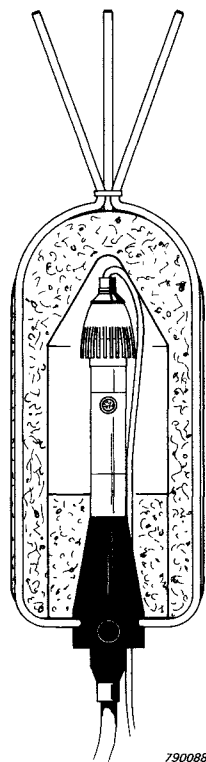

Fig.9.2. Half-inch microphone and preamplifier fitted with Rain Cover UA 0393 and Dehumidifier UA 0308 mounted inside Windscreen UA 0570

The Windscreen gives an effective reduction of wind noise of the order of 15 dB for wind speeds up to 120 km/h. The attenuation of a wet screen differs from that of a dry screen by only $\pm 0,5$ dB up to 9 kHz as shown in Fig.9.3. Wind induced noise levels for half-inch Condenser Microphones Types 4133 and 4149 fitted with Rain Cover UA 0393 and Windscreen UA 0570 are shown in Figs.9.4 to 9.6. Free-field correction curves are given in Fig.9.7 for half-inch Condenser Microphones Types 4133 and 4149, fitted with Rain Cover UA 0393 and Windscreen UA 0570.

Windscreen UA 0570 is also delivered as part of the Outdoor Microphone Unit Type 4921 which is designed for permanent outdoor noise monitoring systems. The unit consists of the quartz coated half-inch Condenser Microphone Type 4149, Rain Cover UA 0393, Windscreen UA 0570, and a Preamplifier mounted on a weather proof case housing an amplifier, calibration oscillator, dehumidifier and a battery pack. For further details, see the 4921 Instruction Manual.

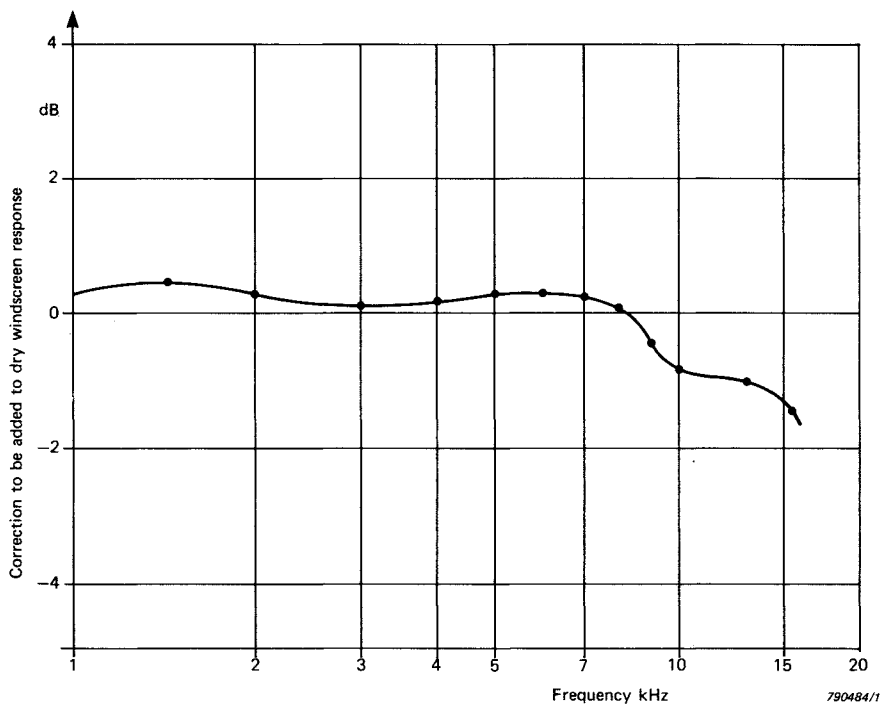

Fig.9.3. Effect of wet screen on the attenuation of Windscreen UA 0570

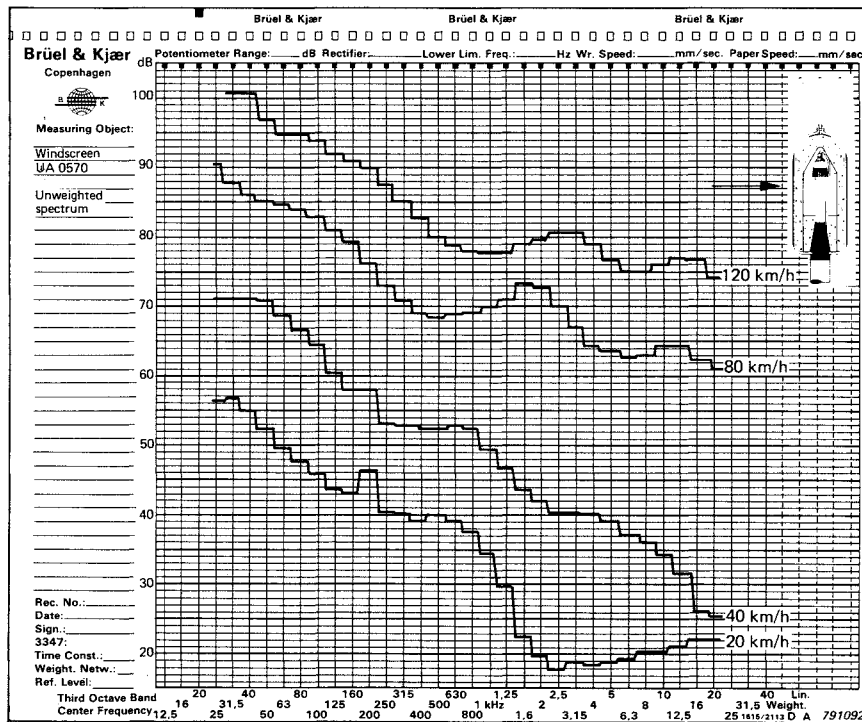

Fig. 9.4. 90° incidence wind induced noise levels for half-inch microphone Type 4133/49 fitted with Rain Cover UA 0393 and Dehumidifier UA 0308 mounted inside Windscreen UA 0570

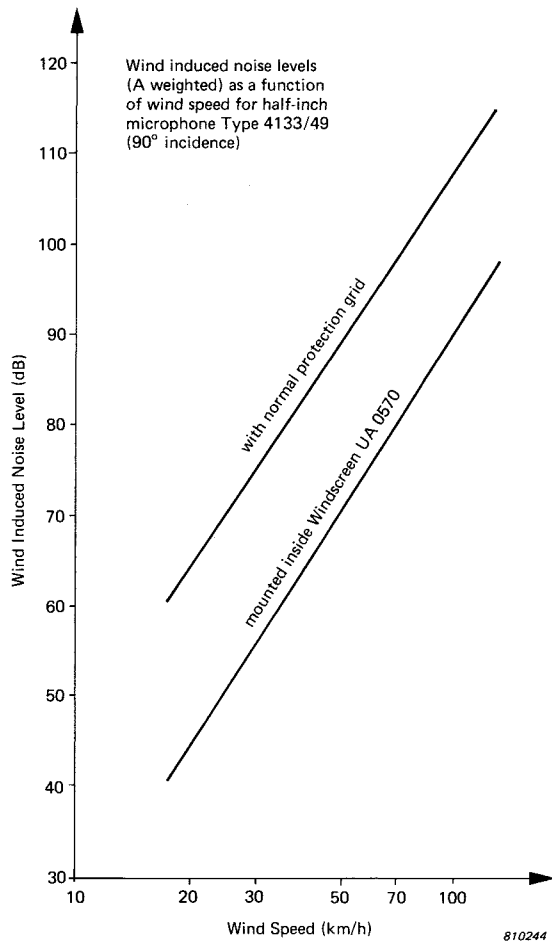

Fig. 9.5. A-weighted wind induced noise level as a function of wind speed for half-inch microphone Type 4133/49 fitted with Rain Cover UA 0393 and Dehumidifier UA 0308 mounted inside Windscreen UA 0570

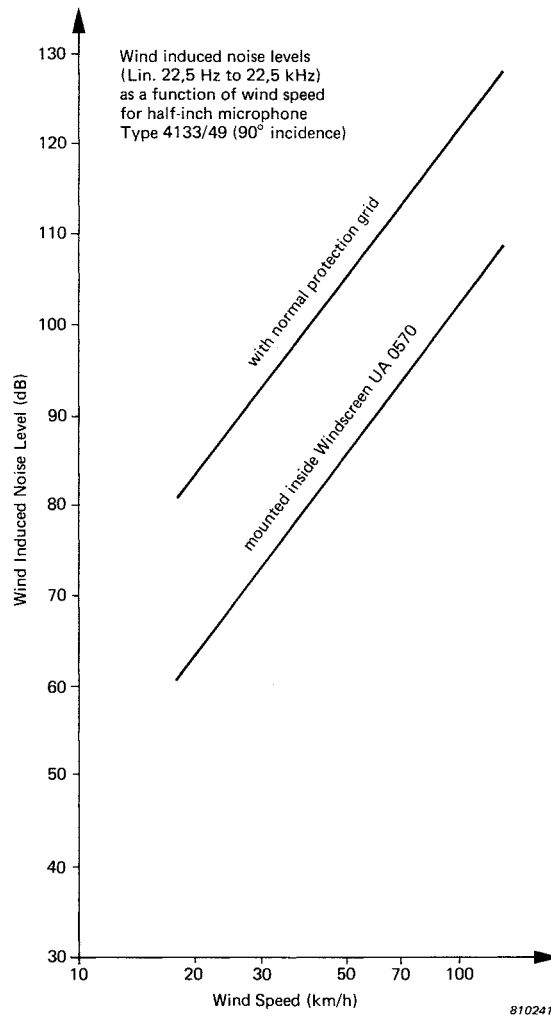

Fig. 9.6. Linear wind induced noise level as a function of wind speed for half-inch microphone Type 4133/49 fitted with Rain Cover UA 0393 and Dehumidifier UA 0308 mounted inside Windscreen UA 0570

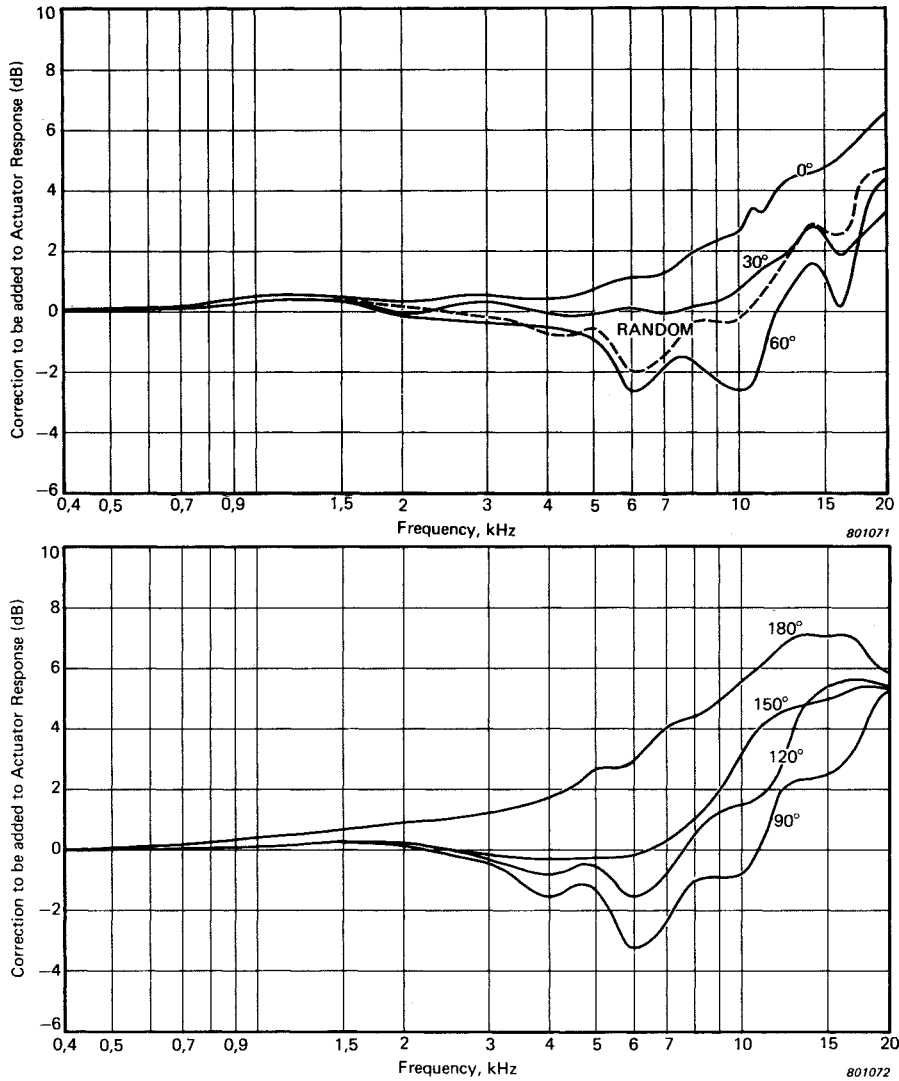

Fig. 9.7. Free-field correction curves for half-inch microphone Type 4133/49 fitted with Rain Cover UA 0393 and Dehumidifier UA 0308 mounted inside Windscreen UA 0570

9.2.2. Foam Windscreens

The Windscreens UA 0207 and UA 0237 are available for use with one-inch and half-inch microphones respectively. The Windscreens are identical in size and material, and differ only in the diameter of the cylindrical hole provided for insertion of the microphone and preamplifier.

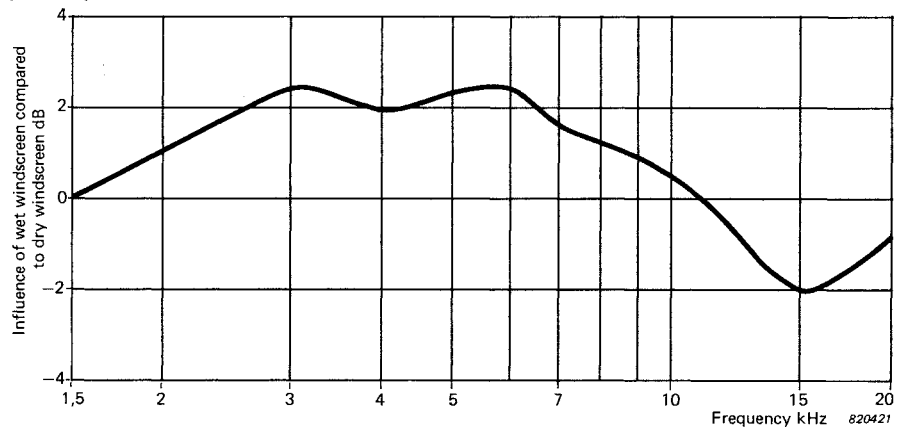
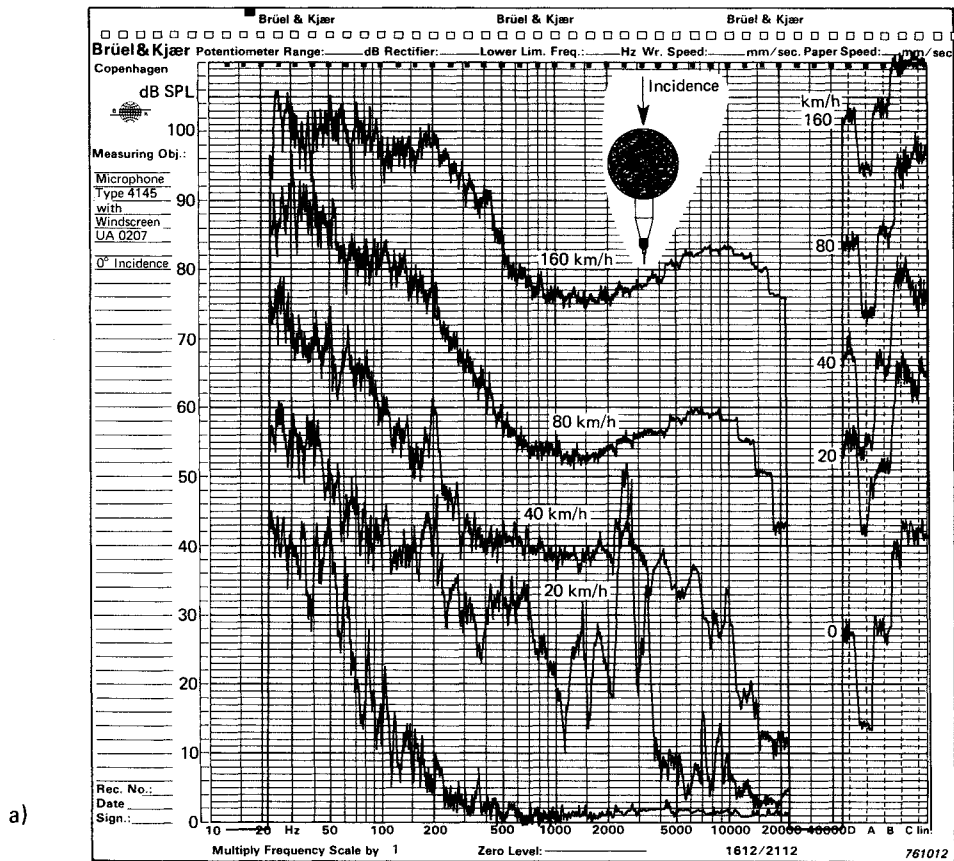
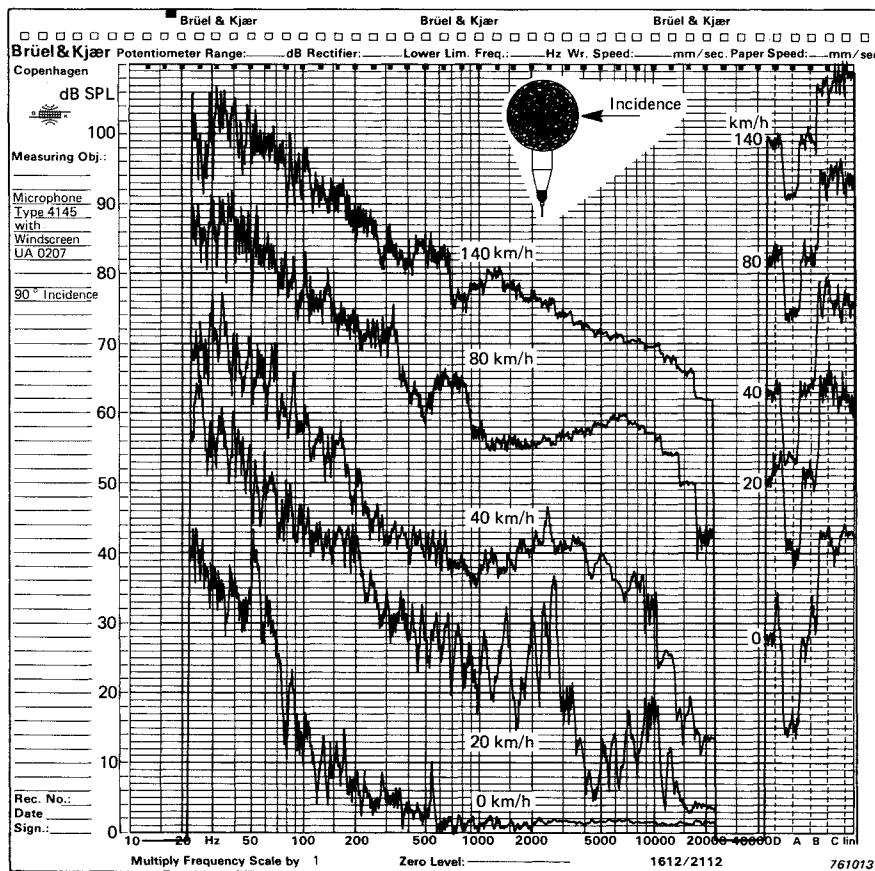

Fig.9.8. Effect of UA 0237 wet screen 0° incidence free-field response of half-inch microphone Type 4133



a)



b)

Fig.9.9. Wind induced noise levels for one-inch microphones fitted with Windscreen UA 0207
a) 0° incidence b) 90° incidence

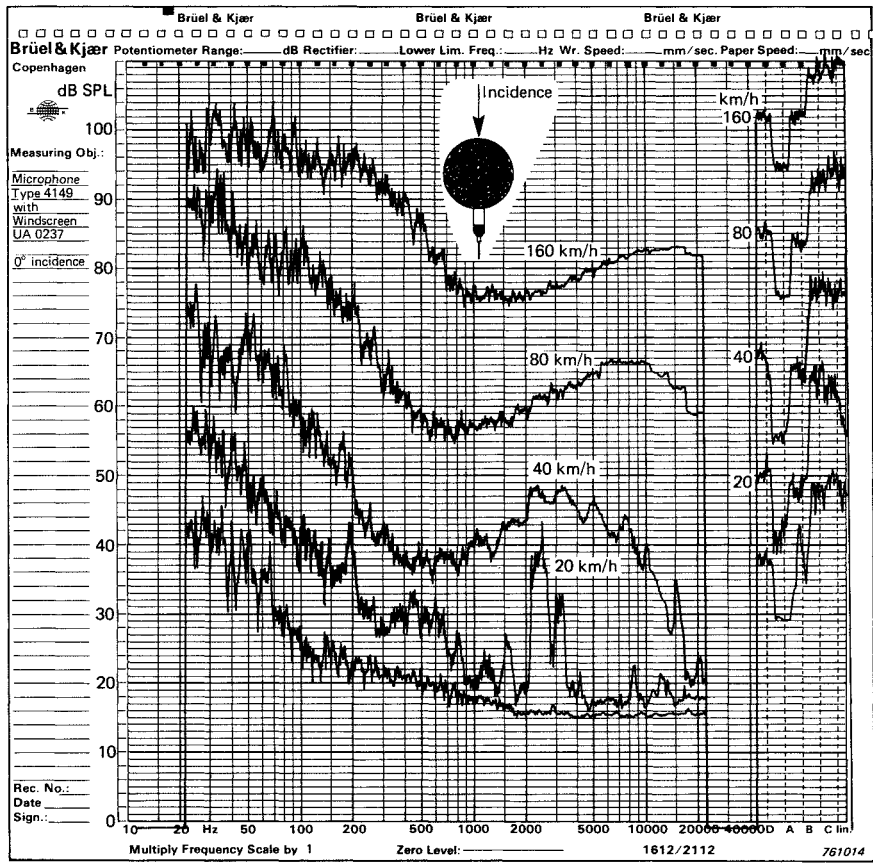

a)

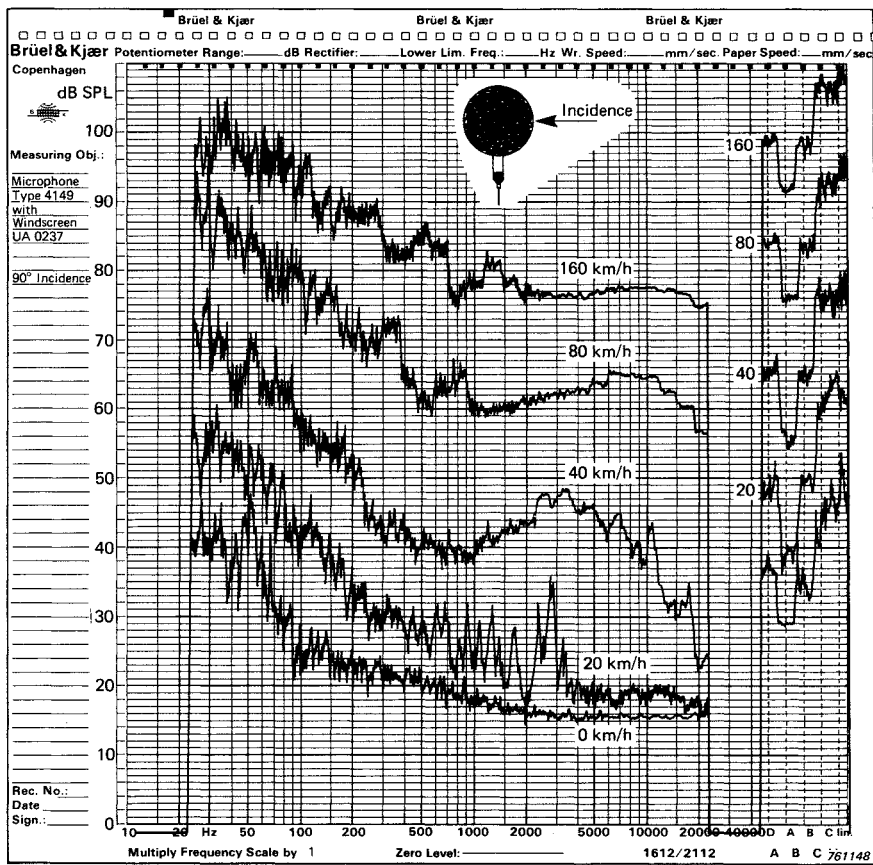

b)

Fig.9.10. Wind induced noise levels for half-inch microphones fitted with Windscreen UA 0237
 a) 0° incidence b) 90° incidence

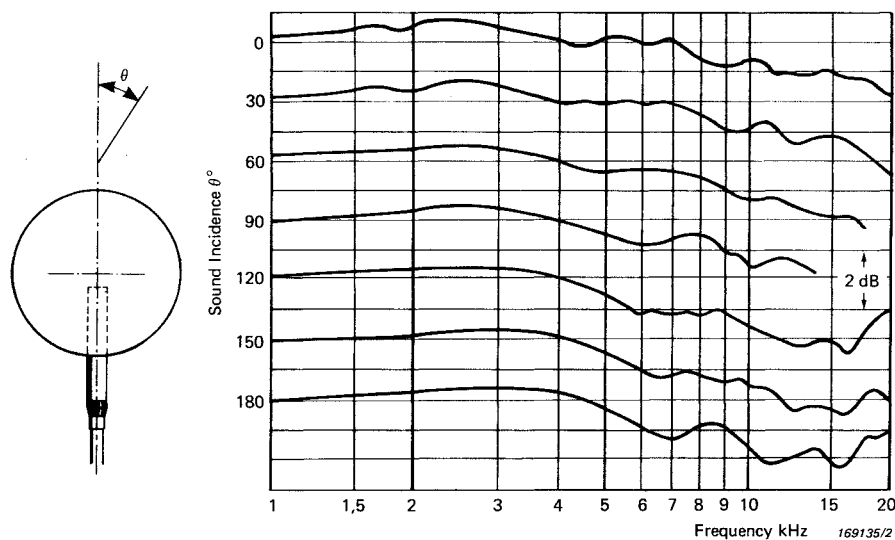

Fig.9.11. Increments to free-field correction curves due to Windscreen UA 0207

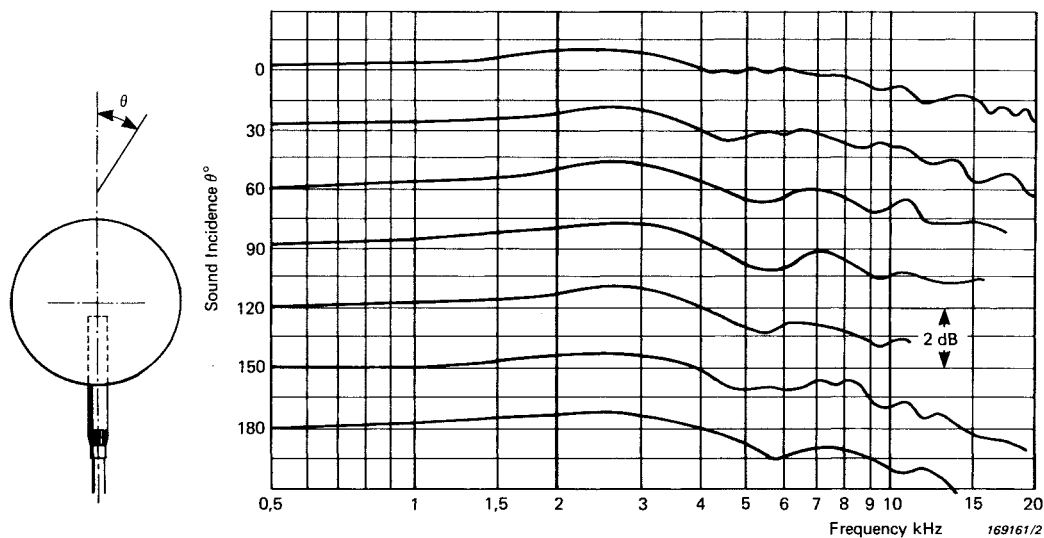

Fig.9.12. Increments to free-field correction curves due to Windscreen UA 0237

The Windscreen material is a specially prepared type of open-pored polyurethane foam. Diameter is 90 mm and in use the Windscreen is simply pushed as far as it will go over the microphone (fitted with its normal protection grid) and preamplifier. Wind-induced noise for one-inch and half-inch microphones fitted with the foam windscreens is shown in Figs.9.9 and 9.10. Free-field response corrections for the Windscreens are given in Figs.9.11 and 9.12. These curves should be added to the normal free-field characteristic of the microphone.

A smaller (65 mm dia.) Windscreen, UA 0459, is also available. This is briefly described in Section 1.1.

9.3. RAIN COVER UA 0393

A Rain Cover is available only for the half-inch microphone size. The Rain Cover UA 0393, shown in Fig.9.13, is designed to be mounted on a half-inch microphone in place of the normal protection grid, and as well as rain protection, it serves as an electrostatic actuator

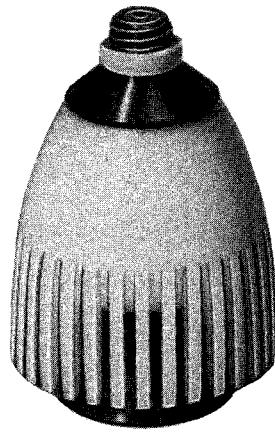

Fig.9.13. Rain Cover UA 0393

calibrator which can be excited for remote calibration. It is important to mount the unit upright, the microphone diaphragm facing straight up. The Rain Cover can be delivered together with a half-inch free-field microphone (4149 is particularly recommended for permanent outdoor use), factory calibrated to give an equivalent sound pressure level of 90 ± 1 dB when 215 V AC is applied to the actuator terminal (80 ± 1 dB for 121 V AC).

Free-field corrections of the half-inch microphones fitted with the Rain Cover are given in Fig.9.14. From these curves, the response of the half-inch microphone can be drawn as shown in Fig.9.15.

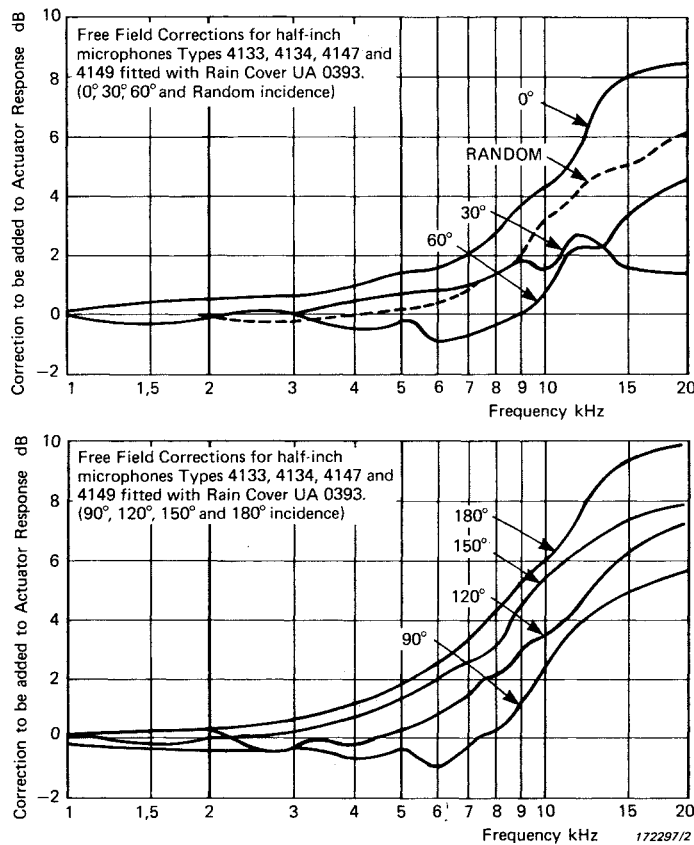

Fig.9.14. Free-field correction curves for half-inch microphones Types 4133 and 4149 fitted with Rain Cover UA 0393

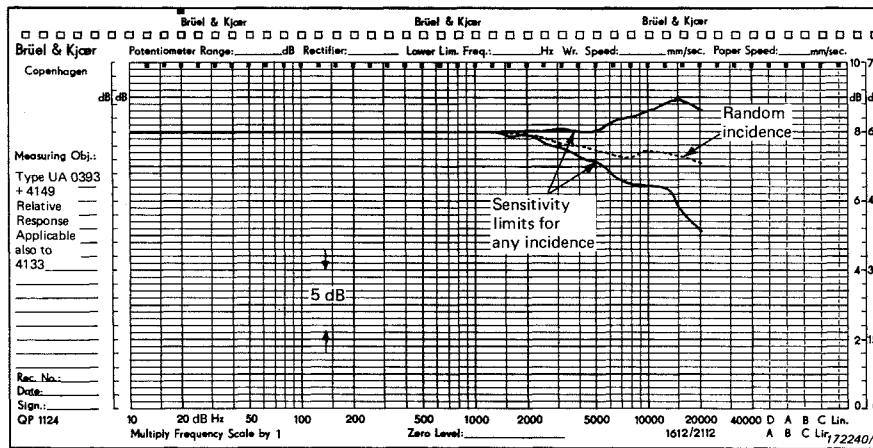

Fig.9.15. Sensitivity limits for any incidence for half-inch microphones Types 4133 and 4149 fitted Rain Cover UA 0393

A particularly recommended outdoor installation, suitable for use in all weathers, is a 4149 microphone fitted with UA 0393 Rain Cover, UA 0308 dehumidifier (section 1.1), and Windscreen UA 0570 (section 9.2.1). This combination also meets the directional requirements of IEC 651 Type 1 for precision sound level measurements. The microphone is best protected in such an outdoor application when the preamplifier heater is permanently on.

Maximum temperature to which the Rain Cover should be subjected is 150°C.

Note that the electrostatic actuator of the Rain Cover is not recommended for frequency response calibration because the presence of the Rain Cover itself influences the linearity of the frequency characteristics at high frequencies.

9.4. NOSE CONES

Nose Cones are available for all sizes of B & K Microphone. The sizes and stock numbers are identified in Fig.9.16.

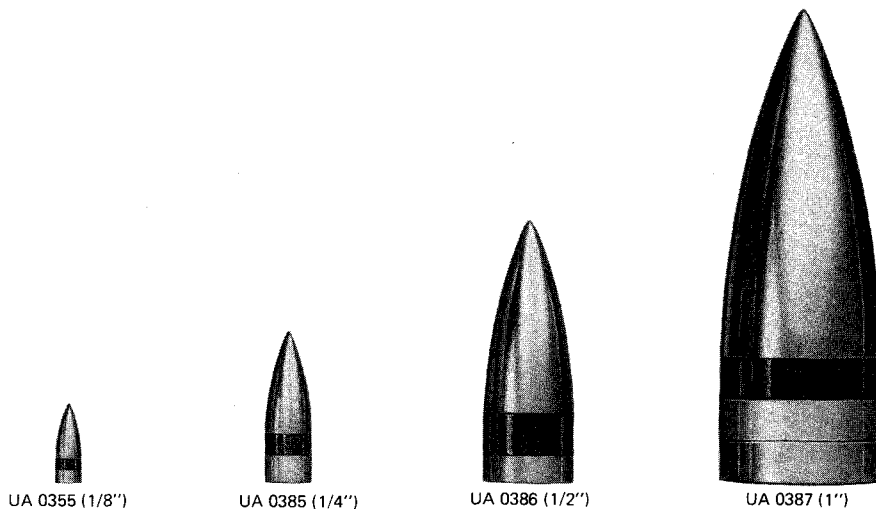

740831

Fig.9.16. Nose Cones UA 0355, UA 0385, UA 0386 and UA 0387

The Nose Cone is designed to substitute the normal protection grid of the microphone and is intended for use in air flows of high speed and well defined direction. Its streamlined shape gives the least possible resistance to air flow, thereby reducing turbulence. A fine wire mesh around the Nose Cone permits sound pressure transmission to the microphone diaphragm while a truncated cone behind the mesh reduces the air volume in front of the diaphragm as shown in Fig.9.17. Typical wind-induced noise levels are shown for the four sizes in Figs.9.18 to 9.21. Free-field corrections for the respective sizes of Nose Cone are given in Figs.9.22 to 9.28, while the effects on microphone frequency response are more easily seen from Figs.9.29 to 9.33.

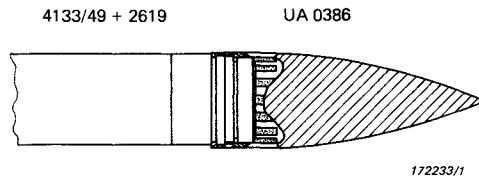

Fig.9.17. Cross section of Nose Cone UA 0386

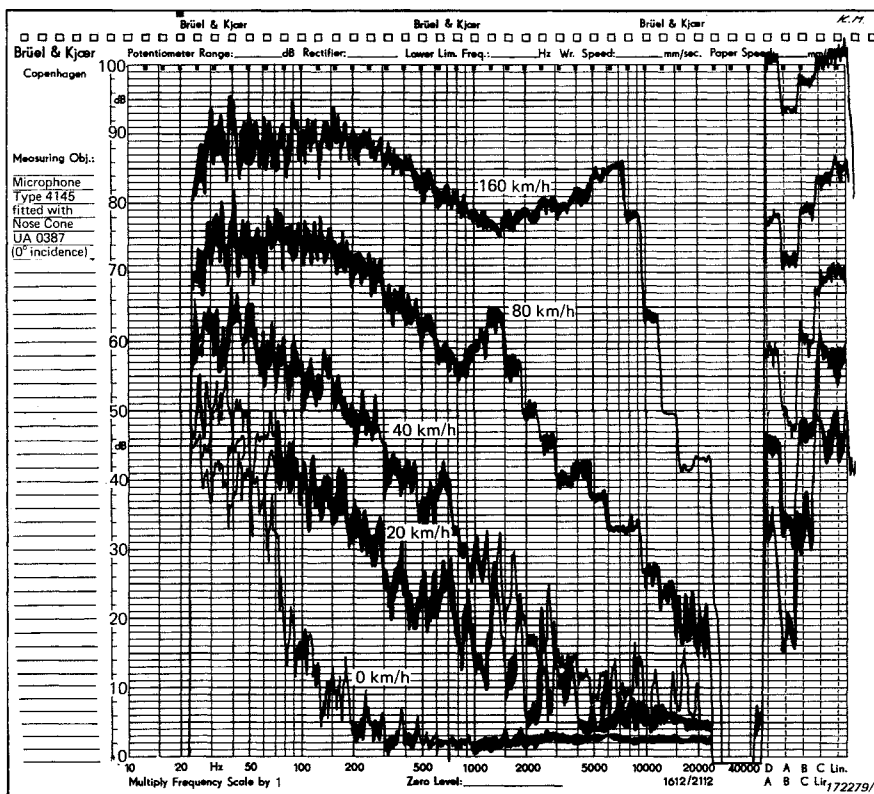

Fig.9.18. Wind induced noise levels for one-inch microphones fitted with Nose Cone UA 0387. 0° incidence

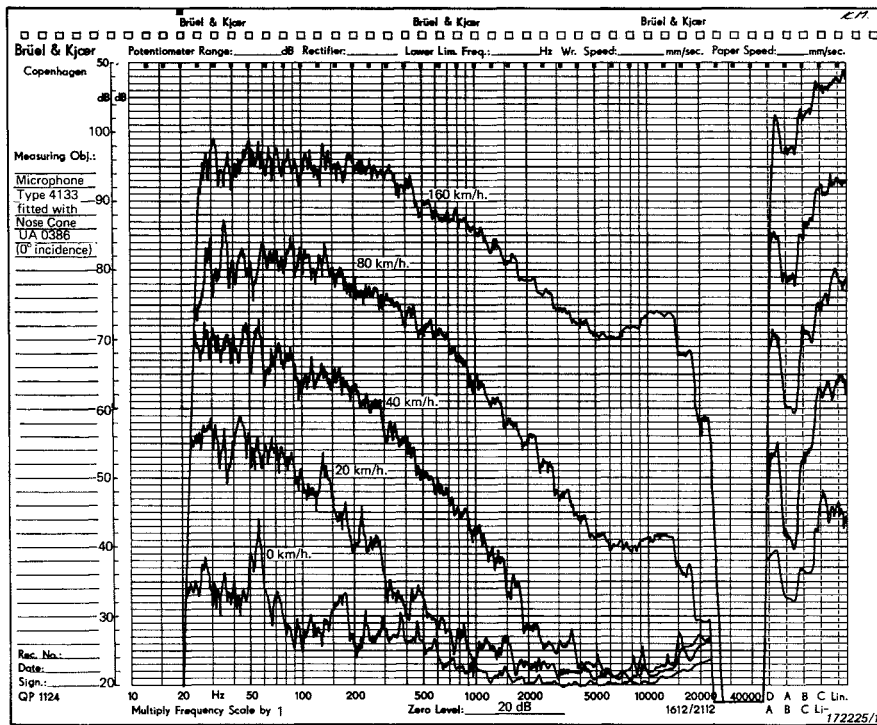

Fig.9.19. Wind induced noise levels for half-inch microphones fitted with Nose Cone UA 0386. 0° incidence

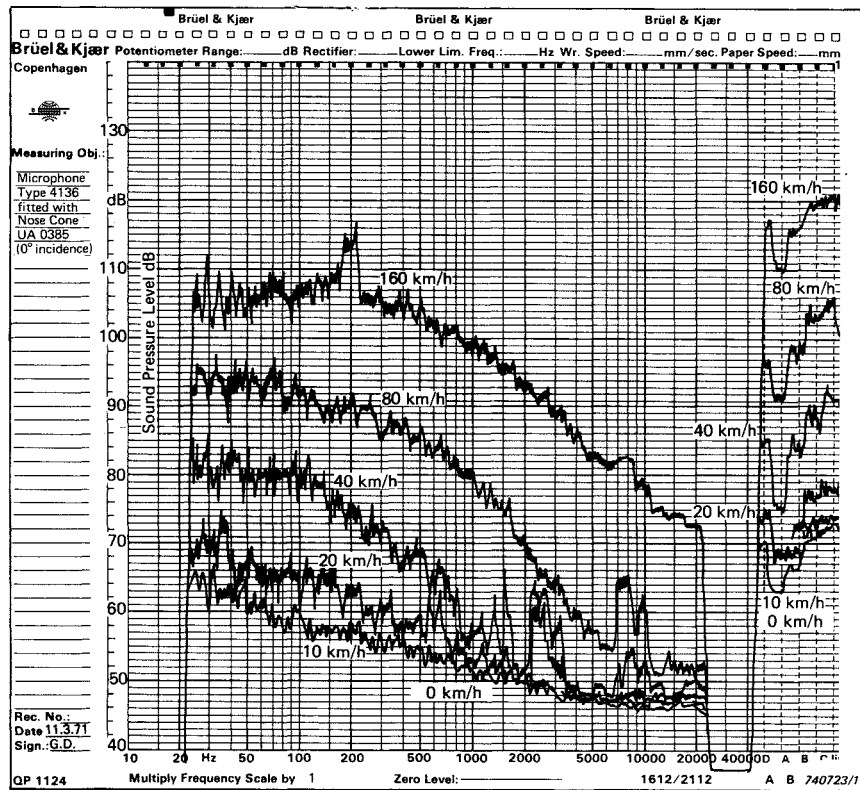

Fig.9.20. Wind induced noise levels for quarter-inch microphones fitted with Nose Cone UA 0385. 0° incidence

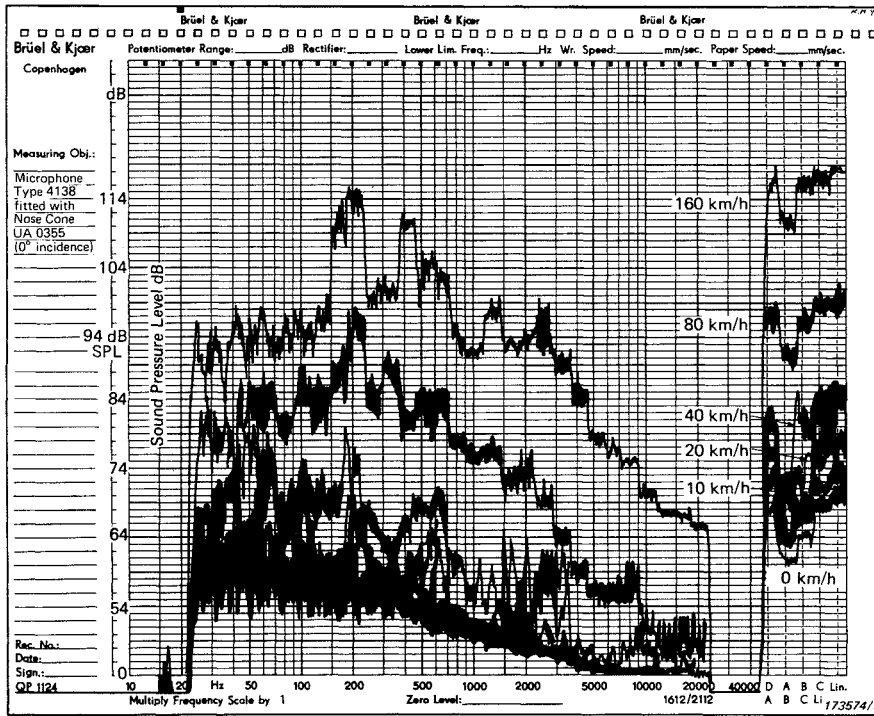

Fig.9.21. Wind induced noise levels for eighth-inch microphone fitted with Nose Cone UA 0355. 0° incidence

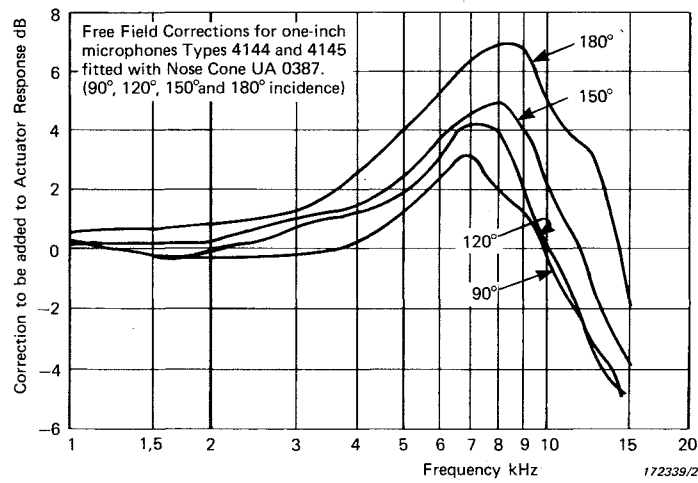
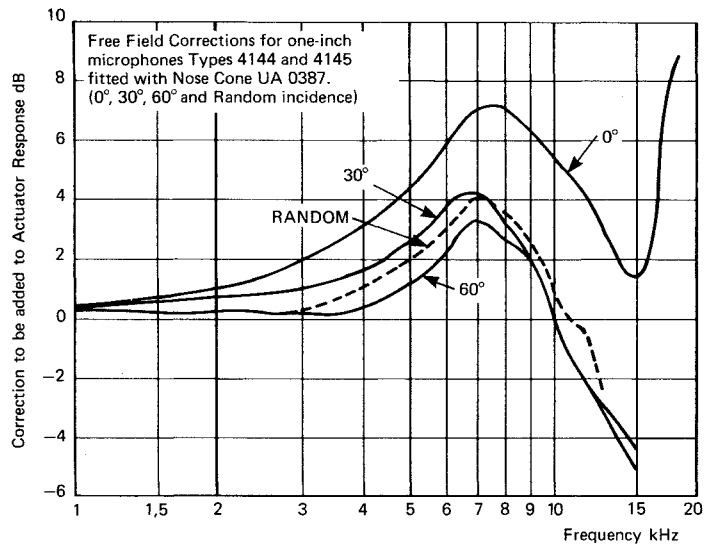

Fig.9.22. Free-field correction curves for one-inch microphones Types 4144 and 4145 fitted with Nose Cone UA 0387

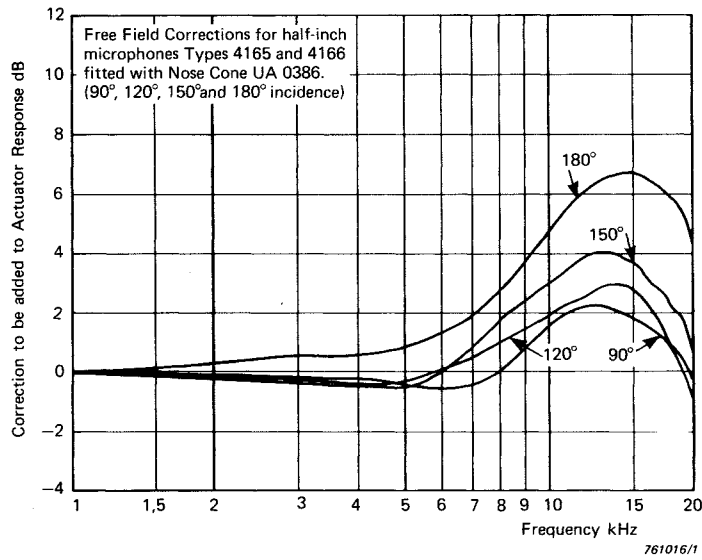
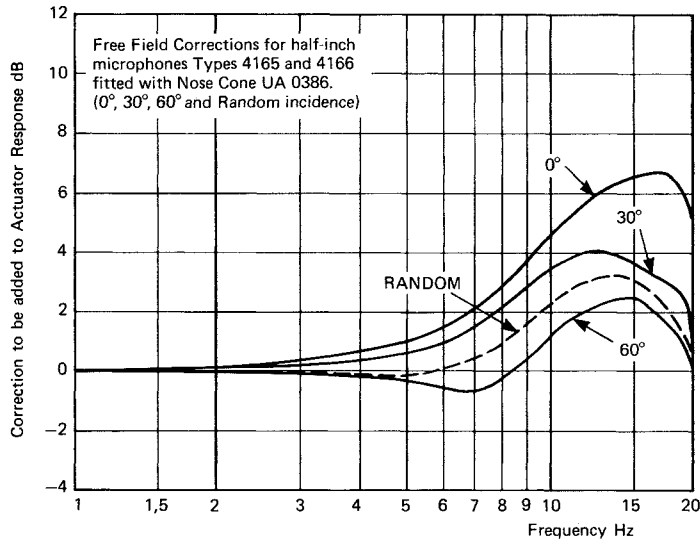

Fig.9.23. Free-field correction curves for half-inch microphones Types 4165 and 4166 fitted with Nose Cone UA 0386

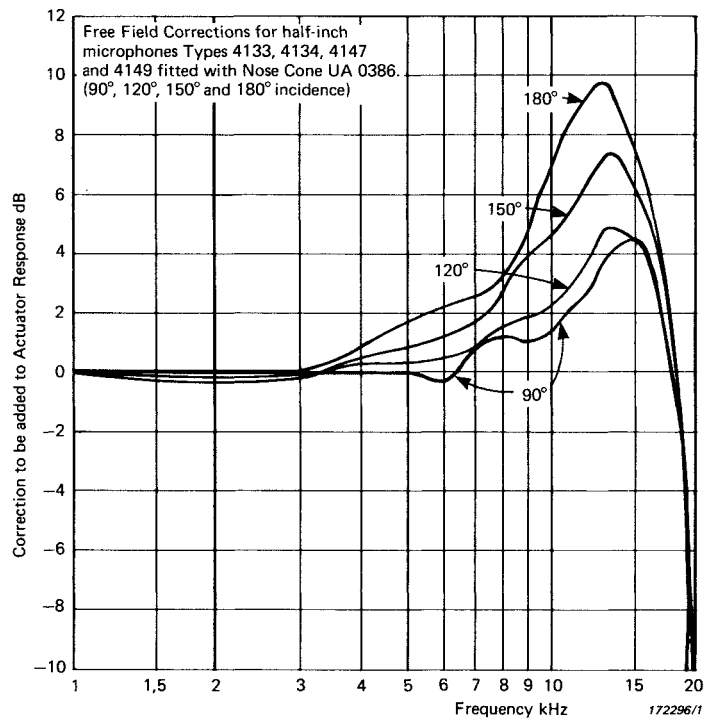
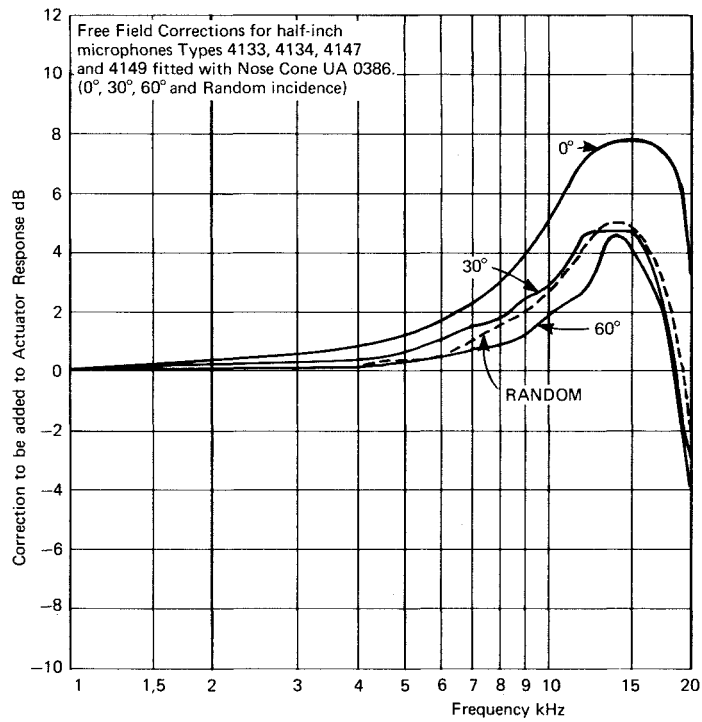

Fig.9.24. Free-field correction curves for half-inch microphones Types 4133, 4134, 4147 and 4149 fitted with Nose Cone UA 0386

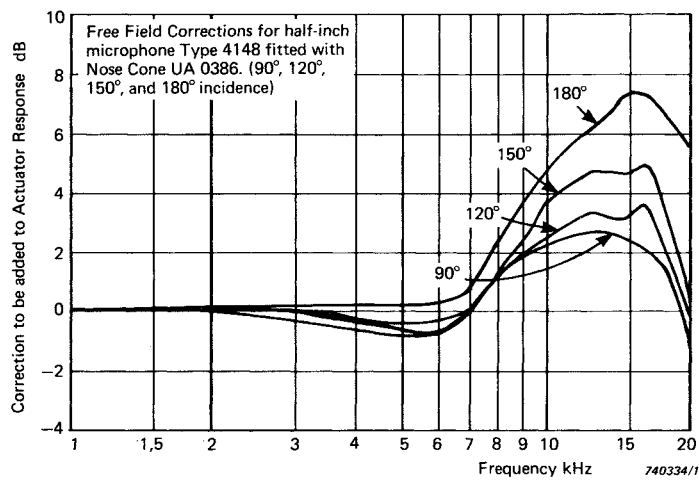
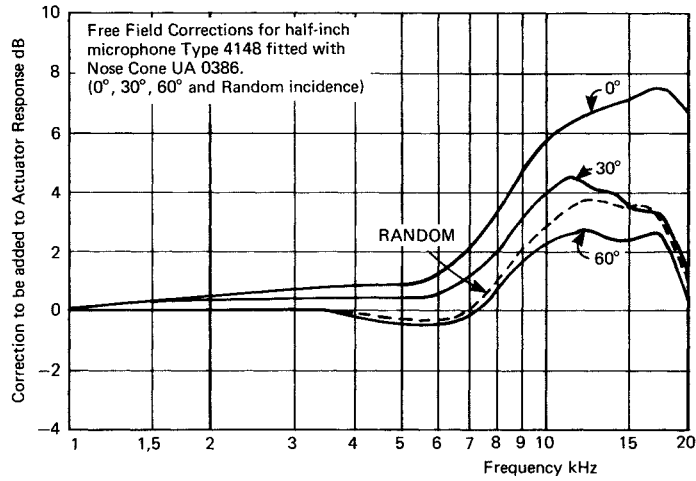

Fig.9.25. Free-field correction curves for half-inch microphone Type 4148 fitted with Nose Cone UA 0386

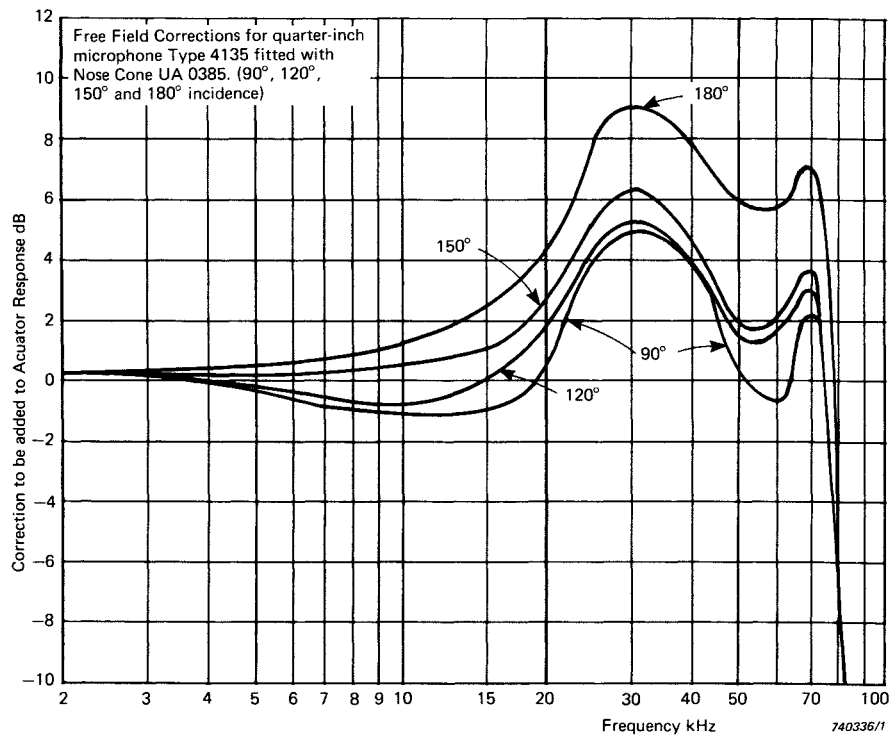
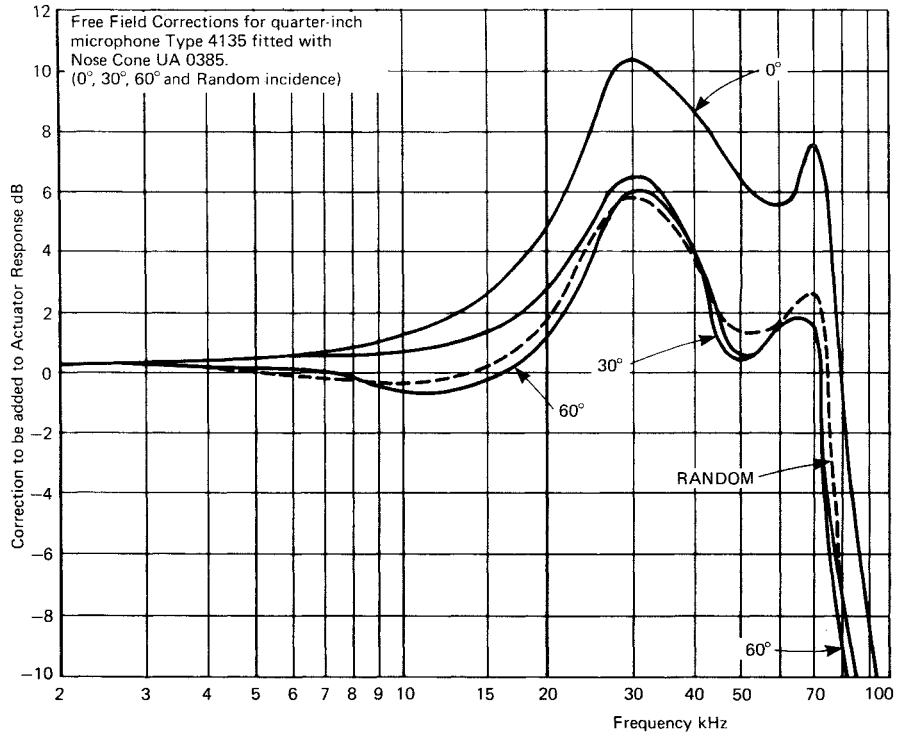

Fig.9.26. Free-field correction curves for quarter-inch microphone Type 4135 fitted with Nose Cone UA 0385

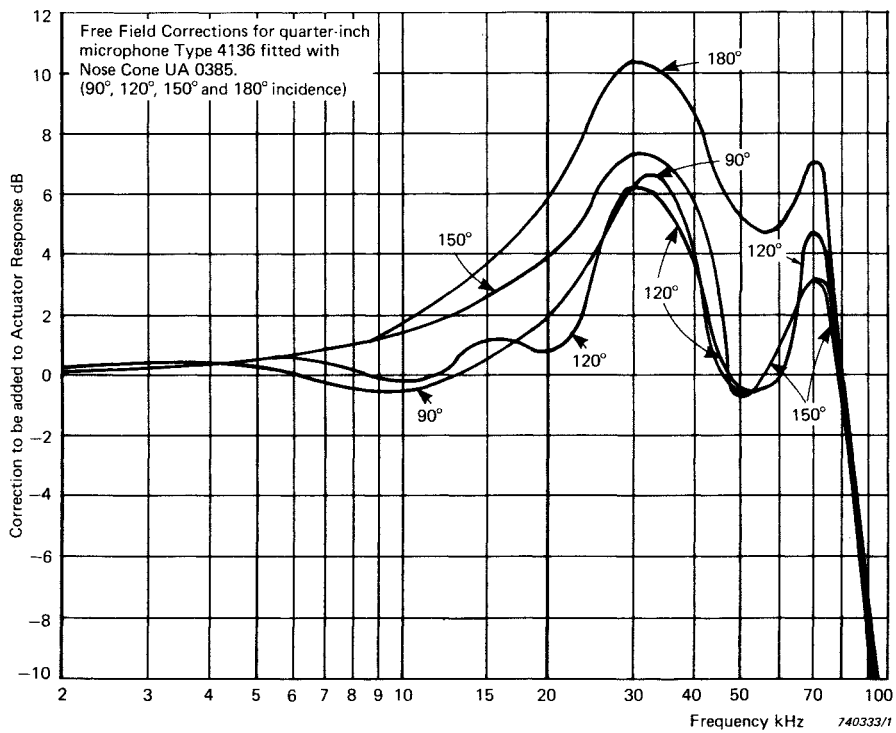
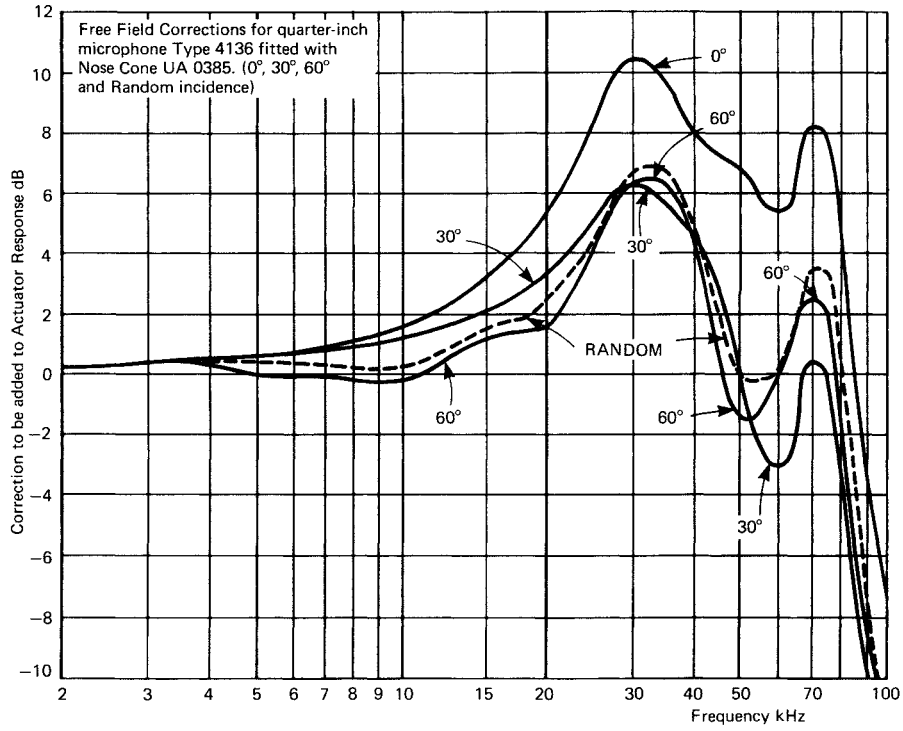

Fig.9.27. Free-field correction curves for quarter-inch microphone Type 4136 fitted with Nose Cone UA 0385

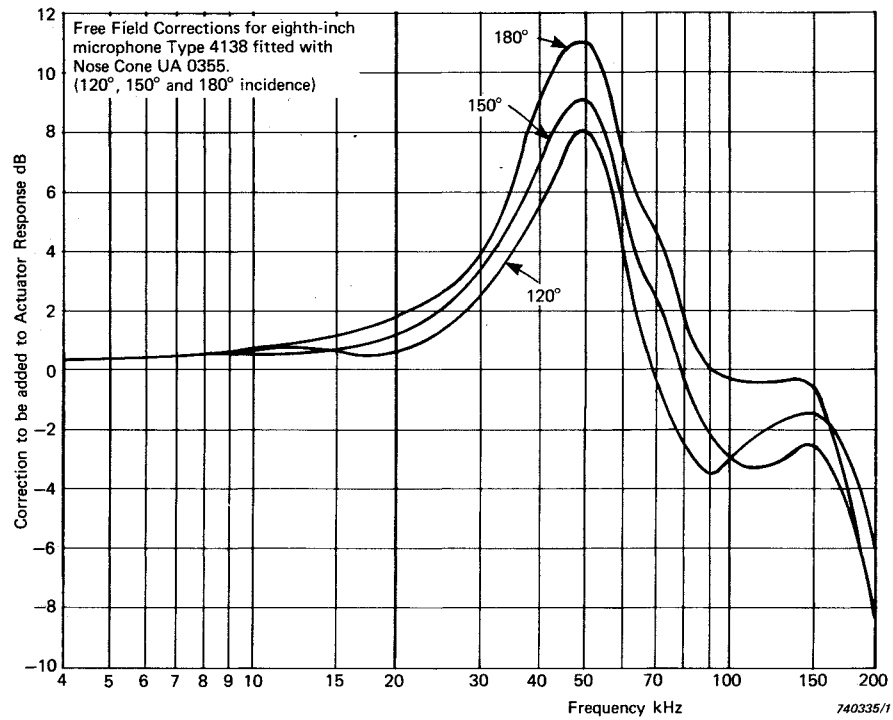
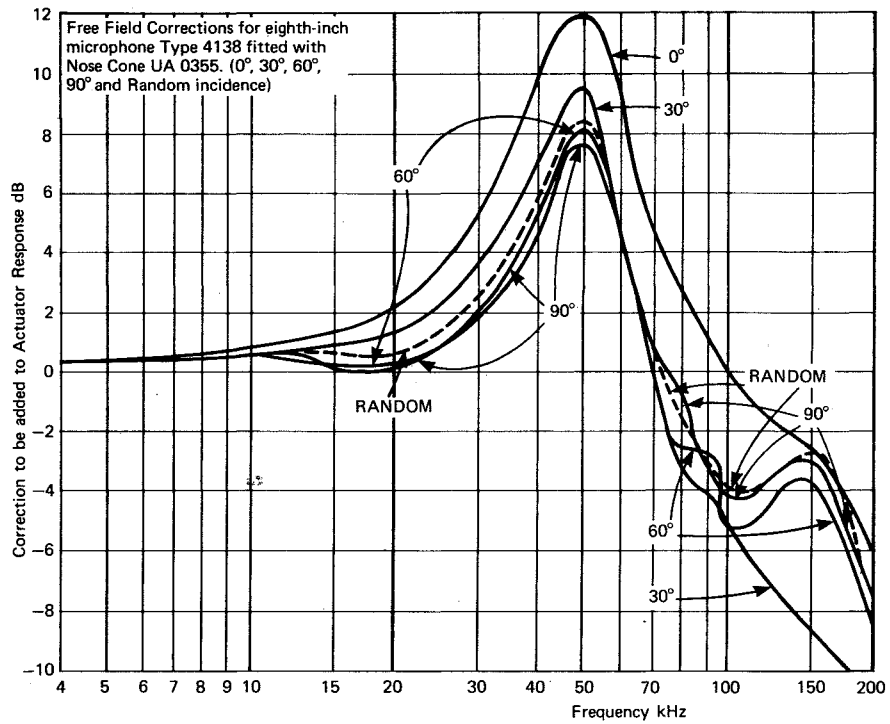

Fig.9.28. Free-field correction curves for eighth-inch microphone Type 4138 fitted with Nose Cone UA 0355

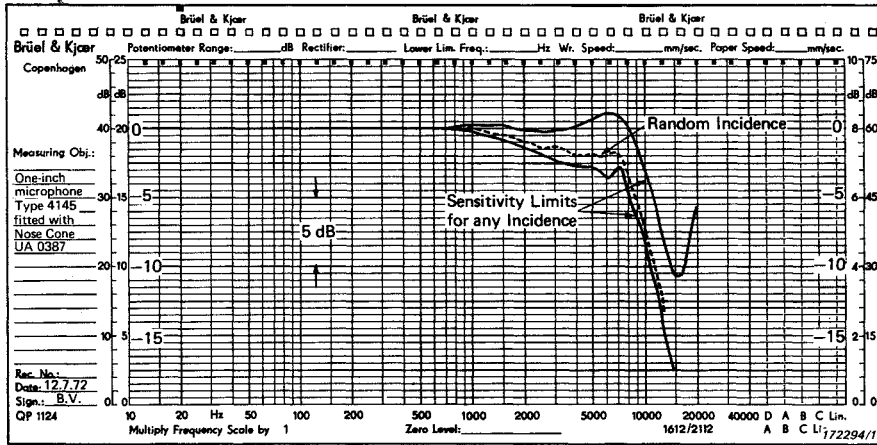

Fig.9.29. Sensitivity limits for any incidence for one-inch microphone Type 4145 fitted with Nose Cone UA 0387

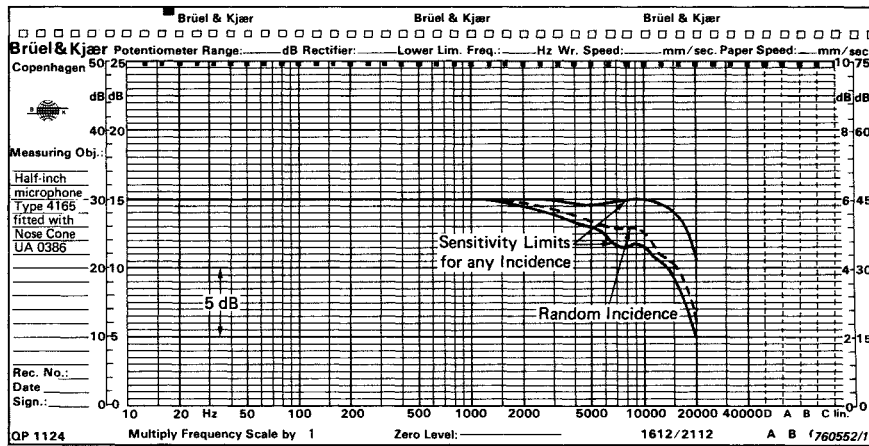

Fig.9.30. Sensitivity limits for any incidence for half-inch microphone Type 4165 fitted with Nose Cone UA 0386

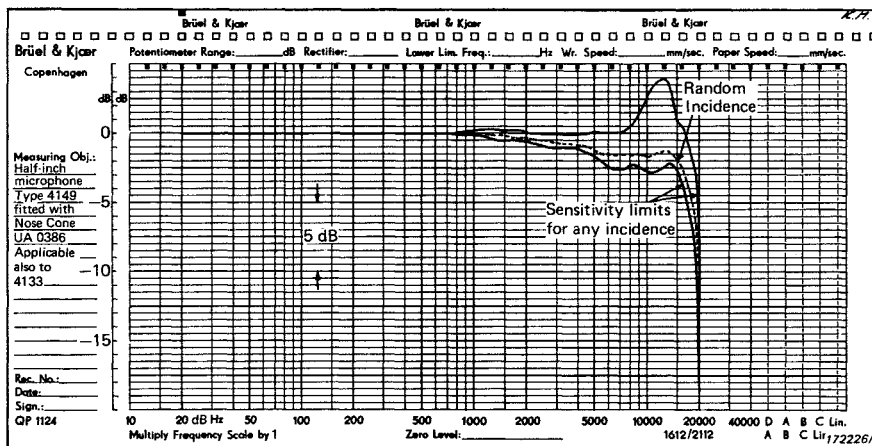

Fig. 9.31. Sensitivity limits for any incidence for half-inch microphone Types 4133 and 4149 fitted with Nose Cone UA 0386

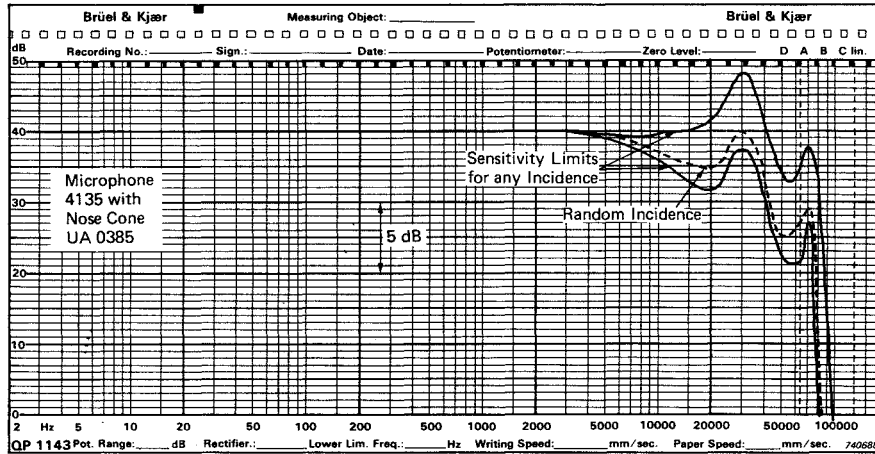

Fig.9.32. Sensitivity limits for any incidence for quarter-inch microphone Type fitted with Nose Cone UA 0385

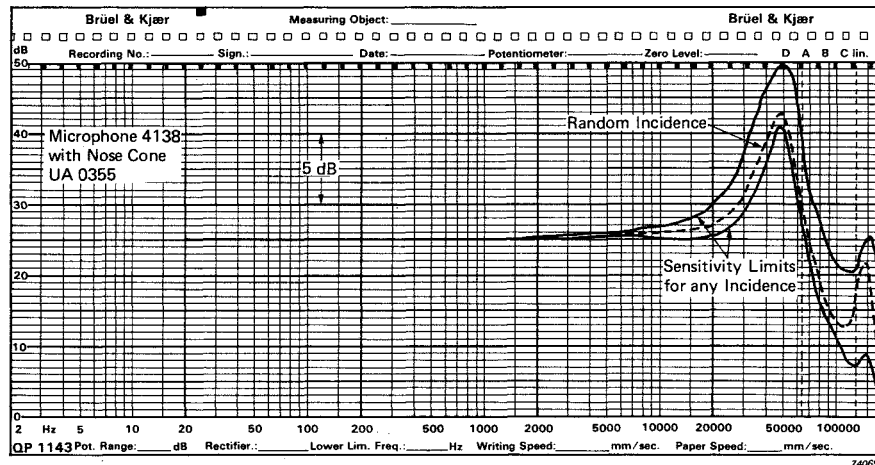

Fig.9.33. Sensitivity limits for any incidence for eighth-inch microphone Type 4138 fitted with Nose Cone UA 0355

9.5. TURBULENCE SCREEN UA 0436

Noise measurements in ducts can often be very difficult to perform accurately because of the presence of flow noise caused by turbulent pressure fluctuations which are produced within the duct and convected past the measuring microphone at the velocity of the airstream. The Turbulence Screen UA 0436, shown in Fig.9.34, is designed to minimize the problems associated with such measurements by rejecting the flow noise and passing the sound signal to the microphone. The Screen consists essentially of a tube with an axial slit covered with several layers of specially selected damping material to control the flow resistance of the slit. The Turbulence Screen may be used with a half-inch free field Condenser Microphone Type 4133, 4149 or 4165 and Microphone Preampifier Type 2619.

The turbulence induced noise when using the UA 0436 is approximately 16 dB better than that obtained using the half-inch Nose Cone UA 0386 in the frequency range 70 Hz to 1,5 kHz, as shown in Fig.9.35. The curves illustrated in Fig.9.35 were measured in a duct with particularly high levels of turbulence (air velocity = 20 m/s).

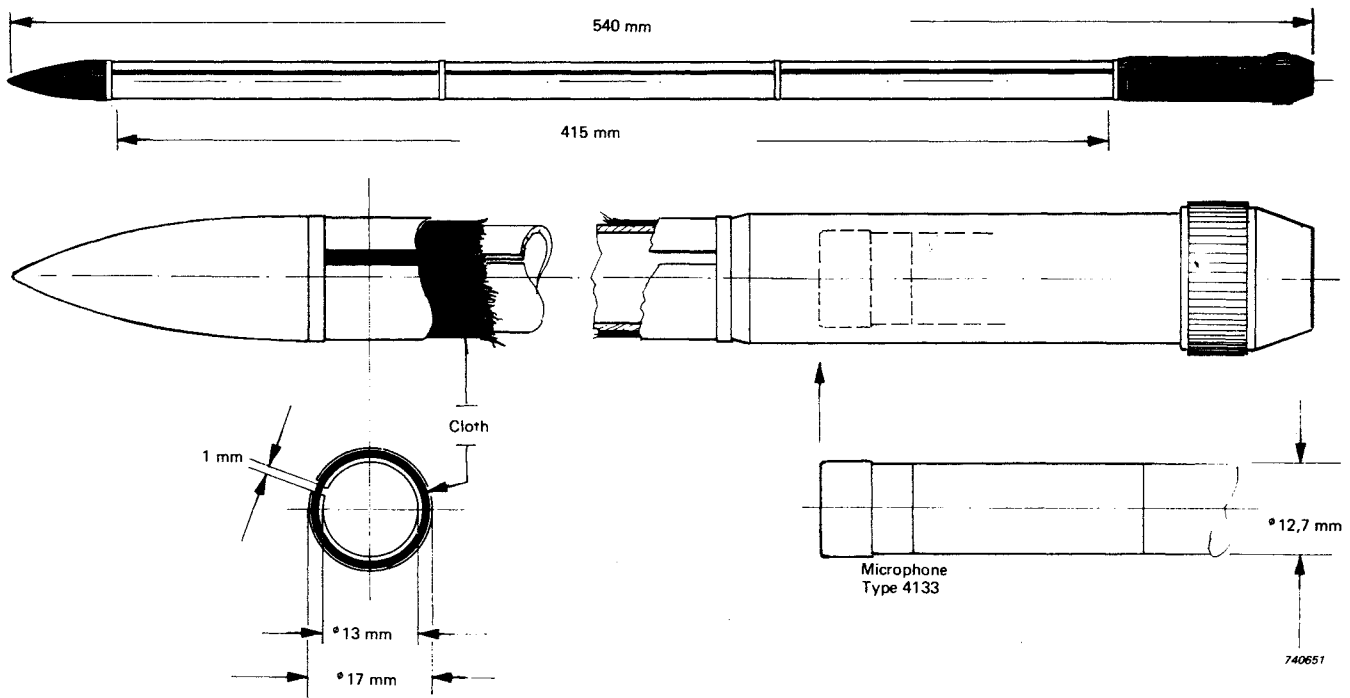

Fig.9.34. Turbulence Screen UA 0436

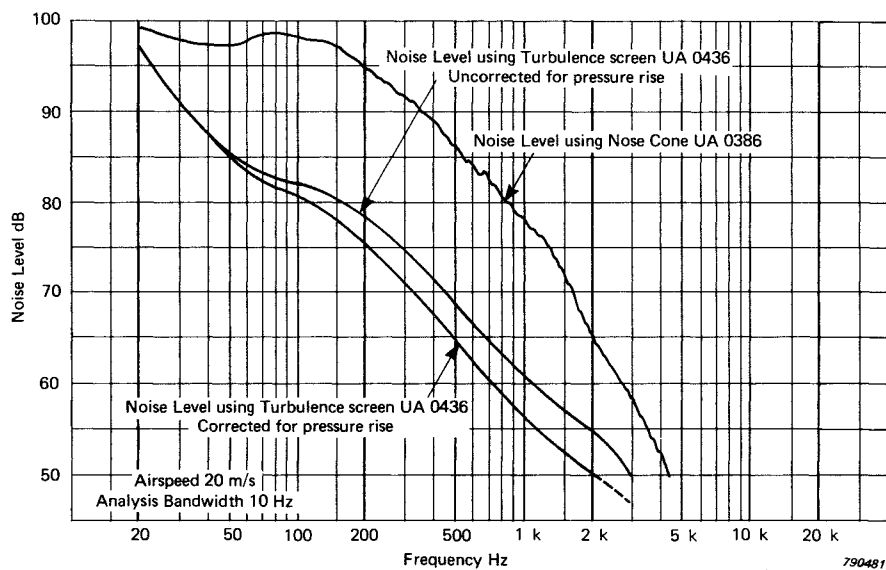

Fig.9.35. Comparison of turbulence induced noise levels using Turbulence Screen UA 0436 and half-inch Nose Cone UA 0386

Fig.9.36 shows the frequency response of half-inch microphone Type 4133 fitted with Turbulence Screen UA 0436 to sound incidence along its axis (0° and 180°). Both curves were measured in an anechoic chamber. The omnidirectivity of the Turbulence Screen is typically within ± 4 dB in the frequency range 20 Hz to 1 kHz.

Mounting the Turbulence Screen onto the microphone and preamplifier is illustrated in Fig.9.37. The procedure is as follows:

1. Slip locking ring A and teflon collet B onto the body of the half-inch Preamplifier P.

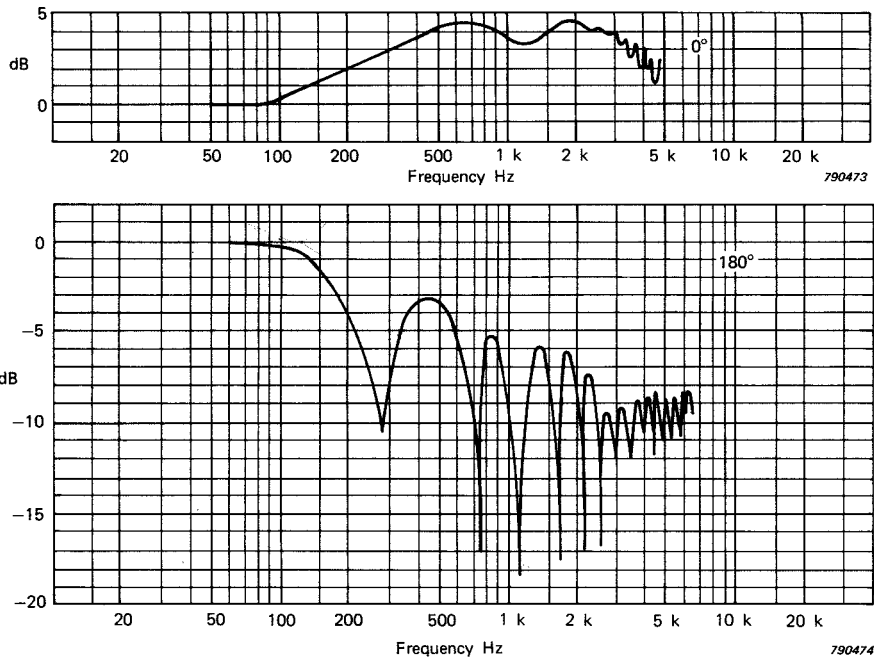

Fig.9.36. Frequency response of half-inch free-field Microphone Type 4133 fitted with Turbulence Screen UA 0436 (0° and 180° incidence)

2. Screw the Microphone 4133 onto the Preamplifier.
3. Slide the Microphone and Preamplifier into the Turbulence Screen as far as it will easily go.
4. Tighten the locking screw to secure the assembly.

Principal specifications of the Turbulence Screen with the 4133 Microphone are:

Frequency Response	20 Hz to 5 kHz (+ 5 dB) for incidence along axis of UA 0436
Turbulence Suppression	(70 Hz to 1,5 kHz): 16 dB better than with Nose Cone UA 0386 (see Fig.9.33)
Length	540 mm
Max. diameter	21 mm
Weight	200 g

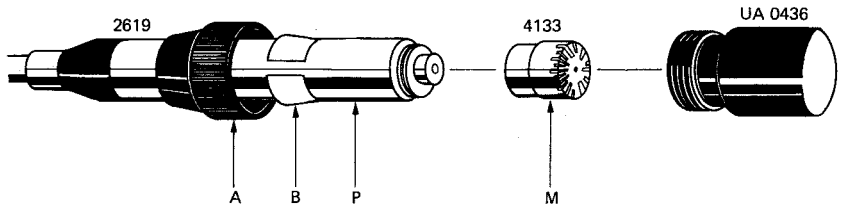

Fig.9.37. Assembly of Turbulence Screen UA 0436, Half-inch Microphone Type 4133 and Preamplifier Type 2619

9.6. RANDOM INCIDENCE CORRECTOR UA 0055

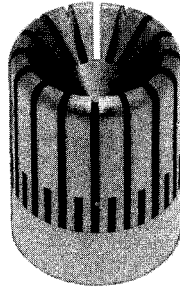

Fig.9.38. Random Incidence Corrector UA 0055

For measurements in diffuse sound fields where the direction of propagation of the incident sound is not well defined, the one-inch microphone in particular suffers inaccuracies because of the variation of its frequency response with angle of sound incidence above about 4 kHz. To minimize this problem, the Random Incidence Corrector UA 0055, shown in Fig.9.38, is available. It is designed to make the sensitivity of the one-inch microphone more omnidirectional. With this accessory fitted, the response at any incidence deviates by less than ± 3 dB from the random incidence response for frequencies up to 10 kHz.

Fig.9.39 shows the free-field corrections of the one-inch microphone Type 4145 fitted with the Random Incidence Corrector. Fig.9.40 shows the response of the one-inch free-field microphone fitted with this accessory. The UA 0055 is mainly intended for use with Type 4145. With the one-inch pressure microphone Type 4144, the UA 0055 will give less spreading in the directional characteristics at high frequencies, but the frequency response itself will be impaired and corrections will be required.

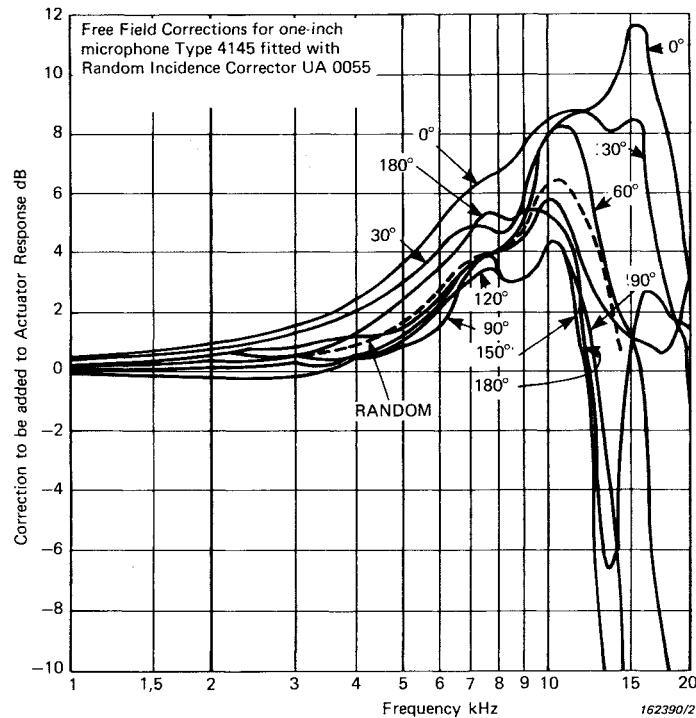

Fig. 9.39. Free-field correction curves for One-inch Microphone Type 4145 fitted with Random Incidence Corrector UA 0055

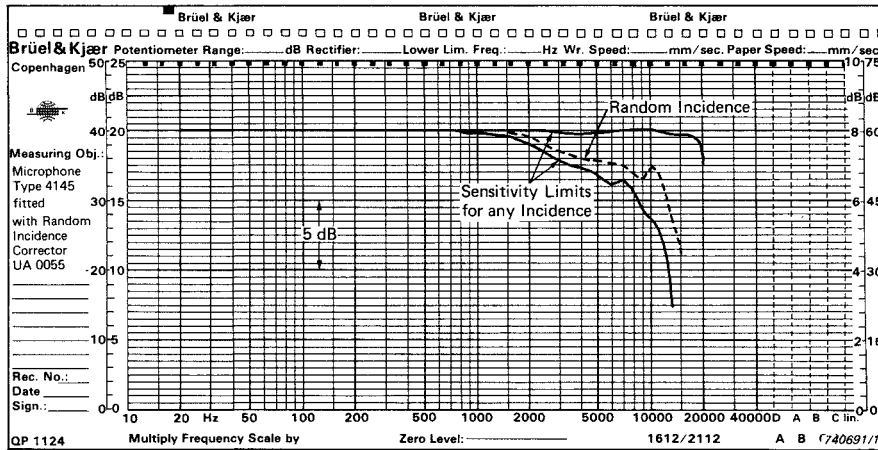

Fig.9.40. Sensitivity limits for any incidence for One-inch Microphone Type 4145 fitted with Random Incidence Corrector UA 0055

9.7. DEHUMIDIFIER UA 0308

A special unit for shorter-term outdoor measurements giving short-term protection from unfavourable weather is shown in Fig.9.41. It is based on one of the back vented half-inch Condenser Microphones Types 4148, 4149, 4165 or 4166 and the half-inch Dehumidifier UA 0308. All possible points of entry are blocked with either grease (if air leakage is also undesirable) or masking tape (where air leakage is desirable). The characteristics of the Windscreen UA 0237 are discussed in section 9.2.2. The function of the Dehumidifier is to ensure that only dry air reaches the interior cavity of the microphone thus preventing condensation. The assembly should be mounted horizontally in order that possible water droplets may run off the diaphragm.

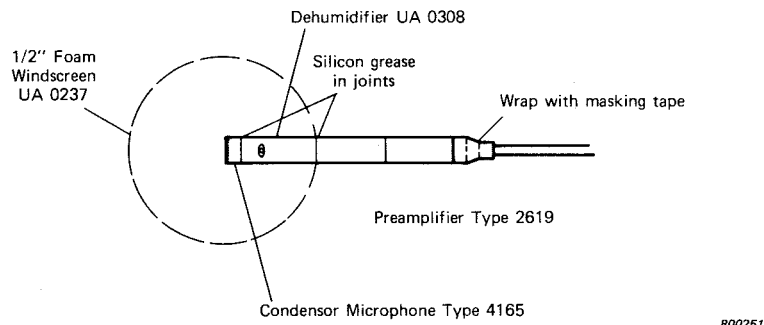

Fig.9.41. Rain proof assembly of Half-inch Microphone Type 4165, Dehumidifier UA 3008, Pre-amplifier Type 2619 and Windscreen UA 0237 for short-term outdoor measurements

9.8. PROBE MICROPHONES

9.8.1. Horn-Coupled Probe Microphone Type 4170

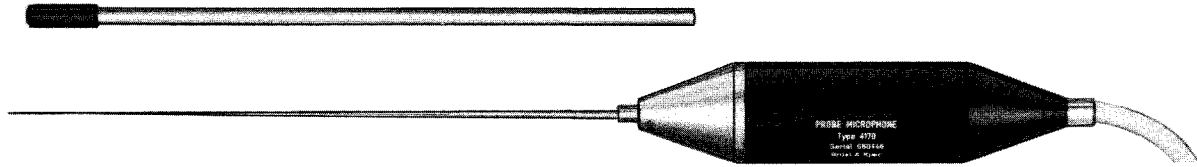

Fig.9.42. Horn Coupled Probe Microphone Type 4170

The Horn-Coupled Probe Microphone Type 4170, shown in Fig.9.42, is a high precision measuring microphone designed to cover a wide range of measurements where minimum disturbance of the sound field is important. The 4170 uses an acoustic exponential horn to couple a very thin probe tube to a half-inch condenser microphone and has a frequency response of +3; -1 dB in the frequency range 30 Hz to 8 kHz. The diameter of the nickel probe tip is 1,25 mm. Details of the theory and application of probe microphones and the characteristics of the 4170 are fully discussed in the Instruction Manual for Type 4170.

LITERATURE LIST

Many aspects of condenser microphones and their application to specific measurement situations have been discussed in various B & K application notes and the B & K Technical Review which is published quarterly. A selected list of some of the articles is given below.

- Rasmussen, G. "A New Condenser Microphone". B & K Technical Review, No.1, 1959
- Brüel, P.V., & Rasmussen, G. "Free Field Response of Condenser Microphones". B & K Technical Review, No.1 & 2, 1959
- Rasmussen, G. "Pressure Equalization of Condenser Microphones and Performance at Varying Altitudes". B & K Technical Review, No.1, 1960
- Rasmussen, G. "Miniature Pressure Microphones". B & K Technical Review, No.1, 1963
- Brüel, P.V. "The Accuracy of Condenser Microphone Calibration Methods. Part I". B & K Technical Review, No.4, 1964
- Brüel, P.V. "The Accuracy of Condenser Microphone Calibration Methods. Part II". B & K Technical Review, No.1, 1965
- Skøde, F. "Windscreening of Outdoor Microphones". B & K Technical Review, No.1, 1966
- Rasmussen, G. "The Free Field and Pressure Calibration of Condenser Microphones using Electrostatic Actuator". B & K Technical Review, No.2, 1969
- Frederiksen, E. "Long Term Stability of Condenser Microphones". B & K Technical Review, No.2, 1969

(The articles listed above have been collected together and are published in a booklet entitled "Selected Reprints from Technical Review — Measuring Microphones", September 1972.)

- Frederiksen, E. "Influence of Sunbeams striking the Diaphragms of Measuring Microphones". B & K Technical Review, No.1, 1974
- Frederiksen, E. "Condenser Microphones used as Sound Sources". B & K Technical Review, No.3, 1977

- Frederiksen, E. "Low Impedance Microphone Calibrator and its Advantages". B & K Technical Review, No.4, 1977
- Taniguchi, H.H., & Rasmussen, G. "Selection and Use of Microphones for Engine Aircraft Noise Measurements". B & K Technical Review, No.4, 1980
- Bernard, P. & Frederiksen, E. "High Pressure Measurements with the High Pressure Microphone Calibrator Type 4221". B & K Application Note, 17—231
- Bernard, P. "Microphone Intermodulation Distortion Measurements using the High Pressure Microphone Calibrator Type 4221". B & K Application Note, 083—80

International standards dealing with condenser microphones and microphone calibration:

International Electrotechnical Commission (IEC)
1, Rue de Varembe
1211 Geneva 20
Switzerland

- IEC 327 (1971): Precision method for pressure calibration of one-inch standard condenser microphones by the reciprocity technique
- IEC 402 (1972): Simplified method for pressure calibration of one-inch condenser microphones by the reciprocity technique
- IEC 486 (1974): Precision method for free-field calibration of one-inch standard condenser microphones by the reciprocity technique
- IEC 655 (1979): Values for the difference between free-field and pressure sensitivity levels for one-inch standard condenser microphones

For a list of national and international standards concerning acoustic measurements, see the B & K Brochure "National & International Standards and Recommendations". (Includes standards relevant to vibration & shock and luminance & contrast measurements.)

INDEX

Accessories	15, 113	Frequency response	16
Adaptors.....	15, 113	in He atmosphere	57
Ambient pressure, effect of variation in	87	effect of polarization voltage on.....	80
Back vented microphones.....	2, 40, 42	effect of temperature on.....	83
Calibration	95	effect of humidity on.....	92
Factory.....	97	Harmonic distortion.....	65
Laboratory	95	High frequency response	45
Field.....	34	High pressure calibration.....	97
Calibration chart.....	36	Humidity, effect of	92
Capacitance, microphone cartridge	16, 76	Insert voltage calibration	37
Care of microphone cartridges	33	Insulator.....	40
Construction, principle of	25, 39	Inherent Noise.....	64
Coupling capacitance.....	26	Ionized media, measurements in.....	29
Cut-off frequency, low frequency.....	27	K-factor.....	35
Dehumidifier	141	Laboratory calibration.....	95
Diaphragm.....	39	Leakage resistance of cartridge	82
Contamination of.....	33	Loaded sensitivity	44
Creep	83	Long term stability of microphones	83
Thermal noise	66	Lower limiting frequency (-3 dB point).....	98
Diffuse sound field.....	47	Magnetic fields, effect of	
Dimensions	41	on microphones.....	93
Microphone.....	41	on preamplifiers	112
Preamplifier	103, 104	Maximum sound pressure level exposure	66
Directivity	58	Measuring amplifier reference voltage.....	35
Driving point impedance	74	Mounting, cartridge	33
Dynamic range.....	64	Noise	
Electrostatic Actuators	95, 123	Preamplifier	106
Equalization vent.....	40, 42	Cartridge	64
Equivalent circuit diagrams	26	Turbulence induced	137
Equivalent air volume.....	73	Wind induced	117, 121, 126
Explosive media, measurements in	29	Nose Cones	125
Extension cables	15	Open circuit distortion limit (3%)	16, 64
Factory calibration.....	97	Open circuit sensitivity of microphones.....	16
Field calibration.....	34	Outdoor Microphone Unit Type 4921	13, 29
Free-field corrections.....	46	Permanent outdoor measurements.....	13, 29
microphone.....	46	Phase characteristics.....	70, 108
accessories.....	120, 123, 124, 129, 140		
Free-field response.....	46		
Free-field response microphones	55		
Frequency range.....	16		

Pistonphone Type 4220	34	Sound field, effect on preamplifier of.....	111
Polarization voltage.....	78	Sound Level Calibrator Type 4230	35
Power supplies.....	13, 32	Stray capacitance	26
Preamplifiers	17, 30, 102	Temperature coefficients	16
Pressure response	46	Temperature, effect of variation in.....	83
Pressure response microphones.....	55	Temperature range	16
Probe Microphone Type 4170.....	12, 142	Thermal noise	64
Pulse response	70	Tripod UA 0587.....	14
Rain Cover UA 0393.....	123	Turbulence induced noise.....	137
Random Incidence Corrector UA 0055.....	140	Turbulence Screen UA 0436.....	137
Random incidence measurements	29	Vibration, effect of	
Reciprocity calibration.....	95	on microphones.....	93
Sealing Kit UA 0240	13, 42	on preamplifiers	112
Side vented cartridge.....	40, 42	Windscreens	12, 115, 120
Solar radiation, effect of.....	94		

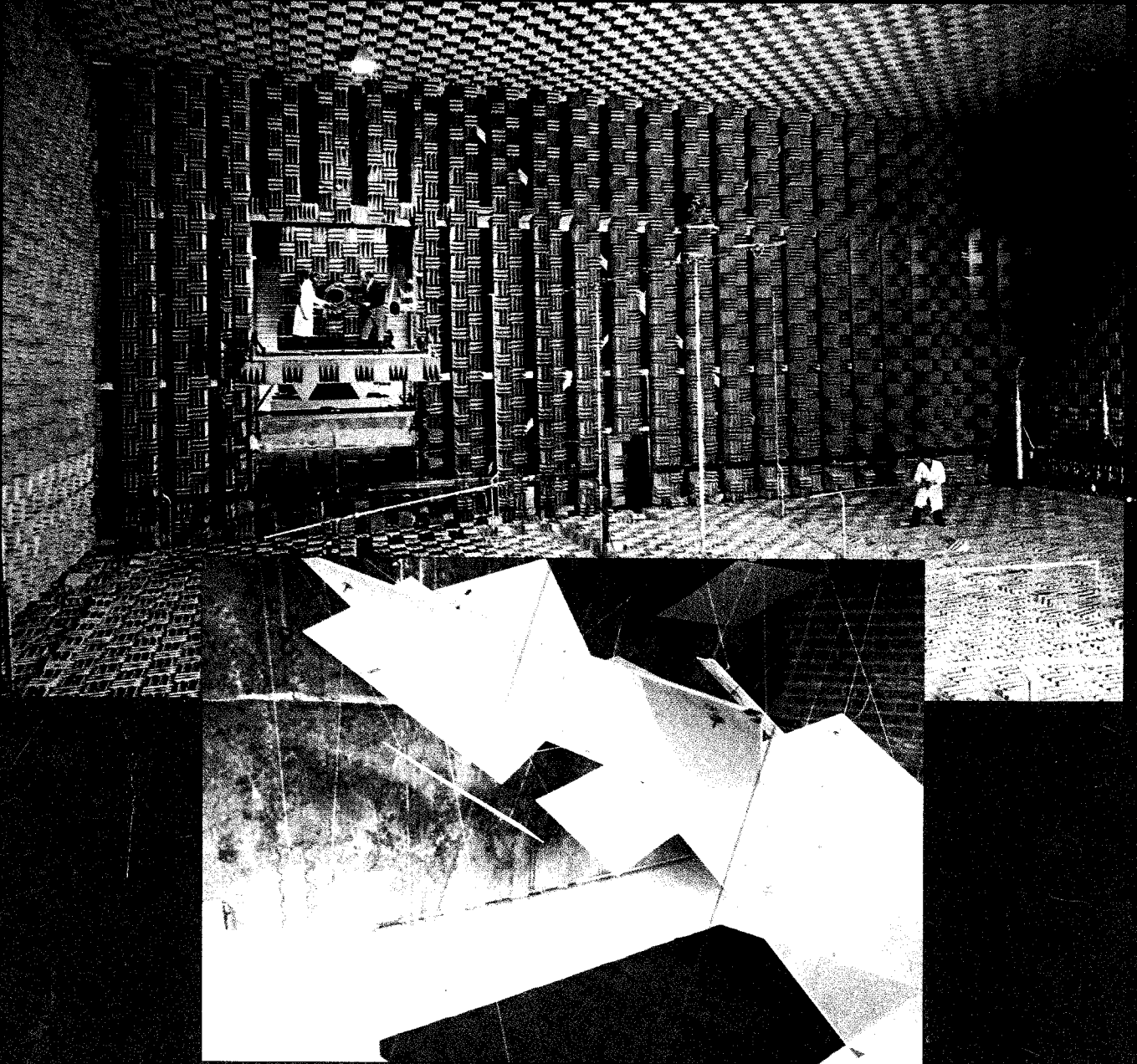

Brüel & Kjær

DK-2850 NÆRUM, DENMARK · Telephone: + 45 2 800500 · Telex: 37316 bruka dk